



**780.897.5869**  
BURKECALIBRATION.COM

# **Fisher L2 Liquid Level Controller Manual**

**Questions? Call us at 780-897-5869 or email [info@burkecalibration.com](mailto:info@burkecalibration.com)**

# Fisher™ L2 Liquid Level Controller

## Contents

Introduction .....	1
Scope of Manual .....	1
Description .....	3
Specifications .....	3
Education Services .....	3
Installation .....	4
Attaching Vertical Displacer .....	4
Attaching Horizontal Displacer .....	5
Attaching the Sensor to the Vessel .....	5
Pressure Connections .....	5
Vent .....	6
Changing Controller Action or Mode .....	6
Throttling and On/Off Controllers .....	6
Snap-Acting Controller .....	6
Span Adjustment .....	8
Preliminary Checks .....	8
Direct-Acting Throttling Controllers .....	9
Reverse-Acting Throttling Controllers .....	9
Direct-Acting On/Off and Snap-Acting Controllers .....	9
Reverse-Acting On/Off and Snap-Acting Controllers .....	9
Principle of Operation .....	10
Maintenance .....	11
Removing the Controller From the Sensor .....	11
Replacing the Sensor O-Rings .....	11
Disassembly .....	11
Assembly .....	13
Replacing the Controller Relay .....	13
Replacing the Controller Supply Filter .....	13

Figure 1. Fisher L2 Liquid Level Controller

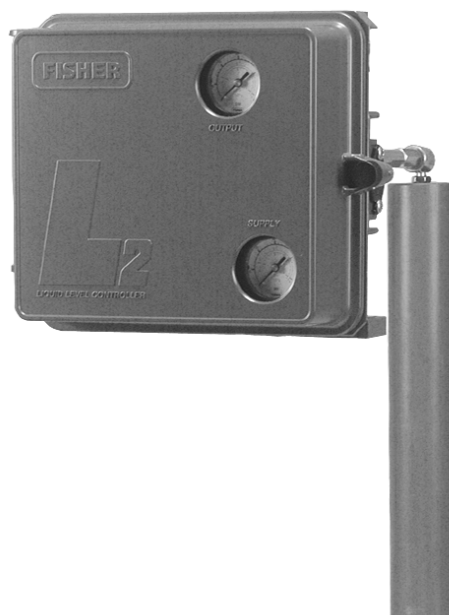

W8418-1

Related Documents .....	14
Parts Ordering .....	14
Parts Kits .....	14
Parts List .....	14
Controller .....	14
Sensor .....	16

## Introduction

### Scope of Manual

This instruction manual includes installation, adjustment, maintenance, and parts ordering information for the Fisher L2 liquid level controller.

Do not install, operate or maintain an L2 Liquid Level Controller without being fully trained and qualified in valve, actuator, and accessory installation, operation, and maintenance. To avoid personal injury or property damage, it is important to carefully read, understand, and follow all contents of this manual, including all safety cautions and warnings. If you have any questions about these instructions, contact your [Emerson sales office](#) before proceeding.

Table 1. Specifications

**Available Configurations**

The Fisher L2 series of controllers include the L2 and L2 Snap models

Controller: Snap-acting or throttling

Sensor: Displacer-type liquid level sensor for mounting to side of tank. Displacer travel is transmitted to controller by pivotal movement of displacer rod

**Input Signal**

Type: Liquid level or liquid-to-liquid interface

Level Change Required for Full Change in Output Signal in 1.0 Specific Gravity Liquid, with 1.4 Bar (20 Psig) Supply Pressure, Direct Action, and Standard 48 x 305 mm (1-7/8 X 12-Inch) Vertical Displacer with Standard Lever Arm Length:

Control Mode	Minimum Proportional Band Level Change, mm (Inches) <sup>(1)</sup>	Maximum Proportional Band Level Change, mm (Inches) <sup>(1)</sup>
Throttling	102 (4)	305 (12)
On/Off	127 (5)	305 (12)
Snap-acting	13 (0.5)	20 (0.8)

**Minimum Specific Gravity<sup>(2)</sup>**

Minimum specific gravity, or specific gravity differential for interface applications

Throttling Controllers: 0.4

On/Off Controllers: 0.45

Snap-Acting Controllers: 0.1

**Output Signal**

Pneumatic ■ on-off or ■ proportional pressure signal

Ranges:

Throttling: ■ 0.2 to 1.0 bar (3 to 15 psig) or ■ 0.4 to 2.0 bar (6 to 30 psig)

On/Off: 0 (off) or full supply pressure (on)

Action: Field-reversible between direct (increasing level increases output signal) and reverse (increasing level decreases output signal)

**Supply Pressure Requirements**

Throttling and On/Off Controller

Throttling: 1.4 bar for 0.2 to 1.0 bar output signal (20 psig for 3 to 15 psig output signal) and 2.4 bar for 0.4 to 2.0 bar output signal (35 psig for 6 to 30 psig output signal)

On/Off: Any desired pressure between 1.4 and 3.4 bar (20 and 50 psig).

Snap-Acting Controller: Any desired pressure between 1.4 and 5.2 bar (20 and 50 psig) direct, and 1.4 bar and 2.4 bar (20 and 35 psig) reverse

Do not use supply pressure below 1.4 bar (20 psig)

**Supply Medium**

Air or natural gas<sup>(3)</sup>

**Steady-State Air Consumption<sup>(4)</sup>**

Throttling Controller:  $\leq 0.03$  normal  $m^3/hr$  (1.0 scfh) at 1.4 bar (20 psig) supply pressure

Snap-Acting Controller:  $\leq 0.03$  normal  $m^3/hr$  (1.0 scfh) at 1.4 bar (20 psig) supply pressure or  $\leq 0.04$  normal  $m^3/hr$  (1.5 scfh) at 2.4 bar (35 psig) supply pressure in tripped condition; air consumption increases during trip

**Sensor to Vessel Connection**

■ 2 NPT threaded or ■ NPS 2 CL150 through 1500 slip-on flange connection<sup>(5)</sup>

**Controller Connections**

Supply: 1/4 NPT internal located on the bottom of the case

Output: 1/4 NPT internal located on the top of the case

Case Vent: 1/4 NPT internal with vent screen assembly located on the back of the case

**Standard Displacer Size**

48 x 305 mm, 541  $cm^3$  (1-7/8 x 12 inches, 33  $in^3$ )

**Maximum Displacer Insertion Length<sup>(6)</sup>**

Standard lever arm length plus one 6-inch extension, horizontal or vertical

**Displacer Material and Maximum Sensor Working Pressure<sup>(7)</sup>**

PVC Displacer: Consistent with CL1500 pressure temperature ratings per ASME B16.34 up to maximum pressure of 258 bar (3750 psig)  
For PED (97/23/EC) maximum pressure limited to 200 bar (2900 psig)

S31603 SST Displacer: CL600 pressure temperature ratings per ASME B16.34 up to maximum pressure of 99.3 bar (1440 psig)

Note: For slip-on flange connection, maximum sensor working pressure must be consistent with the flange ratings

-Continued-

Table 1. Specifications (continued)

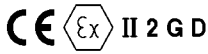
<p><b>Displacer Material and Sensor Temperature Limits<sup>(7)</sup></b>                  PVC Displacer -29 to 79°C (-20 to 175°F)                  S31603 SST Displacer: -40 to 204°C (-40 to 400°F)</p> <p><b>Operative Ambient Temperature Limits<sup>(7)</sup></b>                  Controller: -29 to 71°C (-20 to 160°F)</p> <p><b>Standard Supply, and Output Pressure Gauge Indications</b>                  Triple scale gauges in 0 to 60 psig/0 to 0.4 MPa/0 to 4.0 bar</p> <p><b>Hazardous Area Classification</b>                  Complies with the requirements of ATEX Group II Category 2 Gas and Dust</p> <p> EX h IIC Tx Gb EX h IIIC Tx Db</p>	<p>Maximum surface temperature (Tx) depends on operating conditions</p> <p><b>Gas:</b> T6 <b>Dust:</b> T71</p> <p><b>Declaration of SEP</b></p> <p>Fisher Controls International LLC declares this product to be in compliance with Article 4 paragraph 3 of the PED Directive 2014/68/EU. It was designed and manufactured in accordance with Sound Engineering Practice (SEP) and cannot bear the CE marking related to PED compliance.</p> <p>However, the product <i>may</i> bear the CE marking to indicate compliance with <i>other</i> applicable European Community Directives.</p>
---	---

NOTE: Specialized instrument terms are defined in ISA Standard 51.1 - Process Instrument Terminology.  
 1. Any deviation from the standard construction described in the input signal specification above requires special displacer sizing considerations. Contact your [Emerson sales office](#) for information.  
 2. Depends on float rod/displacer orientation and length. Contact your Emerson sales office before proceeding for further information.  
 3. This product can be used with natural gas as the supply medium.  
 4. Normal m<sup>3</sup>/hr—Normal cubic meters per hour (0°C and 1.01325 bar, absolute) Scfh—Standard cubic feet per hour (60°F and 14.7 psia).  
 5. Converting from a threaded NPT connection to a flange connection is to be done by the end-user. Refer to Converting a Threaded NPT Connection to a Flange Connection instruction Manual Supplement ([D103277X012](#)), available at [www.Fisher.com](http://www.Fisher.com) or from your Emerson sales office.  
 6. Standard lever arm length.  
 7. The pressure and temperature limits in this document and any applicable code limitations should not be exceeded.

## Description

The rugged L2 liquid level controllers use a displacer type sensor (see figure 1) to detect liquid level or the interface of two liquids of different specific gravities.

These controllers use a single four-mode relay to provide the applicable control and action. The device delivers a pneumatic output signal to a control/dump valve.

Unless otherwise noted, all NACE references are to NACE MR0175-2002.

## Specifications

Specifications for the controller and sensor are listed in table 1.

## Educational Services

For information on available courses for L2 Liquid Level Controllers, as well as a variety of other products, contact:

Emerson Automation Solutions  
 Educational Services - Registration  
 Phone: 1-641-754-3771 or 1-800-338-8158  
 E-mail: [education@emerson.com](mailto:education@emerson.com)  
[emerson.com/fishervalvetraining](http://emerson.com/fishervalvetraining)

## Installation

### **⚠ WARNING**

Always wear protective clothing, gloves, and eyewear when performing any installation operations to avoid personal injury.

To avoid personal injury or property damage caused by the sudden release of process fluid, be certain the service conditions do not exceed the sensor pressure limits. Use pressure-limiting or pressure-relieving devices to prevent service conditions from exceeding these limits.

Personal injury or property damage may result from fire or explosion if natural gas is used as the supply medium and appropriate preventive measures are not taken. Preventive measures may include, but are not limited to, one or more of the following: Remote venting of the unit, re-evaluating the hazardous area classification, ensuring adequate ventilation, and the removal of any ignition sources. For information on remote venting of this controller, refer to page 6.

Check with your process or safety engineer for any additional measures that must be taken to protect against process media.

If installing this into an existing application, also refer to the WARNING at the beginning of the Maintenance section of this instruction manual.

### **CAUTION**

Do not use sealing tape on pneumatic connections. This instrument contains small passages that may become obstructed by detached sealing tape. Thread sealant paste should be used to seal and lubricate pneumatic threaded connections.

### **CAUTION**

If the L2 level controller is installed on a vessel that is to be shipped to a different location (e.g. skid mounted units), remove the displacer and displacer rod extensions before shipment. Failure to do so could result in damage to the displacer rod due to vibration and impact loading during shipment. After the vessel is installed at its final location, reassemble the displacer and displacer rod extension.

1. Be sure there are no obstructions inside the tank that will interfere with displacer installation or operation.
2. Provide the appropriate connection in the tank wall to match the sensor connection. Locate the tank wall connection such that the displacer will be at the desired control level.

## Attaching a Vertical Displacer

Refer to figure 7 for part locations.

1. Thread jam nut (key 68) all the way onto the threaded portion of the universal joint assembly (key 69).
2. Thread the displacer (key 81) all the way onto the threaded portion of the universal joint assembly.
3. Tighten the jam nut (key 63) against the displacer (key 81).

## Attaching a Horizontal Displacer

Refer to figure 7 for part locations.

1. Thread the displacer (key 81) all the way onto the displacer rod (key 64) or extension (key 82).
2. Tighten the jam nut (key 63) against the displacer (key 81).

## Attaching the Sensor to the Vessel

Insert the displacer end of the controller-sensor assembly into the tank connection, and screw the sensor threads into the tank connection. Tighten sufficiently to seal the threads. If necessary, loosen or tighten slightly to obtain the orientation shown in figure 2. Make sure that the controller case is level.

### CAUTION

Do not pick up the controller/sensor by lifting the displacer rod (key 64). This action could place excessive stress on the displacer rod and cause the unit to malfunction.

Figure 2. Sensor Orientation

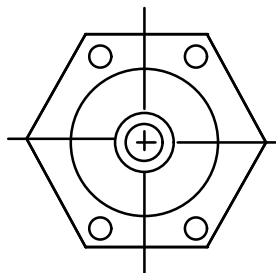

CORRECT CONTROLLER MOUNTING  
HOLE ORIENTATION WHEN MOUNTED ON VESSEL

A6639

## Pressure Connections

### ⚠ WARNING

Personal injury or property damage may occur from an uncontrolled process if the supply medium is not clean, dry, oil-free air, or non-corrosive gas. While use and regular maintenance of a filter that removes particles larger than 40 micrometers in diameter will suffice in most applications, check with an Emerson field office and industry instrument air quality standards for use with corrosive air or if you are unsure about the proper amount or method of air filtration or filter maintenance.

### CAUTION

Do not use sealing tape on pneumatic connections. This instrument contains small passages that may become obstructed by detached sealing tape. Thread sealant paste should be used to seal and lubricate pneumatic threaded connections.

1. Provide a source of clean, dry air that meets the requirements of ISA Standard 7.0.01 as the operating medium. Refer to table 1 to determine supply pressure.
2. Connect the supply pressure to the 1/4 NPT internal connection on the bottom of the controller case.
3. Connect the output signal line to the equipment being operated and to the 1/4 NPT output connection on the top of the controller case.

## Vent

### **⚠ WARNING**

**If a flammable or hazardous gas is to be used as the supply pressure medium, personal injury or property damage could result from fire or explosion of accumulated gas or from contact with hazardous gas. The controller/actuator assembly does not form a gas-tight seal, and when the assembly is enclosed, a remote vent line, adequate ventilation, and necessary safety measures should be used. However, a remote vent pipe alone cannot be relied upon to remove all hazardous gas. Vent line piping should comply with local and regional codes and should be as short as possible with adequate inside diameter and few bends to reduce case pressure buildup.**

The vent opening or the end of the remote vent pipe, if one is required, must be protected against the entrance of all foreign matter that could plug the vent. Use 13 mm (1/2-inch) diameter pipe for the remote vent pipe. Check the vent periodically to be certain it is free of any obstructions.

## Changing Controller Action or Mode

### **⚠ WARNING**

**To avoid personal injury caused by a sudden release of pressure, shut off the supply pressure and bleed pressure from the supply lines before performing any procedure in this section.**

## Throttling and On/Off Controller

The action of a throttling and on/off controller may be changed between either direct or reverse, and the control mode may be changed between either on/off or throttling.

Refer to figure 3. Loosen the four switch retention screws on the relay. Move the switches to the control action and control mode required by the application. Tighten the four switch retention screws.

## Snap-Acting Controller

The action of a snap-acting controller may be changed between either direct or reverse. The control mode is always snap acting.

Refer to figure 4. Loosen the four switch retention screws on the relay. Move the switches to the control action required by the application. Tighten the four switch retention screws.

Figure 3. Fisher L2 Throttling and On/Off Controller Switch Positions for Changing Action and Control Mode

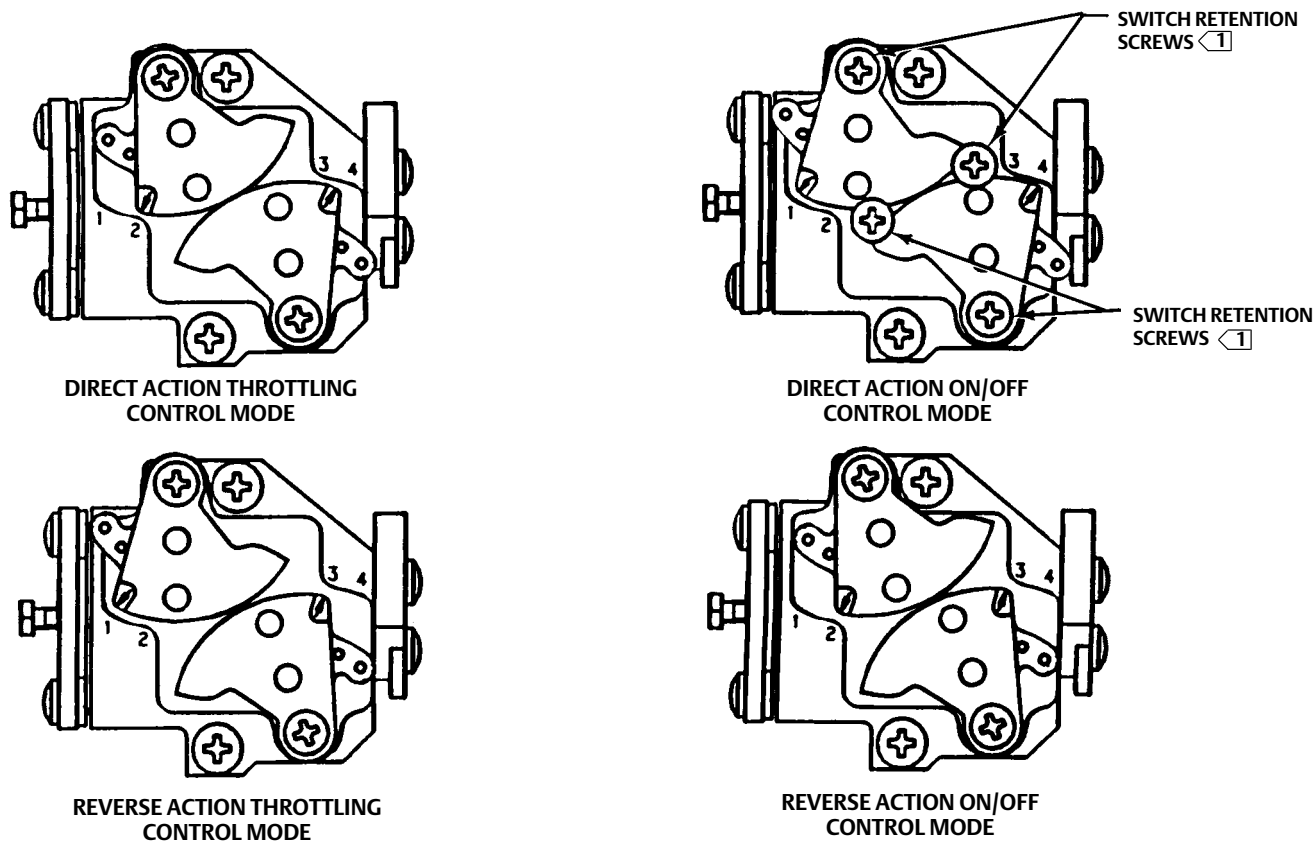

NOTE:  
<1> ALL FOUR SWITCH RETENTION SCREWS SHOWN ONLY ON THIS VIEW. OTHER VIEWS SHOW ONLY TWO SWITCH RETENTION SCREWS IN ORDER TO ILLUSTRATE THE SWITCH CONFIGURATION.

B2339

Figure 4. Fisher L2 Snap-Acting Controller Switch Positions for Changing Action

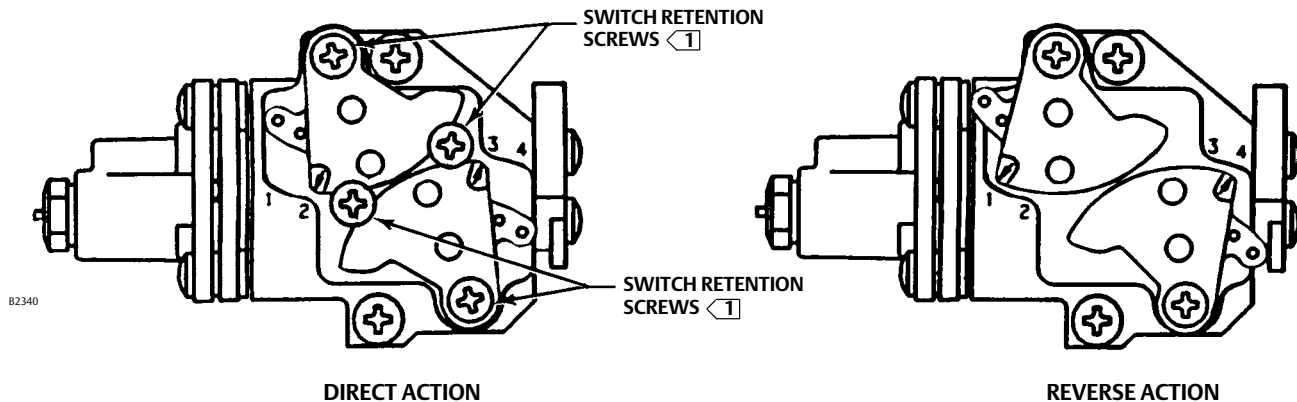

NOTE:  
<1> ALL FOUR SWITCH RETENTION SCREWS SHOWN ONLY ON THIS VIEW. OTHER VIEWS SHOW ONLY TWO SWITCH RETENTION SCREWS IN ORDER TO ILLUSTRATE THE SWITCH CONFIGURATION.

B2340



## Span Adjustment

Except where indicated, key numbers referenced in the following procedures are shown in figure 8. The span levers and other proportional band information are shown in figure 5.

Figure 5. Proportional Band Adjustments

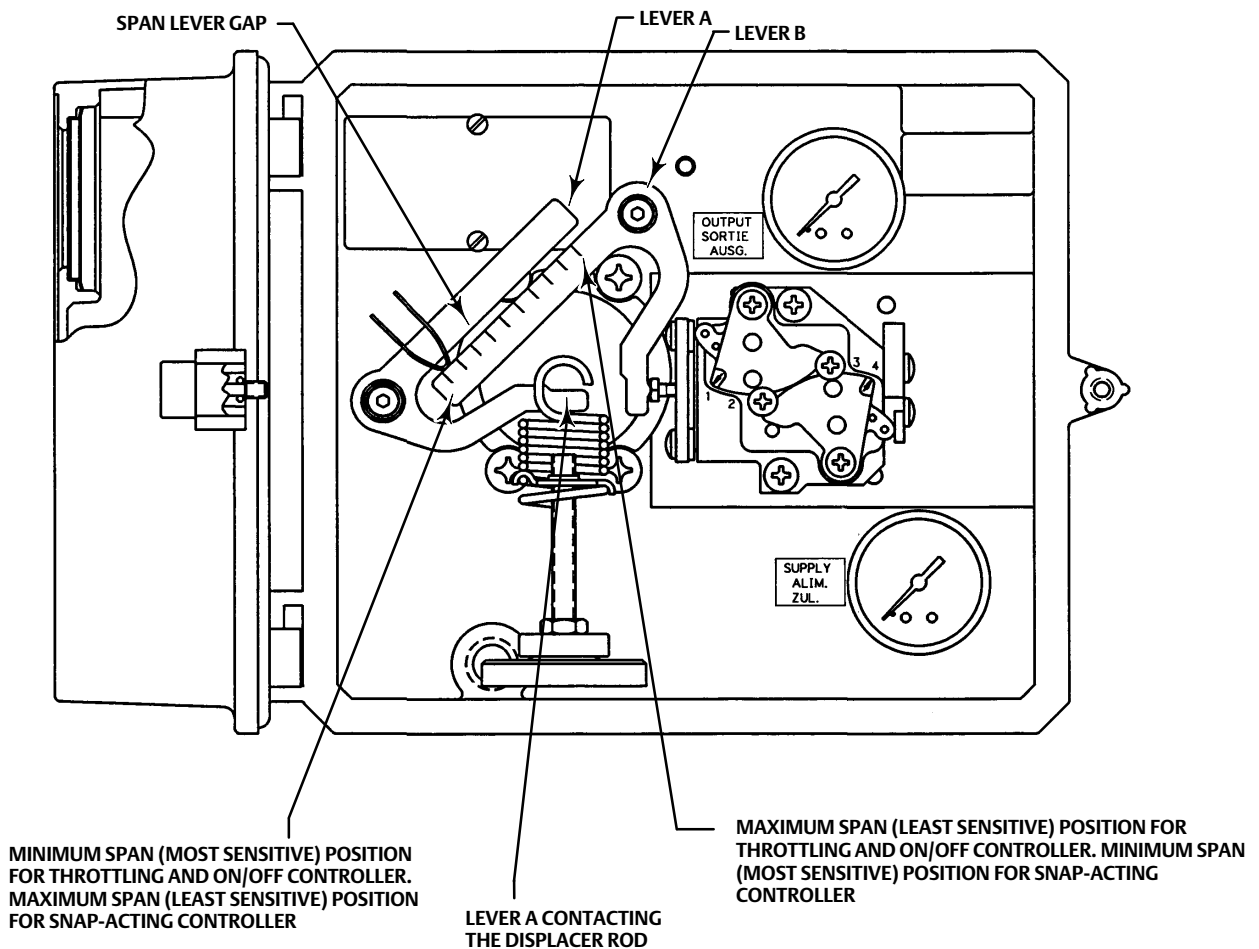

CB0137-2  
E0787

## Preliminary Checks

1. Check the supply pressure gauge (key 10) to be certain that the supply pressure is at the desired value. Adjust the supply pressure as required.
2. Adjust the displacer rod to the horizontal position with the spring adjustment (key 4).
3. Bounce the end of the displacer rod (key 64, figure 7) up and down to check that the sensor is operating freely.
4. Place the span adjuster (key 9) at the desired position (see figure 5).

5. Check figures 3 and 4 for correct control action and control mode.
6. Adjust the relay adjustment screw (key 49, throttling controller) or the valve assembly (key 51, snap-acting controller) so that the gap between the span levers (see figure 5) is equal when lever A is contacting the displacer rod.

## Direct-Acting Throttling Controllers

1. Make certain the Preliminary Checks procedure at the start of this section has been completed.
2. Lower the liquid level so that it is below the bottom of the displacer or at the lowest desired operating point on the displacer. For interface applications, completely cover the displacer with the fluid with the lower specific gravity. The heavier fluid should be below the bottom of the displacer or at the lowest desired operating point on the displacer.
3. Adjust the spring adjustment (key 4) until the output pressure is 1 to 2 psig for a 3 to 15 psig output range, or 2 to 4 psig for a 6 to 30 psig output range.

## Reverse-Acting Throttling Controllers

1. Make certain the Preliminary Checks procedure at the start of this section has been completed.
2. Lower the liquid level so that it is below the bottom of the displacer or at the lowest desired operating point on the displacer. For interface applications, completely cover the displacer with the fluid with the lower specific gravity. The heavier fluid should be below the bottom of the displacer or at the lowest desired operating point on the displacer.
3. Adjust the spring adjustment (key 4) until the output is 16 to 17 psig for a 3 to 15 psig output range, or 31 to 34 psig for a 6 to 30 psig output range.

## Direct-Acting On/Off and Snap-Acting Controllers

1. Make certain the Preliminary Checks procedure at the start of this section has been completed.
2. Lower the liquid level so that it is below the bottom of the displacer or at the lowest desired operating point on the displacer. For interface applications, completely cover the displacer with the fluid with the lower specific gravity. The heavier fluid should be below the bottom of the displacer or at the lowest desired operating point on the displacer.
3. Adjust the spring adjustment (key 4) until the output pressure is at full supply pressure.
4. Readjust the spring adjustment (key 4) until the output pressure goes to zero psig.

## Reverse-Acting On/Off and Snap-Acting Controllers

1. Make certain the Preliminary Checks procedure at the start of this section has been completed.
2. Lower the liquid level so that it is below the bottom of the displacer or at the lowest desired operating point on the displacer. For interface applications, completely cover the displacer with the fluid with the lower specific gravity. The heavier fluid should be below the bottom of the displacer or at the lowest desired operating point on the displacer.
3. Adjust the spring adjustment (key 4) until the output pressure goes to zero psig.
4. Readjust the spring adjustment (key 4) until the output pressure goes to full supply pressure.

## Principle of Operation

The operation of L2 controllers in combination with the sensor is based on Archimedes Principle, which states that a body immersed in a liquid will be buoyed up by a force equal to the weight of the liquid displaced. The buoyant force and resultant movement of the displacer in the liquid is transmitted to the controller which delivers a pneumatic signal to a control valve.

Figure 6 shows a simple schematic of the controller and sensor. In its normal position, the counterclockwise moment due to the weight of the displacer about pivot point O is balanced by the clockwise zero spring moment and the counterclockwise relay zero force moment applied through lever A to the displacer rod. The weight of the displacer decreases when the liquid level increases and the subsequent buoyant force increases causing a force imbalance between the zero spring, relay, and displacer forces. This force imbalance is transmitted to the relay by levers A and B. The relay compensates for the force imbalance by converting it to a pressure output to a control valve and bringing the forces back into equilibrium.

Figure 6. Operational Schematic

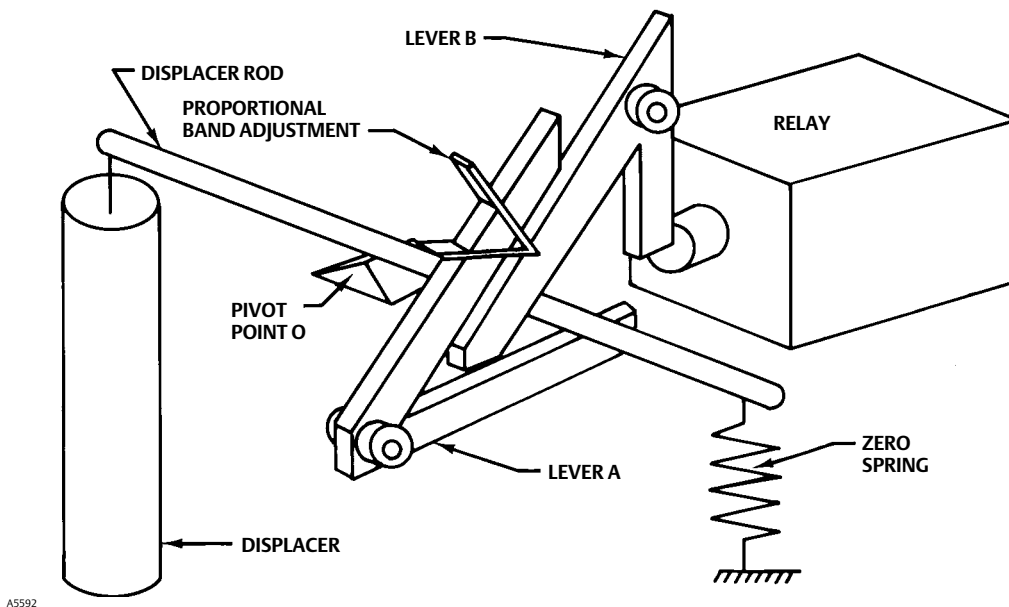

For throttling control, the relay pressure output will be proportional to the buoyant force. For on/off control, the relay pressure output will be either zero or equal to the supply pressure over the range of liquid level change. The liquid level change required to fully operate the relay is adjusted by sliding the proportional band adjustment along lever A to vary the lever ratio between levers A and B.

With reverse-acting proportional control, the principle of operation remains the same as that for direct action; however, the controller delivers an increasing pneumatic signal to the control valve when the liquid level falls.

## Maintenance

Parts are subject to normal wear and must be inspected periodically and replaced as necessary. The frequency of parts inspection and replacement depends upon the severity of service conditions. When inspection or repairs are required, disassemble only those parts necessary to accomplish the task.

### **⚠ WARNING**

Always wear protective clothing, gloves, and eyewear when performing any maintenance operations to avoid personal injury.

To avoid personal injury or property damage caused by the release of pressure or process fluid, observe the following before starting maintenance:

- Personal injury or property damage may result from fire or explosion if natural gas is used as the supply medium and appropriate preventive measures are not taken. Preventive measures may include, but are not limited to, one or more of the following: Remote venting of the unit, re-evaluating the hazardous area classification, ensuring adequate ventilation, and the removal of any ignition sources. For information on remote venting of this controller, refer to page 6.
- Provide some temporary means of control for the process before taking the controller out of service.
- Provide a means of containing the process fluid before removing any measurement devices from the process.
- Vent any trapped process pressure.
- Check with your process or safety engineer for any additional measures that must be taken to protect against process media.

## Removing the Controller From the Sensor

1. Disconnect the supply and output pressure lines.
2. Slide the hook end of the zero spring (key 5, figure 8) over and off the controller end of the displacer rod (key 64, figure 7).
3. Remove the four controller mounting screws (key 11, figure 8), and pull the controller straight away from the sensor.

## Replacing the Sensor O-Rings

Refer to figure 7 for key number locations unless otherwise indicated.

### Disassembly

1. Remove the controller from the sensor by following the procedure outlined in the previous section.
2. Remove the sensor from the tank.
3. Unscrew the hex nut (key 67) and remove the spacer (key 66) and spring (key 68). After removing the spring, replace the spacer (key 66) and hex nut (key 67) on the displacer rod.

From the displacer end, pull the displacer rod away from the sensor connection (key 65) to pull the pivot base (key 73) loose from the sensor connection. Remove the hex nut (key 67) to permit removing the displacer rod, pivot base, pivot body, and spacer from the sensor connection.

- Slide the pivot base (key 73), retaining ring (key 76), anti-extrusion ring (key 75), and O-ring (key 74) off the displacer rod. Remove the O-ring (key 77) and backup ring (key 78) from the pivot base.

Figure 7. Sensor

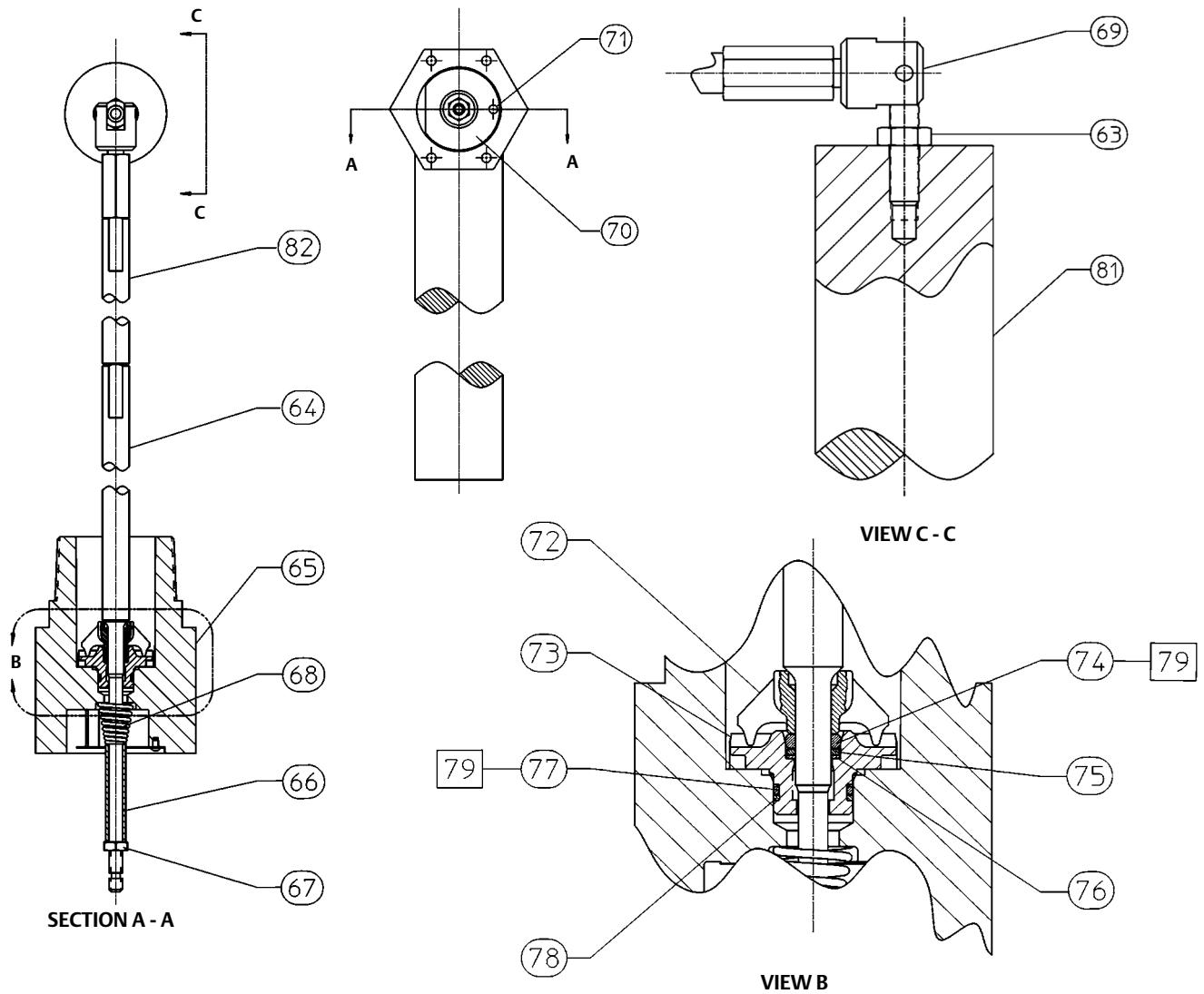

APPLY LUB/SEALANT

GB0139-C, sht 1

## Assembly

### **⚠ WARNING**

**Improper assembly of the O-rings, anti-extrusion ring, and backup ring could result in O-ring extrusion and permit leakage of process fluids. To avoid personal injury or property damage from leaking process fluid, be sure the O-rings, anti-extrusion ring and backup ring are assembled in the order shown in figure 7.**

1. Place the pivot body (key 72) on the displacer rod (key 64) so that it is positioned as shown in figure 7.
2. Slide the O-ring (key 74), anti-extrusion ring (key 75) and retaining ring (key 76) onto the displacer rod assembly (key 64). Be sure the O-ring, anti-extrusion ring, and retaining ring are in the order shown in figure 7. Slide the pivot base onto the displacer rod so that the points of the pivot body (key 72) will engage the slots in the pivot base (key 73).
3. Install the O-ring (key 77) and backup ring (key 78) into the groove on the pivot base (key 73). Be sure the backup ring is on the downstream pressure side of the O-ring as shown in figure 7.
4. Insert the displacer rod (key 64) into the vessel side of the sensor connection (key 65).
5. The pivot base must seat in the slots cast in the sensor connection. These slots will be horizontal when the sensor connection (key 65) is oriented as shown in figure 2.
6. To reduce the possibility of nicking the O-ring (key 77) on the pivot base, keep the displacer rod centered in the sensor connection as much as possible while pushing the pivot base into the sensor connection. Be sure the pivot base seats in the slots cast in the sensor connection.
7. Slide the spring (key 68) and spacer (key 66) onto the displacer rod and secure with the hex nut (key 67). Fully tighten the hex nut (key 67).
8. View the sensor connection from the vessel side. Ensure that the pivot body arms remain aligned with the pivot base arms (the two pivot body points are seated in the pivot base slots).
9. Install the sensor on the tank.

## Replacing the Controller Relay

Refer to figure 8 for key number locations unless otherwise indicated.

1. Disconnect the supply and output pressure lines.
2. Remove the two relay mounting screws (key 33), and pull the relay away from the controller base (key 1).
3. Install the new relay using two relay mounting screws (key 33). Make certain that the relay mounting O-rings (keys 43 and 44, not shown) are completely in their mounting bosses before installing the relay. Make certain span lever B (see figure 5) is in line with and pushing in on the end of either the relay adjustment screw (key 49, throttling controller) or the pilot valve plug of the valve assembly (key 51, snap-acting controller).

## Replacing the Controller Supply Filter

Refer to figure 8 for key number locations unless otherwise indicated.

1. Disconnect the supply and output pressure lines.
2. Loosen the filter cap screws (key 17), and rotate the filter cap (key 14) to the side to uncover the supply filter (key 15).
3. Remove the old filter (key 15), and remove any debris from the filter boss.
4. Install a new supply filter. Reinstall the filter cap (key 14), and tighten the filter cap screws (key 17).

## Related Documents

- Converting a Threaded NPT Connection to a Flange Connection—Supplement to Fisher L2, L2e and L2sj Liquid Level Controller Instruction Manuals ([D103277X012](#))
- Dimensions for NPS 2 CL150 through 1500 Slip On Flange Connections—Supplement to Fisher L2, L2e, and L2sj Liquid Level Controller Instruction Manuals ([D103405X012](#))
- Fisher L2sj Low Emission Liquid Level Controller Instruction Manual ([D103216X012](#))

All documents are available from your [Emerson sales office](#) or Fisher.com.

## Parts Ordering

When corresponding with your Emerson sales office about this equipment, always mention the serial number of the controller. The serial number can be found on the nameplate (key 55, figure 8).

### **⚠ WARNING**

**Use only genuine Fisher replacement parts. Components that are not supplied by Emerson should not, under any circumstances, be used in any Fisher instrument. Use of components not supplied by Emerson may void your warranty, might adversely affect the performance of the valve, and could cause personal injury or property damage.**

## Parts Kits

Description	Part Number
<b>Controller</b> Repair kit includes O-rings (keys 13 and 16) and gaskets (keys 18, 21, and 23)	RL2CNTRX012
<b>Relay</b> Repair kits includes relay assembly, relay mounting screws (key 33), and O-rings (keys 43 and 44)	
Throttling and On/Off Controller	GB0138X0012
Snap-Acting Controller	GB0138X0022
<b>Sensor</b> Repair kit includes keys 74, 75, 77, and 78 (fluorocarbon O-rings, anti-extrusion ring, and fluorocarbon backup ring)	RL2SENSX012

## Parts List

### Controller

Key	Description
1	Controller Base
2	Zero Spring Seat
3	Zero Adjustment Bolt
4	Spring Adjustment
5	Zero Spring

Figure 8. Fisher L2 Liquid Level Controllers

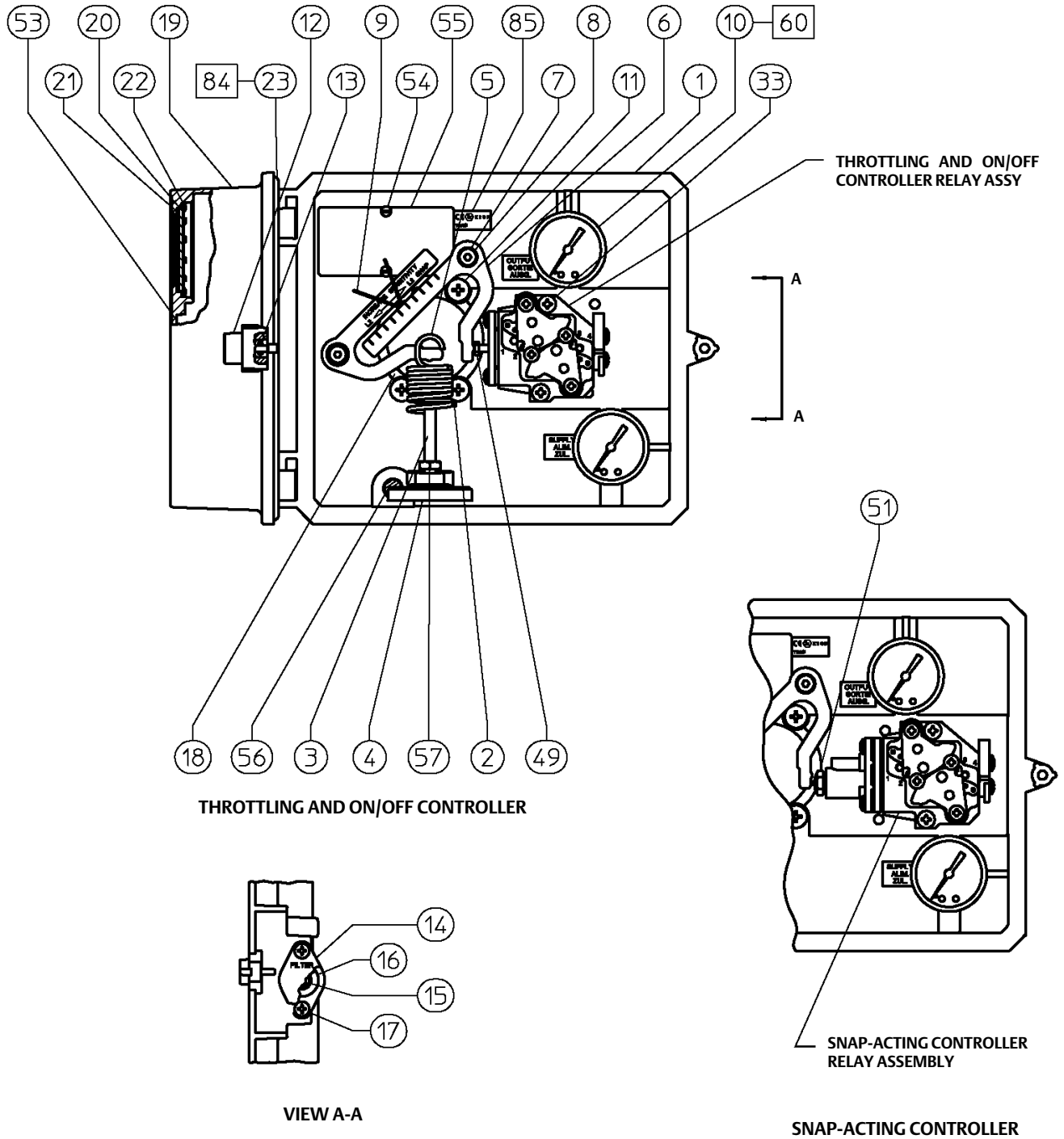

□ APPLY LUB/SEALANT

GB0137-D



Key	Description
6	Span Lever Assembly
7	Shoulder Screw (2 req'd)
8	Flanged Bearing (4 req'd)
9	Span Adjustor
10	Pressure Gauge (2 req'd)
11	Mounting Screw (4 req'd)
12	Cover Screw
13*	O-Ring <sup>(1)</sup>
14	Filter Cap
15	Filter
16*	O-Ring <sup>(1)</sup>
17	Machine Screw (2 req'd)
18*	Sensor Gasket <sup>(1)</sup>
19	Cover
20	Cover Lens (2 req'd)
21*	Gasket <sup>(1)</sup> (2 req'd)
22	Retaining Ring (2 req'd)
23*	Cover Gasket <sup>(1)</sup>
33	Relay Mounting Screw <sup>(2)</sup> (2 req'd)
43*	Relay Mounting O-Ring <sup>(2)</sup> (not shown)
44*	Relay Mounting O-Ring <sup>(2)</sup> (not shown)
49	Relay Adjustment Screw
51	Valve Assembly
52	Valve Assembly O-Ring
53	Label, setup and calibration
54	Self-Tapping Screw (2 req'd)
55	Nameplate
56	Screen

Key	Description
57	Hex Nut
60	Anti-seize sealant (not furnished with controller)
61	Lubricant (not furnished with controller)
62	Thread locking adhesive, medium strength (not furnished with controller)
84	Adhesive
85	Nameplate, ATEX

## Sensor

81	Displacer, 1-7/8x12-inches
63	Hex Nut
64	Displacer Rod
65	Sensor Connection
66	Spacer
67	Hex Nut
68	Conical Spring
69	Universal Joint (vertical displacer only)
70	Nameplate
71	Drive Screw
72	Pivot Body
73	Pivot Base
74*	O-Ring <sup>(3)</sup>
75*	Anti-Extrusion Ring <sup>(3)</sup>
76	Retaining Ring
77*	O-Ring <sup>(3)</sup>
78*	Backup Ring <sup>(3)</sup>
79	Lithium grease (not furnished with sensor)
80	Instruction Tag
82	Extension

\*Recommended spare parts

1. Included in Controller Repair Kit

2. Included in Relay Repair Kit

3. Included in Sensor Repair Kit

Neither Emerson, Emerson Automation Solutions, nor any of their affiliated entities assumes responsibility for the selection, use or maintenance of any product. Responsibility for proper selection, use, and maintenance of any product remains solely with the purchaser and end user.

Fisher is a mark owned by one of the companies in the Emerson Automation Solutions business unit of Emerson Electric Co. Emerson Automation Solutions, Emerson, and the Emerson logo are trademarks and service marks of Emerson Electric Co. All other marks are the property of their respective owners.

The contents of this publication are presented for informational purposes only, and while every effort has been made to ensure their accuracy, they are not to be construed as warranties or guarantees, express or implied, regarding the products or services described herein or their use or applicability. All sales are governed by our terms and conditions, which are available upon request. We reserve the right to modify or improve the designs or specifications of such products at any time without notice.

Emerson Automation Solutions  
 Marshalltown, Iowa 50158 USA  
 Sorocaba, 18087 Brazil  
 Cernay, 68700 France  
 Dubai, United Arab Emirates  
 Singapore 128461 Singapore

[www.Fisher.com](http://www.Fisher.com)

