



780.897.5869
BURKECALIBRATION.COM

Miquelon Daniel Senior Orifice Fitting 2"–16" Manual

Questions? Call us at 780-897-5869 or email info@burkecalibration.com

Daniel™ Senior™ Orifice Fitting 2"-16"

2"- 16" 150-1500 / 2"-12" 2500

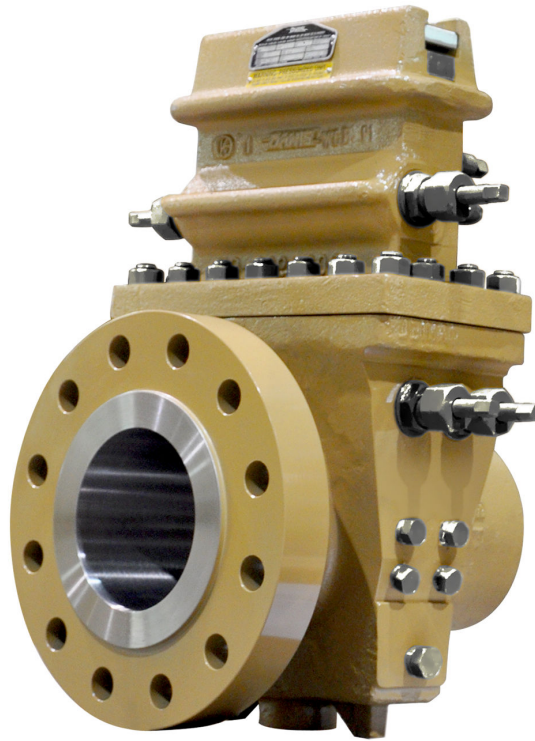

Signal words and symbols

Pay special attention to the following signal words, safety alert symbols and statements:



Safety alert symbol

This is a safety alert symbol. It is used to alert you to potential physical injury hazards. Obey all safety messages that follow this symbol to avoid possible injury or death.



DANGER

Danger indicates a hazardous situation which, if not avoided, will result in death or serious injury.



WARNING

Warning indicates a hazardous situation which, if not avoided, could result in death or serious injury.



CAUTION

Caution indicates a hazardous situation which, if not avoided, could result in minor or moderate injury.

NOTICE

Notice is used to address safety messages or practices not related to personal injury.

Important

Important is a statement the user needs to know and consider.

Tip

Tip provides information or suggestions for improved efficiency or best results.

Note

Note is “general by-the-way” content not essential to the main flow of information.

Important safety instructions

Daniel Measurement and Control, Inc. (Daniel) designs, manufactures and tests products to function within specific conditions. Because these products are sophisticated technical instruments, it is important that the owner and operation personnel must strictly adhere both to the information printed on the product and to all instructions provided in this manual prior to installation, operation, and maintenance.

Daniel also urges you to integrate this manual into your training and safety program.

BE SURE ALL PERSONNEL READ AND FOLLOW THE INSTRUCTIONS IN THIS MANUAL AND ALL NOTICES AND PRODUCT WARNINGS.

WARNING

Failure to follow the installation, operation or maintenance instructions for a Daniel product could lead to serious injury or death from explosion or exposure to dangerous substances.

To reduce the risk:

- Comply with all information on the product, in this manual, and in any local and national codes that apply to this product.
- Do not allow untrained personnel to work with this product.
- Use Daniel parts and work procedures specified in this manual.

Product owners (Purchasers):

- Use the correct product for the environment and pressures present. See technical data or product specifications for limitations. If you are unsure, discuss your needs with your Daniel representative.
- Inform and train all personnel in the proper installation, operation, and maintenance of this product.
- To ensure safe and proper performance, only informed and trained personnel should install, operate, repair and maintain this product.
- Verify that this is the correct instruction manual for your Daniel product. If this is not the correct documentation, contact Daniel at 1-713-827-6314. You may also download the correct manual from: <https://www.emerson.com/en-us/automation/daniel>.
- Save this instruction manual for future reference.
- If you resell or transfer this product, it is your responsibility to forward this instruction manual along with the product to the new owner or transferee.
- ALWAYS READ AND FOLLOW THE INSTALLATION, OPERATIONS, MAINTENANCE AND TROUBLESHOOTING MANUAL(S) AND ALL PRODUCT WARNINGS AND INSTRUCTIONS.
- Do not use this equipment for any purpose other than its intended service. This may result in property damage and/or serious personal injury or death.

Product operation (Personnel):

- To prevent personal injury, personnel must follow all instructions of this manual prior to and during operation of the product.
- Follow all warnings, cautions, and notices marked on, and supplied with, this product.
- Verify that this is the correct instruction manual for your Daniel product. If this is not the correct documentation, contact Daniel at 1-713-827-6314. You may also download the correct manual from: <https://www.emerson.com/en-us/automation/daniel>.
- Read and understand all instructions and operating procedures for this product.
- If you do not understand an instruction, or do not feel comfortable following the instructions, contact your Daniel representative for clarification or assistance.
- Install this product as specified in the INSTALLATION section of this manual per applicable local and national codes.
- Follow all instructions during the installation, operation, and maintenance of this product.
- Ensure that all connections to pressure and electrical sources are secure prior to and during equipment operation.
- Use only replacement parts specified by Daniel. Unauthorized parts and procedures can affect this product's performance, safety, and invalidate the warranty. "Look-a-like" substitutions may result in deadly fire, explosion, release of toxic substances or improper operation.
- Save this instruction manual for future reference.

Notice

THE CONTENTS OF THIS PUBLICATION ARE PRESENTED FOR INFORMATIONAL PURPOSES ONLY, AND WHILE EVERY EFFORT HAS BEEN MADE TO ENSURE THEIR ACCURACY, THEY ARE NOT TO BE CONSTRUED AS WARRANTIES OR GUARANTEES, EXPRESSED OR IMPLIED, REGARDING THE PRODUCTS OR SERVICES DESCRIBED HEREIN OR THEIR USE OR APPLICABILITY. ALL SALES ARE GOVERNED BY DANIEL'S TERMS AND CONDITIONS, WHICH ARE AVAILABLE UPON REQUEST. WE RESERVE THE RIGHT TO MODIFY OR IMPROVE THE DESIGNS OR SPECIFICATIONS OF SUCH PRODUCTS AT ANY TIME.

DANIEL DOES NOT ASSUME RESPONSIBILITY FOR THE SELECTION, USE OR MAINTENANCE OF ANY PRODUCT. RESPONSIBILITY FOR PROPER SELECTION, USE AND MAINTENANCE OF ANY DANIEL PRODUCT REMAINS SOLELY WITH THE PURCHASER AND END-USER.

TO THE BEST OF DANIEL'S KNOWLEDGE THE INFORMATION HEREIN IS COMPLETE AND ACCURATE. DANIEL MAKES NO WARRANTIES, EXPRESSED OR IMPLIED, INCLUDING THE IMPLIED WARRANTIES OF MERCHANTABILITY AND FITNESS FOR A PARTICULAR PURPOSE WITH RESPECT TO THIS MANUAL AND, IN NO EVENT, SHALL DANIEL BE LIABLE FOR ANY INCIDENTAL, PUNITIVE, SPECIAL OR CONSEQUENTIAL DAMAGES INCLUDING, BUT NOT LIMITED TO, LOSS OF PRODUCTION, LOSS OF PROFITS, LOSS OF REVENUE OR USE AND COSTS INCURRED INCLUDING WITHOUT LIMITATION FOR CAPITAL, FUEL AND POWER, AND CLAIMS OF THIRD PARTIES.

PRODUCT NAMES USED HEREIN ARE FOR MANUFACTURER OR SUPPLIER IDENTIFICATION ONLY AND MAY BE TRADEMARKS/ REGISTERED TRADEMARKS OF THESE COMPANIES.

Warranty and Limitations

1. LIMITED WARRANTY: Subject to the limitations contained in Section 2 herein, Daniel Measurement & Control, Inc. ("Daniel") warrants that the licensed firmware embodied in the Goods will execute the programming instructions provided by Daniel, and that the Goods manufactured by Daniel will be free from defects in materials or workmanship under normal use and care and Services will be performed by trained personnel using proper equipment and instrumentation for the particular Service provided. The foregoing warranties will apply until the expiration of the applicable warranty period. Goods are warranted for twelve (12) months from the date of initial installation or eighteen (18) months from the date of shipment by Daniel, whichever period expires first. Consumables and Services are warranted for a period of 90 days from the date of shipment or completion of the Services. Products purchased by Daniel from a third party for resale to Buyer ("Resale Products") shall carry only the warranty extended by the original manufacturer. Buyer agrees that Daniel has no liability for Resale Products beyond making a reasonable commercial effort to arrange for procurement and shipping of the Resale Products. If Buyer discovers any warranty defects and notifies Daniel thereof in writing during the applicable warranty period, Daniel shall, at its option, correct any errors that are found by Daniel in the firmware or Services or repair or replace F.O.B. point of manufacture that portion of the Goods or firmware found by Daniel to be defective, or refund the purchase price of the defective portion of the Goods/Services. All replacements or repairs necessitated by inadequate maintenance, normal wear and usage, unsuitable power sources or environmental conditions, accident, misuse, improper installation, modification, repair, use of unauthorized replacement parts, storage or handling, or any other cause not the fault of Daniel are not covered by this limited warranty, and shall be at Buyer's expense. Daniel shall not be obligated to pay any costs or charges incurred by Buyer or any other party except as may be agreed upon in writing in advance by Daniel. All costs of dismantling, reinstallation and freight and the time and expenses of Daniel's personnel and representatives for site travel and diagnosis under this warranty clause shall be borne by Buyer unless accepted in writing by Daniel. Goods repaired and parts replaced by Daniel during the warranty period shall be in warranty for the remainder of the original warranty period or ninety (90) days, whichever is longer. This limited warranty is the only warranty made by Daniel and can be amended only in a writing signed by Daniel. THE WARRANTIES AND REMEDIES SET FORTH ABOVE ARE EXCLUSIVE. THERE ARE NO REPRESENTATIONS OR WARRANTIES OF ANY KIND, EXPRESS OR IMPLIED, AS TO MERCHANTABILITY, FITNESS FOR PARTICULAR PURPOSE OR ANY OTHER MATTER WITH RESPECT TO ANY OF THE GOODS OR SERVICES. Buyer acknowledges and agrees that corrosion or erosion of materials is not covered by this warranty.

2. LIMITATION OF REMEDY AND LIABILITY: Daniel shall not be liable for damages caused by delay in performance. The remedies of Buyer set forth in this agreement are exclusive. In no event, regardless of the form of the claim or cause of action (whether based in contract, infringement, negligence, strict liability, other tort or otherwise), shall Daniel's liability to Buyer and/or its customers exceed the price to Buyer of the specific goods manufactured or services provided by Daniel giving rise to the claim or cause of action. Buyer agrees that in no event shall Daniel's liability to Buyer and/or its customers extend to include incidental, consequential or punitive damages. The term "consequential damages" shall include, but not be limited to, loss of anticipated profits, revenue or use and costs incurred including without limitation for capital, fuel and power, and claims of Buyer's customers.

Contents

Part I Plan

Chapter 1	Introduction.....	13
	1.1 Definition of Acronyms.....	13
	1.2 Purpose of this manual.....	14
	1.3 Product description.....	14
	1.4 Conditions and specifications.....	16
	1.5 Parts and materials lists.....	20

Part II Install

Chapter 2	General Information.....	53
	2.1 Installation.....	53

Part III Operate

Chapter 3	Commissioning.....	63
	3.1 Commission the Daniel Senior Orifice Fitting.....	63
	3.2 Commission the line pressure test.....	65
	3.3 Orifice Plate Installation.....	67

Part IV Maintain

Chapter 4	Normal operation conditions.....	73
	4.1 Maintenance.....	73
	4.2 Orifice plate installation and removal instructions.....	78
Chapter 5	Supplemental information.....	165
	5.1 Recommended spare parts for a one-year operation.....	165
	5.2 Lubricant information.....	166
	5.3 Torque information.....	170
	5.4 Plate and Valve Carrier clearances.....	173

Part I

Plan

1 Introduction

1.1 Definition of Acronyms

Table 1-1: Acronyms and their definition

Acronym	Description
AGA	American Gas Association
AISI	American Iron and Steel Institute
API	American Petroleum Institute
ANSI	American National Standards Institute
ASME	American Society of Mechanical Engineers
ASTM	American Society of Testing and Materials
GPA	Gas Processors Association
ISO	International Organization of Standardization
MSS	Manufacturers Standardization Society of the Valve and Fittings Industry, Inc
NACE	NACE International (formerly National Association of Corrosion Engineers)
MPMS	API Manual of Petroleum Measurement Standards
API-14.3	API-AGA joint flow measurement code (API MPMS Chapter 14, Section 3, Part 2:2000(R2011) - also AGA Report No. 3, Part 2 and GPA 8185-00, Part 2)
ISO 5167	ISO flow measurement code (ISO 5167-2:2003(E))
U/S	upstream
D/S	downstream
DP	differential pressure (ΔP) - differences of static pressures found on the U/S and D/S faces of an orifice plate during the flow measurement process
CRS	cold rolled steel
CS	carbon steel
SS	stainless steel
YP	gold (yellow chromate) zinc plated
ZP	silver (clear chromate) zinc plated
MAOP	maximum allowable operating pressure
NPSM	national pipe straight mechanical thread
NPT	national pipe tapered thread
HBR	butadiene rubber

Table 1-1: Acronyms and their definition (continued)

Acronym	Description
HNBR	hydrogenated nitrile-butadiene rubber
NBR	nitrile-butadiene rubber
FFKM	perfluoroelastomer rubber
FKM	fluoroelastomer rubber
PTFE	polytetrafluoroethylene
SBR	styrene-butadiene rubber
TFE	tetrafluoroethylene

1.2 Purpose of this manual

This manual provides guidance to owners and personnel in the installation, operation and maintenance of the *Daniel™ Senior™ Orifice Fitting*.

To ensure safe and proper installation, operation and maintenance, it is imperative that product owners and operation personnel read and follow the information contained in this manual.

1.3 Product description

The Daniel Senior Orifice Fitting is an orifice plate holding device that houses, and accurately positions, an orifice plate within a pipe or tube to measure fluid flow. It is one component of a flow measurement system. The Senior Orifice Fitting (Senior) is designed to:

- Position an orifice plate, concentric to flow moving through a pipeline, within API -14.3, Part 2 or ISO 5167 installation requirements.
- Allow personnel to remove and replace an orifice plate without disturbing the flow measurement system piping, with little, or no, interruption in service and without removing the Senior from the system.

The orifice plate within a Senior restricts the fluid moving through a pipe. This restriction creates a change in static pipe pressure of the fluid. Instrumentation measure the difference in change of the fluid entering orifice plate bore, and once again after it exits the plate bore. This instrumentation then combines that information, along with other data gathered from the flowing fluid, and calculates the amount of fluid that passes through the system.

The first chamber, or Body (4), properly positions the orifice plate in the flow stream. The second chamber, or Top (14), is a temporary holding place for the orifice plate during removing or installing operations (Refer to [Orifice plate installation and removal instructions](#)).

Important

The unit components have part numbers assigned on appropriate drawings and tables. Refer to [Figure 1-2](#) thru [Figure 1-5](#) and [Table 1-4](#) thru [Table 1-8](#) for part numbers. Example: Body (4).

Figure 1-1: Daniel Senior Orifice Fitting - Flangnek option

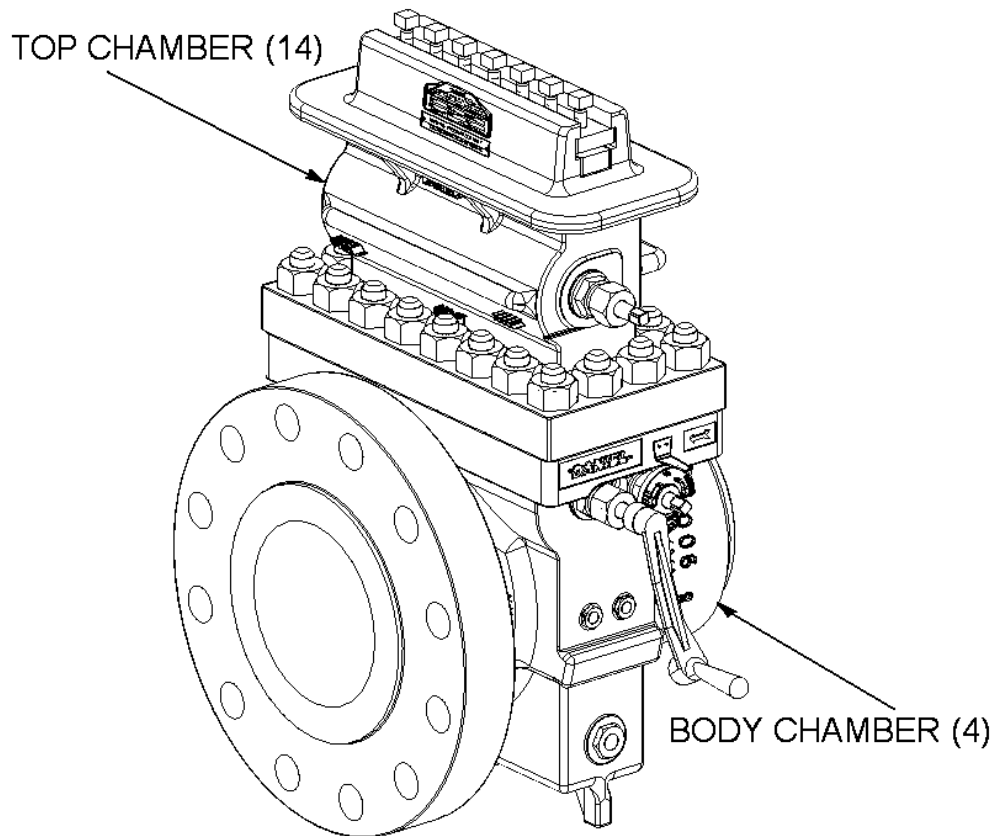

Therefore, using a Senior may eliminate the need for bypass piping, valves, and other fittings necessary with conventional orifice fitting installations. Maintenance technicians can replace and repair all parts of the Senior, including the slide valve assembly, without removing the Body (4) from the line (refer to [Maintain](#)).

Emerson designs and manufactures all Senior units to applicable API-14.3 recommendations and in accordance with selected ANSI, ASME and ASTM specifications. As an option, Emerson Process Management also designs and manufactures fittings in compliance with ISO 5167.

Products bearing the "CE" mark are designed and manufactured in compliance with the European Union Pressure Equipment Directive (PED) 97/23/EC (available on the internet).

Refer to the "Daniel Orifice Fittings Installation and Operating Instructions specific to the Pressure Equipment Directive", Part Number 3-9008-002 (available on the Emerson Process Management website).

White papers (available on the Emerson Process Management website, Daniel products section):

- Upp, E.L. "Application of the Orifice Meter for Accurate Gas Flow Measurement": Daniel Measurement and Control Inc., Houston, Texas USA (1995)
- Upp, E.L. "Development of Orifice Meter Standards": Daniel Measurement and Control Inc., Houston, Texas USA (1995)
- Daniel Measurement and Control Inc. "Fundamentals of Orifice Meter Measurement": Daniel Measurement and Control Inc., Houston, Texas USA (1997)
- Kendrick, Ray. Effects of the Latest Revision of ANSI/API 2530/AGA 3 On Orifice Meter Primary Elements" Daniel Measurement and Control Inc., Houston, Texas USA (1997)
- Daniel Measurement and Control Inc. "Getting the Best Value From Daniel Senior Orifice Fittings": Daniel Measurement and Control Inc., Houston, Texas USA (1997)
- Cotton, Galen M. "Pulsation Effects on Gas Measurement": Daniel Measurement and Control Inc., Houston, Texas USA (1980)
- Husain, Zaki D. "Theoretical Uncertainty of Orifice Flow Measurement": Daniel Measurement and Control Inc., Houston, Texas USA (1990)
- Daniel Measurement and Control Inc. "Senior Orifice Fitting Technical Guide: DAN-DIF-TG11-1003 "Daniel Measurement and Control Inc., Houston, Texas USA (2014).

1.4 Conditions and specifications

NOTICE

Follow all the safety and equipment limits recommended in [Conditions and specifications](#) of this manual.

It is the owner's and/or purchaser's responsibility to comply with these parameters.

WARNING

PERSONAL PROTECTION HAZARD

Follow all parameters for the Senior Orifice indicated below.

Failure to comply may result in death and serious injury or equipment damage.

Table 1-2: Conditions and specifications

Product parameters and limitations:	
Fluid static pressures	Refer to ASME/ANSI B16 standards, and your fitting's material of construction, to determine the maximum operating temperature and pressure of your Senior. Emerson provides both the fitting's materials of construction and ASME/ANSI ratings information on the product nameplate.
Fluid phases:	Gas, liquid, vapor
Fluids measured:	Most fluids
Fluid temperature parameters:	-20° / +160° F (-29° C / +71° C) is the fluid temperature range for this product based upon the materials of construction (Refer to ASME codes ⁽¹⁾). Consult factory before operating this product outside of the specified temperature range.

Table 1-2: Conditions and specifications (continued)

Temperature and operating pressure limitations of Orifice Plate Seal materials:	<p>-20° / +160° F (-29° C / +71° C) is the fluid temperature range for this product based upon the materials of construction (Refer to ASME codes ⁽¹⁾).</p> <p>The following list describes the most common Orifice Plate Seal material and their available forms offered for use in Daniel Senior fittings.</p> <p>Consult factory before operating this product outside of the specified temperature range.</p>	
	HNBR:	<p>Loose or Bonded:</p> <p>Material available for "loose" seal rings (2"-10") or "bonded" seal to orifice plates (12" and larger). Operating pressure is limited to lesser of ANSI Class MAOP or 1500 psig.</p> <p>O-ring:</p> <p>Used with Snap Seal Ring assemblies (2" and larger). Operating pressure is limited to ANSI Class MAOP.</p>
	NBR:	<p>Loose or Bonded:</p> <p>Material available for "loose" seal rings (2"-10") or "bonded" seal to orifice plates (12" and larger). Operating pressure is limited to lesser of ANSI Class MAOP or 1500 psig.</p>
	FKM:	<p>Loose or Bonded:</p> <p>Material available for "loose" seal rings (2"-10") or "bonded" seal to orifice plates (12" and larger). Operating pressure is limited to lesser of ANSI Class MAOP or 1500 psig.</p> <p>"O" Ring:</p> <p>Used with Snap Seal Ring assemblies (2" and larger). Operating pressure is limited to ANSI Class MAOP.</p>
	PTFE:	<p>Loose:</p> <p>Material used for orifice plate seal rings (2" and above). Operating pressure is limited to ANSI Class MAOP.</p>
	FFKM:	<p>"O" Ring:</p> <p>Used with Snap Seal Ring assemblies (2" and larger). Operating pressure is limited to ANSI Class MAOP.</p>
Differential pressure:	Refer to API -14.3 or ISO 5167, as appropriate to your system.	
General arrangement dimensions:		
See List item .		
Time parameters:		
See Orifice Plate changing instructions		
Components:		
Maintenance intervals:	<p>The owners and users of these products should perform regular scheduled intervals of maintenance activities. The recommended intervals are every month or as directed by the owner's maintenance procedures. Examine components during each scheduled maintenance period, site visits and during each orifice plate change.</p> <p>Replace any component that shows signs of wear or when damaged with parts specified for Daniel products.</p>	

Table 1-2: Conditions and specifications (continued)

Seal replacement:	Examine seals during each scheduled maintenance period, site visits and during each orifice plate change. Replace any worn or damaged or non-functioning seals with parts specified for Daniel product.
Fastener torque verification:	Check all fasteners for tightness during each scheduled maintenance period, site visits and during each orifice plate change. Use information provided in Section 5.3 as a starting point in establishing the proper fastener torque values for your particular service environment.
Corrosion allowance:	Emerson machines the meter bore of each fitting to close tolerances. This is to conform to industry measurement standards. The fitting's meter bore dimensions DO NOT include an allowance for corrosion. It is the end user's responsibility to specify a fitting's material of construction based upon their knowledge of the process fluid and environmental conditions of an intended service. Therefore, it is important that the end user to monitor any change in the gas or liquid composition during monthly exercises, site visits and plate changes that may create a corrosion concern (Reference: U.S. DOT, CFR Title 49: Part 192.477).
Environmental parameters:	
Application:	Surface and offshore (not for use in subsea applications)
Confined/open:	Designed for outdoor use. May be used in well ventilated spaces (buildings/ enclosed meter houses). Installation at product owner's discretion.
Site temperature:	Recommended atmospheric temperature ranges Maximum: +120 °F (+49 °C), Minimum: -20 °F (-29 °C).
Site humidity:	No limit
Site elevation:	No limit
Proximity to population:	Reference: Class 1 location: U.S. DOT, CFR Title 49: Part 192.5.
Proximity to traffic:	The owner must protect the fitting from accidental damage by vehicular traffic or other causes, by either placing the unit at a safe distance from the traffic, or installing barricades around the unit.
Proximity to equipment:	Install the Senior in a well ventilated place, not less than 3 feet (914 millimeters) from any source of ignition or any source of heat which might damage the unit.
Interface parameters:	
Replacement parts:	Use only replacement parts specified for Daniel products. Unauthorized parts and procedures can affect this product's performance and place the safe operation of your process at risk.
Aftermarket attachments:	Use of pressure sensing equipment, drain valves, and other accessories (e.g., needle valves, multi-port valves, transmitters, 3-pin recorders... etc.) are permissible. The use of aftermarket equipment must be installed and operated as directed by the after-market equipment manufacturer, and their warranties and replacements are not contained within the scope of this document.

Table 1-2: Conditions and specifications (continued)

Pipe supports:	<p>The owner must employ sound engineering principles to design the support systems for the flow measurement system (or meter tube).</p> <p>It is important that the design engineer develop a method to support the entire weight (equipment, piping and fluid) of the system.</p> <p>The method developed must prevent bending to reduce the potential of creating unwanted stress at welded joints and flanges. Unwanted stresses may lead to leaks and may ultimately lead to failure or rupture of the flow measurement system.</p>
Vandalism/ Tampering:	<p>It is the responsibility of each product owner to protect the Senior from vandalism, tampering or other unauthorized activity.</p>

(1) *It is ultimately the responsibility of the Owner or End User to determine suitable materials of construction suitable for a service conditions.*

1.5 Parts and materials lists

1.5.1 Trim options

Table 1-3: Senior Fitting Trim options⁽¹⁾

"A"	Materials offered for liquid or dry gaseous, non-corrosive ("sweet") fluids
"NACE"	Materials offered for dry, non-corrosive ("sour") H ₂ S-containing gases
AASG	Materials offered for liquid or wet gaseous, mildly corrosive ("sour") H ₂ S-containing fluids
316SS PIC	Materials offered for liquid or wet gaseous, moderately corrosive ("sour") H ₂ S-containing fluids
22CR duplex	Materials offered for liquid or wet gaseous, severely corrosive ("sour") H ₂ S-containing fluids
Mildly corrosive	≤3.0 mpy
Moderately corrosive	> 3.0 - 8.0 mpy
Severely corrosive	>8.0 mpy
mpy = mils (0.001") penetration per year of corrosion based on carbon steel	
NOTICE It is the ultimate responsibility of the owner and/or purchaser to specify a fitting's material of construction, including trim option, based upon their knowledge of the process fluid and environmental conditions of an intended service.	

(1) Unless otherwise noted, materials as listed in the Parts Lists indicate standard "A" Trim product. For applications outside all parameters listed, please consult the factory.

1.5.2 Daniel Senior Orifice Fitting sizes 2"- 8" 150-900

Figure 1-2: Daniel Orifice Fitting drawing 2"-8" 150-900

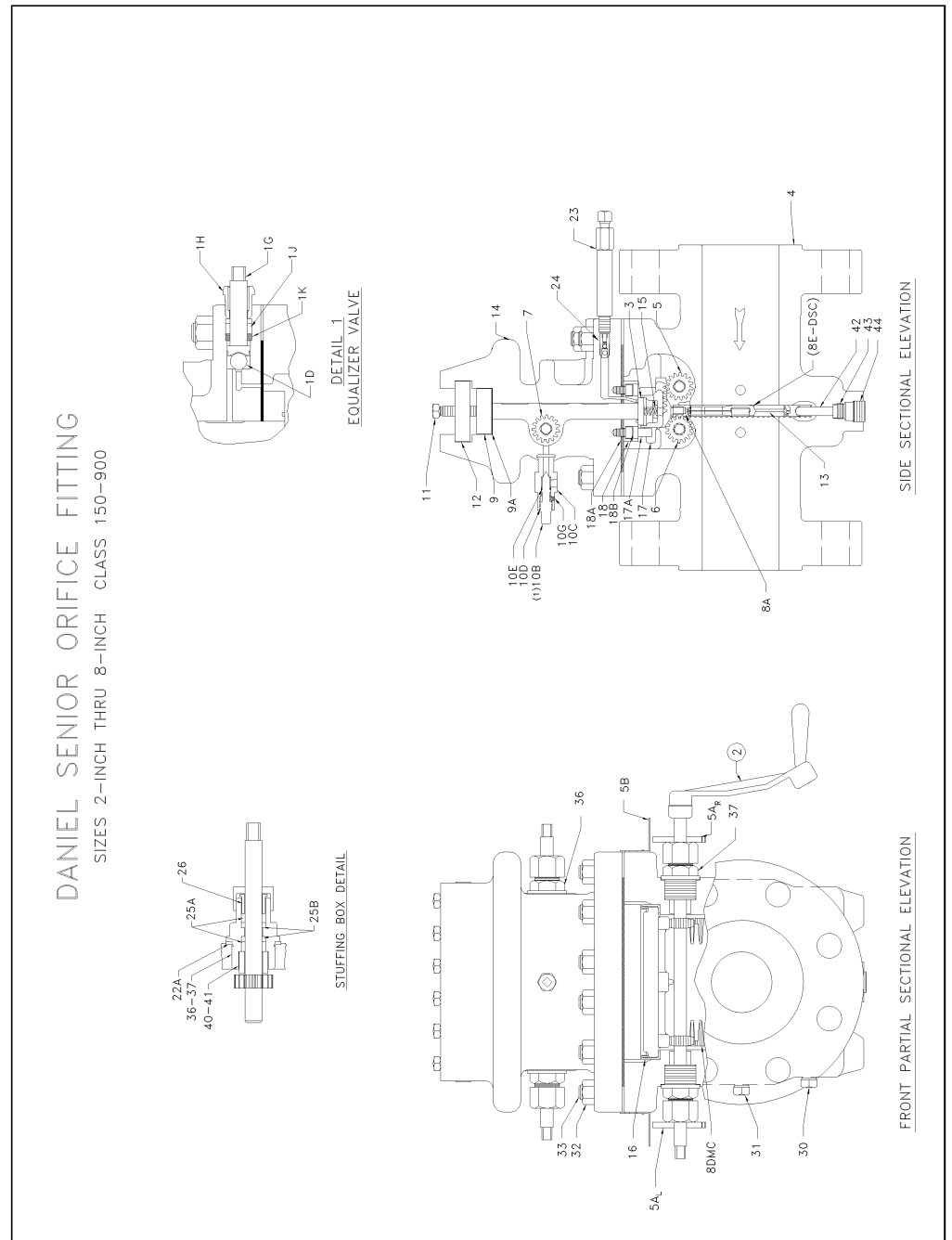

All Parts on Daniel Senior Orifice Fittings may be replaced or repaired without removing the Daniel Senior Orifice Fitting body from the line.

Table 1-4: Daniel Senior Orifice Fitting sizes 2" - 8" 150-600

Item number	Description	Material	Quantity required				
			Size				
			2"	3"	4"	6"	8"
1 *	Equalizer valve (complete):						
1G*	Stem	316 SS	1	1	1	1	1
1H*	Packing nut	CS (ZP)	1	1	1	1	1
1D*	Ball	Tungsten-Carbide	1	1	1	1	1
1K*	Packing washer	17-4PH SS	1	1	1	1	1
1J*	Packing ring	TFE/PTFE	2	2	2	2	2
2*	Operating wrench	Ductile iron	1	1	1	1	1
3	Slide valve trip	Type 410	1	1	1	1	1
4	Body	Cast carbon steel	1	1	1	1	1
5	Slide valve shaft	316 SS	1	1	1	1	1
5A-LH*	Indicator plate left-hand	Cast aluminum	1	1	1	1	1
5A-RH*	Indicator plate right-hand	Cast aluminum	1	1	1	1	1
5B*	Indicator pointer	Aluminum	2	2	2	2	2
5C	Drive screws	18-8 SS	4	4	4	4	4
6	Lower plate carrier shaft	316 SS	1	1	1	1	1
7	Upper plate carrier shaft	316 SS	1	1	1	1	1
8A*	Plate carrier spring pin	18-8 SS	1	1	1	1	1
8DMC	Plate carrier	316 SS	1	1	1	1	1
8E-DSC	Orifice plate sealing unit 150-600	NBR (Removable - orifice plate not included)	1	1	1	1	1
8TSC	Optional Orifice plate sealing unit 150-600	TFE/PTFE (Removable - orifice plate not included)	1	1	1	1	1
8 MSC	Optional Snap Seal Ring units for special services	CS (ZP) (Removable - orifice plate not included)	1	1	1	1	1
8 SNC	Optional Snap Seal Ring units for special services	CS (ZP) or SS w/O-rings (Removable - orifice plate not included)	1	1	1	1	1
9	Sealing bar	CS (ZP)	1	1	1	1	1
9A	Sealing bar gasket	Composite	1	1	1	1	1
10B	Bleeder Valve (complete)						
10C*	Body	CS (ZP)	1	1	1	1	1

Table 1-4: Daniel Senior Orifice Fitting sizes 2" - 8" 150-600 (continued)

Item number	Description	Material	Quantity required				
			Size				
			2"	3"	4"	6"	8"
10D*	Needle	316 SS	1	1	1	1	1
10E*	O-ring	Synthetic rubber	1	1	1	1	1
10G*	Set screw	Alloy steel	1	1	1	1	1
11*	Clamping bar screw	Alloy steel (ZP)	4 ⁽¹⁾	4 ⁽¹⁾	5 ⁽¹⁾	6 ⁽¹⁾	7 ⁽¹⁾
12	Clamping bar	CS (ZP)	1	1	1	1	1
13	Orifice plate	Type 304 SS or 316 SS	1	1	1	1	1
14	Top	Cast carbon steel	1	1	1	1	1
15*	Slide valve springs	Inconel X-750	4	4	4	6	6
16*	Slide valve carrier guide	316 SS	2	2	2	2	2
17	Slide valve carrier	Cast carbon steel	1	1	1	1	-
		Cast Alloy Iron	-	-	-	-	1
17A*	Slide valve carrier stop pin	Carbon steel (ZP)	2	2	2	2	2
18	Slide valve seat	13% chrome SS	1	1	1	1	1
18A*	Slide valve seat/top gasket	Composite	1	1	1	1	1
18B*	Slide valve seat screw	Alloy steel phosphate treat	8	10	11	14	16
22A*	Bearing plug and stuffing box gasket	316 SS	6	6	6	6	6
23*	Grease gun (complete)	CS (ZP)	1	1	1	1	1
24*	Grease seal double ball check valve	316 SS with Tungsten-Carbide	1	1	1	1	1
25*	Packing nut	CS (ZP)	6	6	6	6	6
25A*	Packing rings	TFE/PTFE	12	12	12	12	12
25B*	Centering ring	TFE/PTFE	12	12	12	12	12
26*	Stuffing box gland	316 SS	6	6	6	6	6
30(1)*	Drain valve plug	CS (ZP)	1	1	1	1	1
31(1)*	½ N.P.T. plug for pressure meter tap	CS (chemically treated)	2	2	2	2	2
32	Hex nut	CS	14	15	15	18	19
33	Stud	Alloy steel	14	15	15	18	19
36*	Stuffing box (upper)	CS (ZP)	2	2	2	2	2
37*	Stuffing box (lower)	CS (ZP)	4	4	4	4	4

Table 1-4: Daniel Senior Orifice Fitting sizes 2" - 8" 150-600 (continued)

Item number	Description	Material	Quantity required				
			Size				
			2"	3"	4"	6"	8"
40	Stuffing box sleeve (upper)	CS (ZP)	2	2	2	2	2
41	Stuffing box sleeve (lower)	CS (ZP)	4	4	4	4	4
42*	Plate carrier stop pin	CS (ZP)	1	1	1	1	1
43*	Plate carrier stop pin lock screw	CS (ZP)	1	1	1	1	1
44*	Plate carrier stop pin access plug	CS (ZP)	1	1	1	1	1
	Slide valve lubricant (boxes)	Castor oil based solid sticks - 24 sticks per box	3	3	3	3	3

Notes for Table 1-4:

(1) All Daniel Senior Orifice Fittings are supplied with pipe plugs on the drains only. If pipe plugs for the measurement tap holes are required, please contact the factory directly.

- Locations of Equalizer Valve (1), Bleeder Valve (10B), and Grease Gun (23) may differ from diagrams shown in this manual.
- The clamping bar screw quantity and size listed here reflect ones used on our most common fitting for that size and pressure rating. The actual number and size of clamping bar screws may vary for that size and pressure rating due to a fitting's material of construction and configuration. When ordering replacements, or developing a maintenance program, always confirm the count and size of clamping bar screws of your fitting.
- Slide Valve Lubricant: 0.38 in (9.53 mm) diameter by 1.5 in (38.1 mm) long is equivalent to some lubricant manufacturers' "B" size stick. The quantity of lubricant a fitting described in this manual will require is dependent upon the state and condition of the fitting. Emerson recommends having one box of lubricant sticks (24 sticks per box) on-hand when performing maintenance and plate inspection/change procedures.

(*) Indicates interchangeable parts for all line sizes of specified pressure rating(s).

(¹) Indicates 1/2" - 13. See [Table 1](#) for clamping bar screw recommended torque values.

General notes for Table 1-4:

- The materials listed in [Table 1-4](#) indicate standard "NACE" trim.
- Materials of some items listed in [Table 1-4](#) are changed for the "AASG" trimmed fittings.
- Several available trim options are shown in [Table 1-3](#).
- Other trim options available upon request. Consult factory.
- Bolded item numbers are for parts which are fluid media PIC (parts in contact).

When ordering parts, please specify ⁽¹⁾

- Catalog number
- Size
- Serial number
- Item number
- Material
- Quantity of each item required

(1) Catalog number, size and serial number can be found on the fitting nameplate. Part item numbers and part materials for "NACE" trim only are found in Daniel Senior Orifice Fitting sizes 2" - 8" 150-900.

All Parts on Daniel Senior Orifice Fittings may be replaced or repaired without removing the Daniel Senior Orifice Fitting body from the line.

Table 1-5: Daniel Senior Orifice Fitting sizes 2"-8" 900

Item number	Description	Material	Quantity required				
			Size				
			2"	3"	4"	6"	8"
1 *	Equalizer valve (complete):						
1G*	Stem	316 SS	1	1	1	1	1
1H*	Packing nut	CS (ZP)	1	1	1	1	1
1D*	Ball	18-8 SS	1	1	1	1	1
1K*	Packing washer	17-4PH SS	1	1	1	1	1
1J*	Packing ring	TFE/PTFE	2	2	2	2	2
2*	Operating wrench	Ductile iron	1	1	1	1	1
3	Slide valve trip	Type 410 SS	1	1	1	1	1
4	Body	Cast carbon steel	1	1	1	1	1
5	Slide valve shaft	316 SS	1	1	1	1	1
5A-LH*	Indicator plate left-hand	Cast aluminum	1	1	1	1	1
5A-RH*	Indicator plate right-hand	Cast aluminum	1	1	1	1	1
5B*	Indicator pointer	Aluminum	2	2	2	2	2
5C	Drive screws	18-8 SS	4	4	4	4	4
6	Lower plate carrier shaft	316 SS	1	1	1	1	1
7	Upper plate carrier shaft	316 SS	1	1	1	1	1
8A*	Plate carrier spring pin	18-8 SS	1	1	1	1	1
8DMC	Plate carrier	316 SS	1	1	1	1	1
8TSC	Orifice plate sealing unit alternate seals available see catalog - #500	PTFE (Removable - orifice plate not included)	1	1	1	1	1
8 MSC	Optional Snap Seal Ring units for special services	CS (ZP) or 316 SS (plate not included)	1	1	1	1	1
8 SNC	Optional Snap Seal Ring units for special services	CS (ZP) or 316 SS w/O-rings (plate not included)	1	1	1	1	1
9	Sealing bar	CS (ZP)	1	1	1	1	1
9A	Sealing bar gasket	Composite	1	1	1	1	1
10B	Bleeder Valve (Complete)						
10C*	Body	CS (ZP)	1	1	1	1	1
10D*	Needle	316 SS	1	1	1	1	1
10E*	O-ring	Synthetic rubber	1	1	1	1	1

Table 1-5: Daniel Senior Orifice Fitting sizes 2"-8" 900 (continued)

Item number	Description	Material	Quantity required				
			Size				
			2"	3"	4"	6"	8"
10G*	Set screw	Alloy steel	1	1	1	1	1
11*	Clamping bar screw	Alloy steel (ZP)	4 ⁽¹⁾	4 ⁽¹⁾	5 ⁽¹⁾	6 ⁽¹⁾	7 ⁽²⁾
12	Clamping bar	CS (ZP)	1	1	1	1	1
13	Orifice plate	Type 304 SS or 316 SS	1	1	1	1	1
14	Top	Cast carbon steel	1	1	1	1	1
15*	Slide valve springs	316 SS	4	4	4	6	6
16*	Slide valve carrier guide	316 SS	2	2	2	2	2
17	Slide valve carrier	Cast carbon steel	1	1	1	1	-
		Cast Alloy Iron	-	-	-	-	1
17A*	Slide valve carrier stop pin	Carbon steel (ZP)	2	2	2	2	2
18	Slide valve seat	Cast alloy iron	1	1	1	1	-
		Cast iron	-	-	-	-	1
18A*	Slide valve seat/top gasket	Composite	1	1	1	1	1
18B*	Slide valve seat screw	Alloy steel phosphate treat	8	10	11	14	16
22A*	Bearing plug and stuffing box gasket	316 SS	6	6	6	6	6
23*	Grease gun (complete)	CS (ZP)	1	1	1	1	1
24*	Grease seal double ball check valve	316 SS with chrome-steel balls	1	1	1	1	1
25*	Packing nut	CS (ZP)	6	6	6	6	6
25A*	Packing rings	TFE/PTFE	12	12	12	12	12
25B*	Centering ring	TFE/PTFE	12	12	12	12	12
26*	Stuffing box gland	316 SS	6	6	6	6	6
30(1)*	Drain valve plug	CS (ZP)	1	1	1	1	1
31(1)*	½ N.P.T. plug for pressure meter tap	CS (chemically treated)	2	2	2	2	2
32	Hex nut	CS	14	15	15	18	20
33	Stud	Alloy steel	14	15	15	18	20
36*	Stuffing box (upper)	CS (ZP)	2	2	2	2	2
37*	Stuffing box (lower)	CS (ZP)	4	4	4	4	4
40	Stuffing box sleeve (upper)	CS (ZP)	2	2	2	2	2

Table 1-5: Daniel Senior Orifice Fitting sizes 2"-8" 900 (continued)

Item number	Description	Material	Quantity required				
			Size				
			2"	3"	4"	6"	8"
41	Stuffing box sleeve (lower)	CS (ZP)	4	4	4	4	4
42*	Plate carrier stop pin	CS (ZP)	1	1	1	1	1
43*	Plate carrier stop pin lock screw	CS (ZP)	1	1	1	1	1
44*	Plate carrier stop pin access plug	CS (ZP)	1	1	1	1	1
	Slide valve lubricant (boxes)	Castor oil based solid sticks - 24 sticks per box	3	3	3	3	3

Notes for Table 1-5:

(1) All Daniel Senior Orifice Fittings are supplied with pipe plugs on the drains only. If pipe plugs for the measurement tap holes are required, please contact the factory directly.

- Locations of Equalizer Valve (1), Bleeder Valve (10B), and Grease Gun (23) may differ from diagrams shown in this manual.
- The clamping bar screw quantity and size listed here reflect ones used on our most common fitting for that size and pressure rating. The actual number and size of clamping bar screws may vary for that size and pressure rating due to a fitting's material of construction and configuration. When ordering replacements, or developing a maintenance program, always confirm the count and size of clamping bar screws of your fitting.
- Slide Valve Lubricant: 0.38 in (9.53 mm) diameter by 1.5 in (38.1 mm) long is equivalent to some lubricant manufacturers' "B" size stick. The quantity of lubricant a fitting described in this manual will require is dependent upon the state and condition of the fitting. Emerson recommends having one box of lubricant sticks (24 sticks per box) on-hand when performing maintenance and plate inspection/change procedures.

(*) Indicates interchangeable parts for all line sizes of specified pressure rating(s).

(¹) Indicates 1/2" - 13. See Clamping bar screw (LINK) for clamping bar screw recommended torque values.

(²) Indicates 5/8" - 11. See Clamping bar screw (LINK) for clamping bar screw recommended torque values.

General notes for Table 1-5:

- The materials listed in Table 1-5 indicate standard "A" trim.
- Materials of some items listed in Table 1-5 are changed for "NACE" and "AASG" trimmed fittings.
- Several available trim options are shown in Table 1-3.
- Other trim options available upon request. Consult factory.

- Bolded item numbers are for parts which are fluid media PIC (parts in contact).

When ordering parts, please specify ⁽²⁾

- Catalog number
- Size
- Serial number
- Item number
- Material
- Quantity of each item required

⁽²⁾ *Catalog number, size and serial number can be found on the fitting nameplate. Part item numbers and part materials for "A" trim only are found in [Table 1-5](#).*

1.5.3 Daniel Senior Orifice Fitting sizes 10"-16" 150-900

Figure 1-3: Daniel Senior Orifice Fitting drawing sizes 10"-16" 150-900

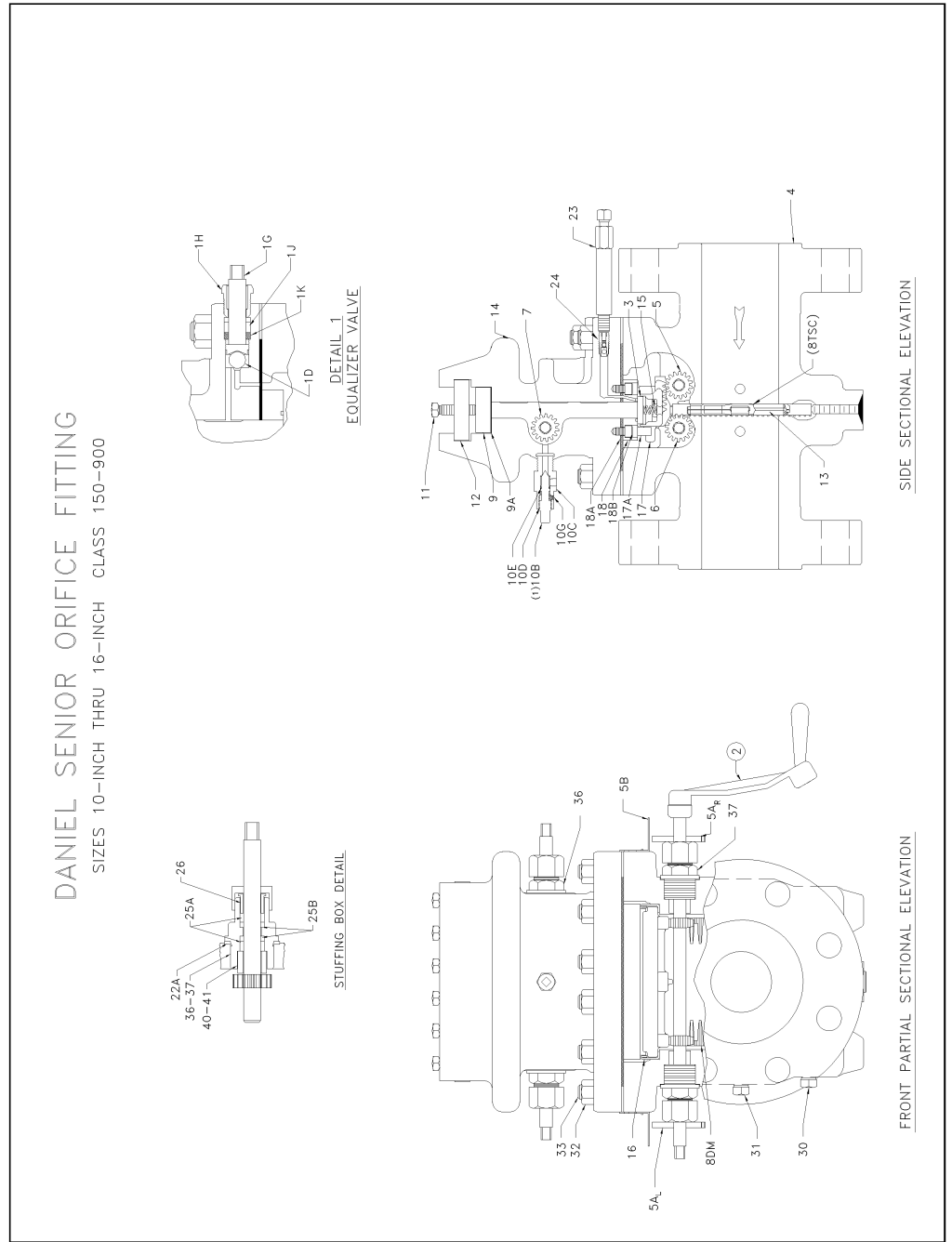

All Parts on Daniel Senior Orifice Fittings may be replaced or repaired without removing the Daniel Senior Orifice Fitting body from the line.

Table 1-6: Daniel Senior Orifice Fitting sizes 10"-16" 150-900

Item Number	Description	Material	Quantity required			
			Size			
			10"	12"	14"	16"
1*	Equalizer valve (complete):					
1G*	Stem	316 SS	1	1	1	1
1H*	Packing nut	CS (ZP)	1	1	1	1
1D*	Ball	18-8 SS	1	1	1	1
1K*	Packing washer	17-4PH SS	1	1	1	1
1J*	Packing ring	TFE/PTFE	2	2	2	2
2*	Operating wrench	Ductile iron	1	1	1	2
3	Slide valve trip	Type 410 SS	1	1	1	1
4	Body	Cast carbon steel	1	1	1	1
5	Slide valve shaft	316 SS	1	1	1	1
5A-LH*	Indicator plate left-hand	Cast aluminum	1	1	1	1
5A-RH	Indicator plate right-hand	Cast aluminum	1	1	1	1
5B*	Indicator pointer	Aluminum	2	2	2	2
5C	Drive screws	18-8 SS	4	4	4	4
6	Lower plate carrier shaft	316 SS	1	1	1	1
7	Upper plate carrier shaft	316 SS	1	1	1	1
8DM	Plate carrier	316 SS	1	1	1	1
8E-DS	Orifice plate sealing unit 150-600	NBR (Removable - orifice plate not included)	1	-	-	-
8E-DVS	Orifice plate sealing unit 150-600	FKM (Bonded to both faces of the orifice plate)	-	1	1	1
8TS	Orifice plate sealing unit 150-600, 900 optional alternate for 150-600	TFE/PTFE (removable)	1	1	1	1
8MS	Optional sealing units for special services	CS (ZP) or 316 SS (Removable - orifice plate not included)	1	1	1	1
8SN	Optional snap seal ring units for special services	CS (ZP) or 316 SS w/O-rings (Removable - orifice plate not included)	1	1	1	1

Table 1-6: Daniel Senior Orifice Fitting sizes 10"-16" 150-900 (continued)

Item Number	Description	Material		Quantity required			
				Size			
				10"	12"	14"	16"
9	Sealing bar	CS (ZP)		1	1	1	1
9A	Sealing bar gasket	Composite		1	1	1	1
10B*	Bleeder valve (Complete 10" - 14" only):			1	1	1	-
10C*	Body	CS (ZP)		1	1	1	-
10D*	Needle	316 SS		1	1	1	-
10E*	O-ring	Synthetic rubber		1	1	1	-
10G*	Set screw	Alloy steel		1	1	1	-
10F	Bleeder valve (Complete)	CS (ZP) w/410 SS		-	-	-	1
10H	Bleeder valve nipple			-	-	-	1
11*	Clamping bar screw	Alloy steel (ZP)	150-600	8 ⁽¹⁾	10 ⁽¹⁾	11 ⁽¹⁾	12 ⁽¹⁾
			900	8 ⁽²⁾	10 ⁽²⁾	22 ⁽²⁾	28 ⁽²⁾
12	Clamping bar	CS (ZP)		1	1	1	1
13	Orifice Plate	Type 304 SS or 316 SS		1	1	1	1
14	Top	Cast Carbon steel		1	1	1	1
15*	Slide valve springs	316 SS		6	7	8	10
16*	Slide valve carrier guide	316 SS		2	2	2	2
17	Slide valve carrier	Cast Carbon Steel		1	1	1	1
17A*	Slide valve carrier stop pin	CS (ZP)		2	2	2	2
18	Slide valve seat	Cast Alloy Iron	150-600	1	1	1	1
		TY 410 SS	900	1	-	-	-
		17-4PH SS	900	-	1	1	1
18A	Slide valve seat/top gasket	Composite		1	1	1	1
18B*	Slide valve seat screw	Alloy Steel Phosphate treat		18	20	24	26
22A*	Bearing Plug and stuffing box gasket	316 SS		6	6	6	6
23*	Grease gun (Complete)	CS (ZP)		1	1	1	2

Table 1-6: Daniel Senior Orifice Fitting sizes 10"-16" 150-900 (continued)

Item Number	Description	Material	Quantity required			
			Size			
			10"	12"	14"	16"
24*	Grease seal double ball check valve	316 SS with chrome-steel balls	1	1	1	2
25*	Packing Nut	CS (ZP)	6	6	6	6
25A*	Packing Rings	TFE/PTFE	12	12	12	12
25B*	Centering ring	TFE/PTFE	12	12	12	12
26*	Stuffing box gland	316 SS	6	6	6	6
30(1)*	Drain Valve plug	CS (ZP)	1	1	1	1
31(1)*	½ NPT Plug for pressure meter tap	CS (chemically treated)	2	2	2	2
32	Hex nut	CS	22	22	24	28
33	Stud	Alloy steel	22	22	24	28
36*	Stuffing box body (upper)	CS (ZP)	2	2	2	2
37*	Stuffing box body (lower)	CS (ZP)	4	4	4	4
40	Stuffing box sleeve (upper)	CS (ZP)	2	2	2	2
41	Stuffing box sleeve (lower)	CS (ZP)	4	4	4	4
	Slide valve lubricant (boxes)	Castor oil based solid sticks - 24 sticks per box	3	3	3	3

Notes for Daniel Senior Orifice Fitting sizes 10"-16" 150-900

(1) All Daniel Senior Orifice Fittings are supplied with pipe plugs on the drains only. If pipe plugs for the measurement tap holes are required, please contact the factory directly.

- Locations of Equalizer Valve (1), Bleeder Valve (10B), and Grease Gun (23) may differ from diagrams shown in this manual.
- The clamping bar screw quantity and size listed here reflect ones used on our most common fitting for that size and pressure rating. The actual number and size of clamping bar screws may vary for that size and pressure rating due to a fitting's material of construction and configuration. When ordering replacements, or developing a maintenance program, always confirm the count and size of clamping bar screws of your fitting.
- Slide Valve Lubricant: 0.38 in (9.53 mm) diameter by 1.5 in (38.1 mm) long is equivalent to some lubricant manufacturers' "B" size stick. The quantity of lubricant a fitting described in this manual will require is dependent upon the state and condition of the fitting. Emerson recommends having one box of lubricant sticks (24 sticks per box) on-hand when performing maintenance and plate inspection/change procedures.

(*) Indicates interchangeable parts for all line sizes of specified pressure rating(s).

(1) Indicates 1/2" - 13. See Clamping bar screw (LINK) for clamping bar screw recommended torque values.

(2) Indicates 5/8" - 11. See Clamping bar screw (LINK) for clamping bar screw recommended torque values.

General notes Daniel Senior Orifice Fitting sizes 10"-16" 150-900:

- The materials listed in [Daniel Senior Orifice Fitting sizes 10"-16" 150-900](#) indicate standard "A" trim.
- Materials of some items listed in [Daniel Senior Orifice Fitting sizes 10"-16" 150-900](#) are changed for "NACE" and "AASG" trimmed fittings.
- Several available trim options are shown in [Table 1-3](#).
- Other trim options available upon request. Consult factory.
- Bolded part numbers are for items which are fluid media PIC (parts in contact).

When ordering parts, please specify ⁽³⁾

- Catalog number
- Size
- Serial number
- Item number
- Material
- Quantity of each item required

(3) *Catalog number, size and serial number can be found on the fitting nameplate. Part item numbers and part materials for "A" trim only are found in [Daniel Senior Orifice Fitting sizes 10"-16" 150-900](#).*

1.5.4 Daniel Senior Orifice Fitting sizes 2"-8" 1500 and 2"-6" 2500

Figure 1-4: Daniel Senior Orifice Fitting drawing sizes 2"-8" 1500 and 2"-6" 2500

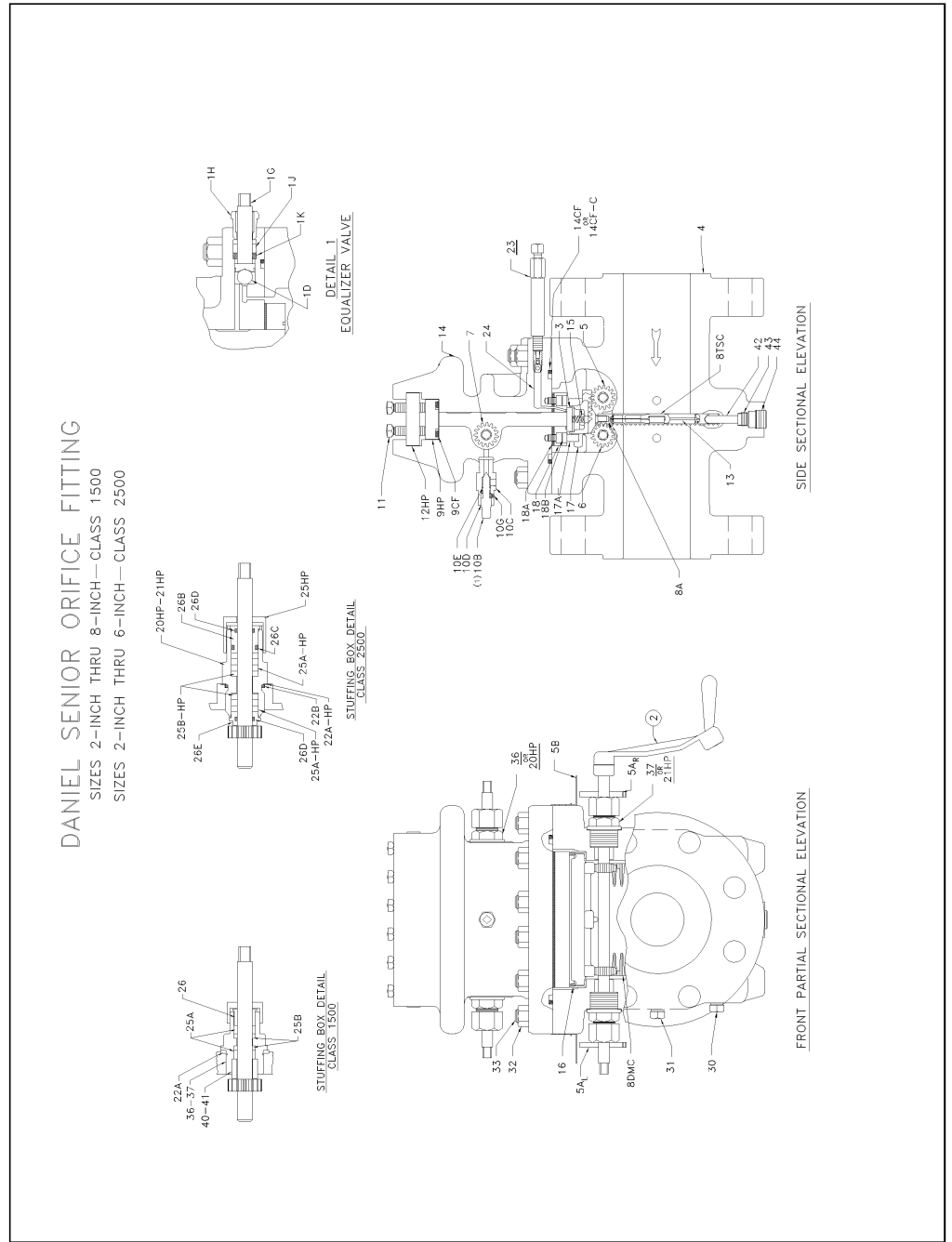

All Parts on Daniel Senior Orifice Fittings may be replaced or repaired without removing the Daniel Senior Orifice Fitting body from the line.

Table 1-7: Daniel Senior Orifice Fitting sizes 2" - 8" 1500 and 2"-6" 2500

Item number	Description	Material		Quantity required				
				Size				
				2"	3"	4"	6"	8"
1	Equalizer valve (complete):							
1G*	Stem	316 SS	1	1	1	1	1	
1H*	Packing nut	CS (ZP)	1	1	1	1	1	
1D*	Ball	18-8 SS	1	1	1	1	1	
1K*	Packing washer	17-4PH SS	1	1	1	1	1	
1J*	Packing ring	TTFE/PTFE	2	2	2	2	2	
2*	Operating wrench	Ductile iron	1	1	1	1	1	
3	Slide valve strip	Type 410 SS	1	1	1	1	1	
4	Body	Cast carbon steel	1	1	1	1	1	
5	Slide valve shaft	316 SS	1	1	1	1	1	
5A-LH*	Indicator plate left-hand	Cast aluminum	1	1	1	1	1	
5A-RH	Indicator plate right-hand	Cast aluminum	1	1	1	1	1	
5B*	Indicator pointer	Aluminum	2	2	2	2	2	
5C	Drive screws	18-8 SS	4	4	4	4	4	
6	Lower plate carrier shaft	316 SS	1	1	1	1	1	
7	Upper plate carrier shaft	316 SS	1	1	1	1	1	
8A*	Plate carrier spring pin	18-8 SS	1	1	1	1	1	
8DMC	Plate carrier	316 SS	1500	1	1	1	1	1
			2500	-	-	-	1	-
		CS (ZP)	2500	1	1	1	-	-
8TSC	Orifice plate sealing unit	TTFE/PTFE (Removable - orifice plate not included)		1	1	1	1	1
8 MSC	Optional Snap Seal Ring units for special services	CS (ZP) or 316 SS (Removable - orifice plate not included)		1	1	1	1	1
8 SNC	Optional Snap Seal Ring units for special services	CS (ZP) or 316 SS w/O-rings (Removable - orifice plate not included)		1	1	1	1	1
9-HP	Sealing Bar	CS (ZP)		1	1	1	1	1
9A-CF	Sealing Bar Gasket (O-ring)	Synthetic rubber		1	1	1	1	1

Table 1-7: Daniel Senior Orifice Fitting sizes 2" - 8" 1500 and 2"-6" 2500 (continued)

Item number	Description	Material		Quantity required				
				Size				
				2"	3"	4"	6"	8"
10B*	Bleeder valve (complete):							
10C*	Body	CS (ZP)		1	1	1	1	1
10D*	Needle	316 SS		1	1	1	1	1
10E*	O-ring	Synthetic rubber		1	1	1	1	1
10G*	Set screw	Alloy steel		1	1	1	1	1
11*	Clamping bar screw (See Note 3 in NOTES for this table)	Alloy steel (ZP)	1500	8 ⁽²⁾	10 ⁽²⁾	12 ⁽²⁾	14 ⁽²⁾	16 ⁽²⁾
			2500	10 ⁽²⁾	10 ⁽²⁾	12 ⁽²⁾	14 ⁽²⁾	-
12HP	Clamping bar	CS (ZP)		1	1	1	1	1
13	Orifice plate	Type 304 SS or 316 SS		1	1	1	1	1
14	Top	Cast carbon steel		1	1	1	1	1
14CF	Body-top gasket ("o-ring)	Special compound	1500	1	1	1	1	1
14CF-C	Body-top gasket (Male-Female Joint) Not illustrated	Synthetic Rubber	2500	1	1	1	1	-
15*	Slide valve springs	316 SS		4	4	4	6	6
16*	Slide valve carrier guide	316 SS		2	2	2	2	2
17	Slide valve carrier	Cast carbon steel		1	1	1	1	-
		Cast Alloy Iron		-	-	-	-	1
17A*	Slide valve carrier stop pin	Carbon steel (ZP)		2	2	2	2	2
18	Slide valve seat	13% chrome SS		1	1	1	1	1
18A	Slide valve seat/top gasket	Composite	1500	1	1	1	1	1
			2500	Assembled metal-to-metal				
18B*	Slide valve seat screw	Alloy steel phosphate treat	1500	8	10	11	14	16
			2500	10	10	11	14	12
20 HP	Stuffing Box (Upper)	CS (ZP)	2500	2	2	2	2	0
21 HP	Stuffing Box (Lower)	CS (ZP)	2500	4	4	4	4	0
22A*	Bearing plug and stuffing box gasket	316 SS	1500	6	6	6	6	6
22A -HP*	Bearing plug and stuffing box gasket	316 SS	2500	6	6	6	6	-
22B*	Bearing plug and stuffing box O-ring	Synthetic rubber	2500	6	6	6	6	-

Table 1-7: Daniel Senior Orifice Fitting sizes 2" - 8" 1500 and 2"-6" 2500 (continued)

Item number	Description	Material		Quantity required				
				Size				
				2"	3"	4"	6"	8"
23*	Grease gun (complete)	CS (ZP)		1	1	1	1	1
24*	Grease seal double ball check valve	316 SS with chrome-steel balls		1	1	1	1	1
25*	Packing nut	CS (ZP)	1500	6	6	6	6	6
25HP*	Packing nut	CS (ZP)	2500	6	6	6	6	6
25A*	Packing rings	TTFE/PTFE	1500	12	12	12	12	12
25A-HP*	Packing rings	TTFE/PTFE	2500	Varies with fitting size				
25B*	Centering ring	TTFE/PTFE	1500	12	12	12	12	12
25B-HP*	Centering ring	TTFE/PTFE	2500	12	12	12	12	-
26*	Stuffing box gland	316 SS	1500	6	6	6	6	6
26B*	External Stuffing box gland	316 SS	2500	6	6	6	6	-
26E*	Internal Stuffing box gland	316 SS	2500	6	6	6	6	-
26C*	Stuffing box gland O-ring	Synthetic rubber	2500	6	6	6	6	-
26D*	Stuffing box gland O-ring	Synthetic rubber	2500	12	12	12	12	-
30(1)*	Drain valve plug	CS (ZP)		1	1	1	1	1
31(1)*	½ N.P.T. plug for pressure meter tap	CS (chemically treated)		2	2	2	2	2
32	Hex nut	CS	1500	14	14	16	18	18
			2500	16	16	16	18	-
33	Stud	Alloy steel	1500	14	14	16	18	18
			2500	16	16	16	18	-
36*	Stuffing box (upper)	CS (ZP)	1500	2	2	2	2	2
37*	Stuffing box (lower)	CS (ZP)	1500	4	4	4	4	4
40	Stuffing box sleeve (upper)	CS (ZP)	1500	2	2	2	2	2
41	Stuffing box sleeve (lower)	CS (ZP)	1500	4	4	4	4	4
42*	Plate carrier stop pin	CS (ZP)		1	1	1	1	1
43*	Plate carrier stop pin lock screw	CS (ZP)		1	1	1	1	1

Table 1-7: Daniel Senior Orifice Fitting sizes 2"- 8" 1500 and 2"-6" 2500 (continued)

Item number	Description	Material	Quantity required				
			Size				
			2"	3"	4"	6"	8"
44*	Plate carrier stop pin access plug	CS (ZP)	1	1	1	1	1
	Slide valve lubricant (boxes)	Castor oil based solid sticks - 24 sticks per box	3	3	3	3	3

Notes for Daniel Senior Orifice Fitting sizes 2"-8" 1500 and 2"-6" 2500

(1) All Daniel Senior Orifice Fittings are supplied with pipe plugs on the drains only. If pipe plugs for the measurement tap holes are required, please contact the factory directly.

- Locations of Equalizer Valve (1), Bleeder Valve (10B), and Grease Gun (23) may differ from diagrams shown in this manual.
- The clamping bar screw quantity and size listed here reflect ones used on our most common fitting for that size and pressure rating. The actual number and size of clamping bar screws may vary for that size and pressure rating due to a fitting's material of construction and configuration. When ordering replacements, or developing a maintenance program, always confirm the count and size of clamping bar screws of your fitting.
- Slide Valve Lubricant: 0.38 in (9.53 mm) diameter by 1.5 in (38.1 mm) long is equivalent to some lubricant manufacturers' "B" size stick. The quantity of lubricant a fitting described in this manual will require is dependent upon the state and condition of the fitting. Emerson recommends having one box of lubricant sticks (24 sticks per box) on-hand when performing maintenance and plate inspection/change procedures.

(*) Indicates interchangeable parts for all line sizes of specified pressure rating(s).

(²) Indicates 5/8" - 11. See Clamping bar screw (LINK) for clamping bar screw recommended torque values.

General notes for Daniel Senior Orifice Fitting sizes 2"-8" 1500 and 2"-6" 2500

- Most parts available in other materials upon customer request.
- CS (Carbon Steel), CRS (Cold Rolled Steel), NPT (National Pipe Thread), ZP (Zinc Plated).
- The materials listed in [Daniel Senior Orifice Fitting sizes 2"-8" 1500 and 2"-6" 2500](#) indicate standard "A" trim.
- Materials of some items listed in [Daniel Senior Orifice Fitting sizes 2"-8" 1500 and 2"-6" 2500](#) are changed for "NACE" and "AASG" trimmed fittings.
- Several available trim options are shown in [Table 1-3](#).
- Other trim options available upon request. Consult factory.
- Bolded part numbers are for items which are fluid media PIC (parts in contact).

When ordering parts, please specify ⁽⁴⁾

- Catalog number
- Size
- Serial number
- Item number
- Material
- Quantity of each item required

(4) Catalog number, size and serial number can be found on the fitting nameplate. Part item numbers and part materials for "A" trim only are found in Daniel Senior Orifice Fitting sizes 2"-8" 1500 and 2"-6" 2500.

1.5.5 Daniel Senior Orifice Fitting sizes 10"- 16" 1500

Figure 1-5: Daniel Senior Orifice Fitting drawing sizes 10"- 16" 1500

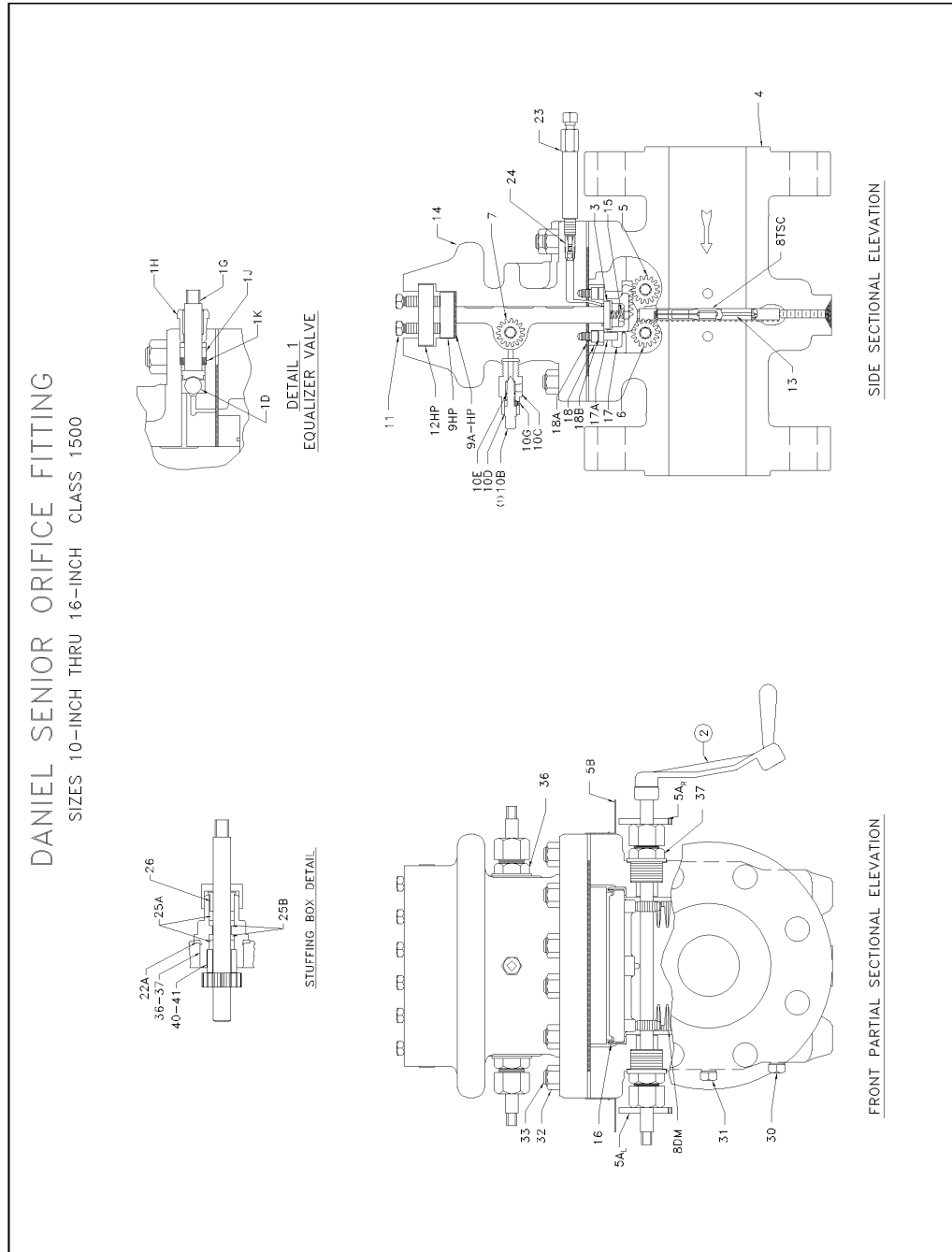

All Parts on Daniel Senior Orifice Fittings may be replaced or repaired without removing the Daniel Senior Orifice Fitting body from the line.

Table 1-8: Daniel Senior Orifice Fitting sizes 10"- 16" 1500

Item Number	Description	Material	Quantity required			
			Size			
			10"	12"	14"	16"
1*	Equalizer valve (complete):					
1G*	Stem	316 SS	1	1	1	1
1H*	Packing nut	CS (ZP)	1	1	1	1
1D*	Ball	18-8 SS	1	1	1	1
1K*	Packing washer	17-4PH SS	1	1	1	1
1J*	Packing ring	TFE/PTFE	2	2	2	2
2*	Operating wrench	Ductile iron	1	1	1	2
3	Slide valve trip	Type 410 SS	1	1	1	1
4	Body	Cast carbon steel	1	1	1	1
5	Slide valve shaft	316 SS	1	1	1	1
5A-LH*	Indicator plate left-hand	Cast aluminum	1	1	1	1
5A-RH	Indicator plate right-hand	Cast aluminum	1	1	1	1
5B*	Indicator pointer	Aluminum	2	2	2	2
5C	Drive screws	18-8 SS	4	4	4	4
6	Lower plate carrier shaft	316 SS	1	1	1	1
7	Upper plate carrier shaft	316 SS	1	1	1	1
8DM	Plate carrier	316 SS	1	1	1	1
8TS	Orifice plate sealing unit	TFE/PTFE (Removable - orifice plate not included)	1	1	1	1
8MS	Optional sealing units for special services	CS (ZP) or 316 SS (Removable - orifice plate w/O-rings not included)	1	1	1	1
8SN	Optional snap seal ring units for special services	CS (ZP) or 316 SS (Removable - orifice plate w/O-rings not included)	1	1	1	1
9HP	Sealing bar	CS (ZP)	1	1	1	1
9A-HP	Sealing bar gasket	Composite	1	1	1	1
10B*	Bleeder valve (Complete)		1	1	1	-
10C*	Body	CS (ZP)	1	1	1	-
10D*	Needle	316 SS	1	1	1	-

Table 1-8: Daniel Senior Orifice Fitting sizes 10"- 16" 1500 (continued)

Item Number	Description	Material	Quantity required			
			Size			
			10"	12"	14"	16"
10E*	O-ring	Synthetic rubber	1	1	1	-
10G*	Set screw	Alloy steel	1	1	1	-
10F	Bleeder valve (Complete)	CS (ZP) w/410 SS	-	-	-	1
10H	Bleeder valve nipple	CS (ZP)	-	-	-	1
11*	Clamping bar screw	Alloy steel (ZP)	20 ⁽²⁾	22 ⁽²⁾	22 ⁽²⁾	28 ⁽²⁾
12HP	Clamping bar	CS (ZP)	1	1	1	1
13	Orifice Plate	Type 304 SS or 316 SS	1	1	1	1
14	Top	Cast Carbon steel	1	1	1	1
15*	Slide valve springs	316 SS	6	7	8	10
16*	Slide valve carrier guide	316 SS	2	2	2	2
17	Slide valve carrier	Cast Carbon Steel	1	1	1	1
17A*	Slide valve carrier stop pin	Carbon steel	2	2	2	2
18	Slide valve seat	Type 410 SS	1	-	-	-
		17-4PH SS	-	1	1	-
		Duplex SS (UNS S31803)	-	-	-	1
18A	Slide valve seat/top gasket	Composite	1	1	1	1
18VSG	Slide valve seat gasket	Composite (not shown)	-	-	1	1
18BTG	Body/top gasket	Composite (not shown)	-	-	1	1
18B*	Slide valve seat screw	Alloy Steel Phosphate treat	18	20	24	26
22A*	Bearing Plug and stuffing box gasket	316 SS	6	6	6	6
23*	Grease gun (Complete)	CS (ZP)	1	1	1	2
24*	Grease seal double ball check valve	316 SS with chrome-steel balls	1	1	1	2
25*	Packing Nut	CS (ZP)	6	6	6	6
25A*	Packing Rings	TFE/PTFE	12	12	12	12
25B*	Centering ring	TFE/PTFE	12	12	12	12
26*	Stuffing box gland	316 SS	6	6	6	6
30(1)*	Drain Valve plug	CS (ZP)	1	1	1	1
31(1)*	½ NPT Plug for pressure meter tap	CS (chemically treated)	2	2	2	2

Table 1-8: Daniel Senior Orifice Fitting sizes 10" - 16" 1500 (continued)

Item Number	Description	Material	Quantity required			
			Size			
			10"	12"	14"	16"
32	Hex nut	CS	22	22	28	32
33	Stud	Alloy steel	22	22	28	32
36*	Stuffing box body (upper)	CS (ZP)	2	2	2	2
37*	Stuffing box body (lower)	CS (ZP)	4	4	4	4
40	Stuffing box sleeve (upper)	CS (ZP)	2	2	2	2
41	Stuffing box sleeve (lower)	CS (ZP)	4	4	4	4
	Slide valve lubricant (boxes)	Castor Oil based solid sticks - 24 sticks per box	3	3	3	3

Notes for Daniel Senior Orifice Fitting sizes 10" - 16" 1500

(1) All Daniel Senior Orifice Fittings are supplied with pipe plugs on the drains only. If pipe plugs for the measurement tap holes are required, please contact the factory directly.

- Locations of Equalizer Valve (1), Bleeder Valve (10B), and Grease Gun (23) may differ from diagrams shown in this manual.
- The clamping bar screw quantity and size listed here reflect ones used on our most common fitting for that size and pressure rating. The actual number and size of clamping bar screws may vary for that size and pressure rating due to a fitting's material of construction and configuration. When ordering replacements, or developing a maintenance program, always confirm the count and size of clamping bar screws of your fitting.
- Slide Valve Lubricant: 0.38 in (9.53 mm) diameter by 1.5 in (38.1 mm) long is equivalent to some lubricant manufacturers' "B" size stick. The quantity of lubricant a fitting described in this manual will require is dependent upon the state and condition of the fitting. Emerson recommends having one box of lubricant sticks (24 sticks per box) on-hand when performing maintenance and plate inspection/change procedures.

(*) Indicates interchangeable parts for all line sizes of specified pressure rating(s).

(²) Indicates 5/8" - 11. See Clamping bar screw (LINK) for clamping bar screw recommended torque values.

General notes for Daniel Senior Orifice Fitting sizes 10" - 16" 1500:

- The materials listed in Daniel Senior Orifice Fitting sizes 10" - 16" 1500 indicate standard "A" trim.
- Materials of some items listed in Daniel Senior Orifice Fitting sizes 10" - 16" 1500 are changed for "NACE" and "AASC" trimmed fittings.
- Several available trim options are shown in Table 1-3.

- Other trim options available upon request. Consult factory.
- Bolded part numbers are for items which are fluid media PIC (parts in contact).

When ordering parts, please specify ⁽⁵⁾

- Catalog number
- Size
- Serial number
- Item number
- Material
- Quantity of each item required

⁽⁵⁾ *Catalog number, size and serial number can be found on the fitting nameplate. Part item numbers and part materials for "A" trim only are found in Daniel Senior Orifice Fitting sizes 10"- 16" 1500.*

1.5.6 Daniel Senior Orifice Fitting sizes 8"-12" 2500

Figure 1-6: Daniel Senior orifice Fitting drawing sizes 8" - 12" 2500

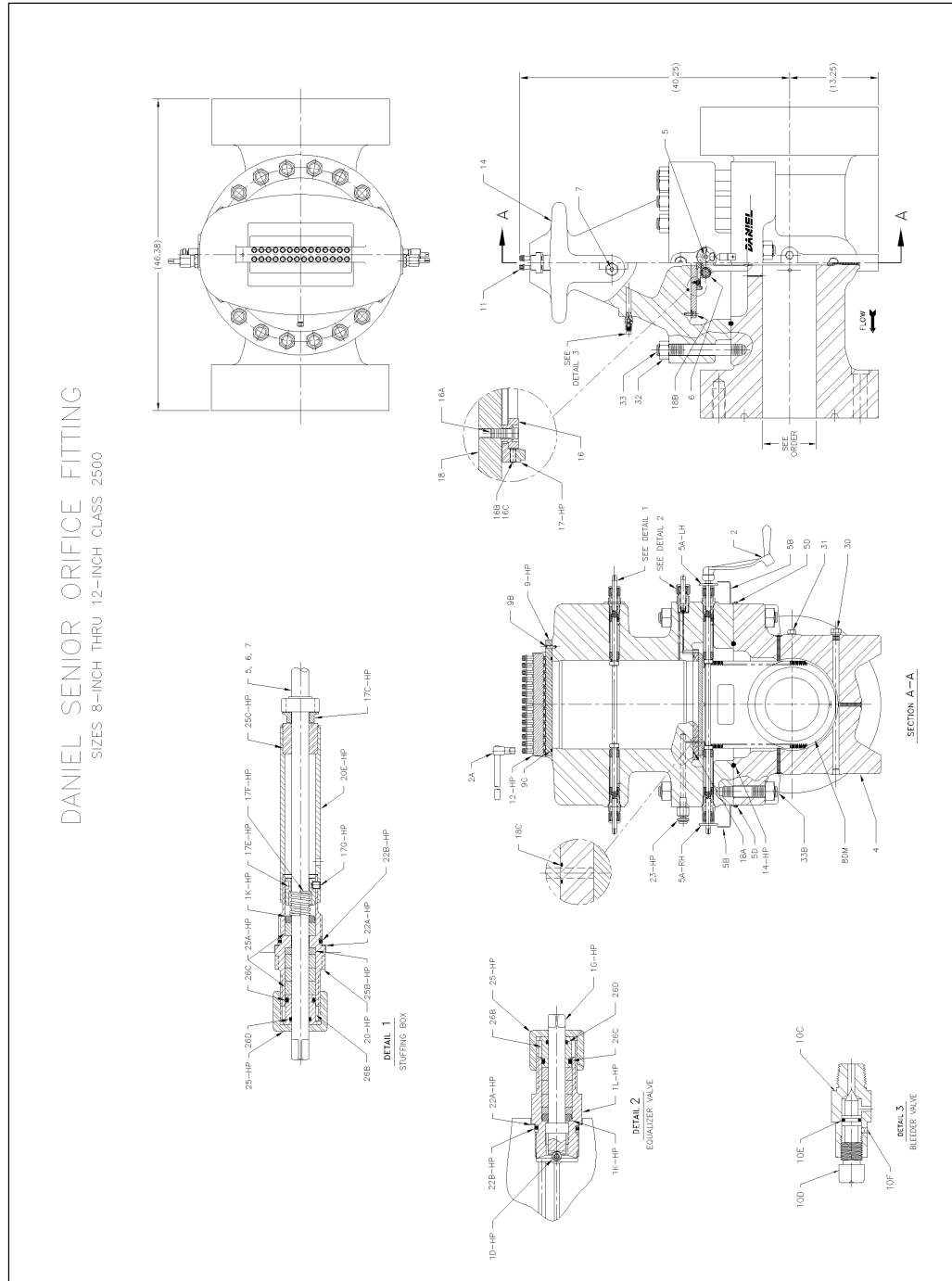

All Parts on Daniel Senior Orifice Fittings may be replaced or repaired without removing the Daniel Senior Orifice Fitting body from the line.

Table 1-9: Daniel Senior Orifice Fitting sizes 8"-12" 2500

Item number	Description	Material	Quantity required		
			Size		
			8"	10"	12"
1D-HP	Equalizer valve ball	18-8 SS	1	1	1
1G-HP	Equalizer valve stem	316 SS	1	1	1
1K-HP	Equalizer valve washer	316 SS	7	7	7
1L-HP	Equalizer valve stuffing box	CS	1	1	1
*2	Operating wrench - gear shafts	Ductile iron	1	1	1
2A	Operating wrench - clamping bar screws	Alloy steel	1	1	1
4	RTJ-FI body	Cast steel	1	1	1
*5A-LH	Indicator plate left-hand	Aluminum	1	1	1
*5A-RH	Indicator plate right-hand	Aluminum	1	1	1
5B	Indicator pointer	Aluminum	2	2	2
5D	Indicator pointer attachment screw	316 SS	2	2	2
5, 6, 7	Gear shaft	316 SS	3	3	3
8DM	Plate carrier	CS	1	1	1
8TSC/8TS	Orifice Plate Sealing Unit 1500-2500	TFE/PTFE (Removable - orifice plate not included) (8TSC /8"; 8TS /10"-12")	1	1	1
8MSC/8MS	Optional sealing units for special services	CS (ZP) or 316 SS w/O-rings (orifice plate not included) (8SNC /8"; 8SN /10"-12")	1	1	1
10C	Bleeder valve body	CS (ZP)	1	1	1
10D	Bleeder valve stem	316 SS	1	1	1
10E	Bleeder Valve Stem O-ring gasket	NBR	1	1	1
10F	SKTD HD set screw	Alloy steel	1	1	1
11	Clamping bar screw	Alloy steel (zinc plated)	26 ⁽²⁾	28 ⁽²⁾	28 ⁽²⁾
12-HP	Clamping bar	Carbon steel	1	1	1
13	Orifice plate	Type 304 SS or 316 SS	1	1	1
14	Top	Cast steel	1	1	1
14-HP	Body-top ring gasket	Soft iron	1	1	1
16	Slide valve guide	316 SS	2	2	2
*16A	Slide valve guide attachment screw	Alloy steel	2	2	2
16B	Slide valve adjustment screw	316 SS	2	2	2

Table 1-9: Daniel Senior Orifice Fitting sizes 8"-12" 2500 (continued)

Item number	Description	Material	Quantity required		
			Size		
			8"	10"	12"
16C	Slide valve lock screw	316 SS	2	2	2
17-HP	Slide valve	11-14% CHSS	1	1	1
17C-HP	Shaft spacer	316 SS	6	6	6
17E-HP	Stuffing box spring retainer	316 SS	6	6	6
17F-HP	Stuffing box spring	316 SS	6	6	6
17G-HP	Spring retainer set screw	316 SS	6	6	6
18	Valve seat	410 SS	1	1	1
18A	O-ring, valve seat gasket	NBR	1	1	1
*18B	Valve seat screw	Alloy steel	12	12	12
18C	O-ring, grease port (seat) gasket	NBR	1	1	1
20-HP	Stuffing box body	CS	6	6	6
20E-HP	Stuffing box extension	CS	6	6	6
22A-HP	Bearing plug and stuffing box gasket	316 SS	7	7	7
22B-HP	O-ring, stuffing box	NBR	7	7	7
23-HP	Grease fitting with #1 adapt.	Comm. item	1	1	1
25-HP	packing nut	CS	7	7	7
25A-HP	Shaft packing ½" LG	TFE/PTFE	27	27	27
25B-HP	Shaft packing ¼" LG	TFE/PTFE	6	6	6
25C-HP	Stuffing box bushing	TFE/PTFE	6	6	6
26B	External stuffing box gland	316 SS	7	7	7
26C	O-ring, stuffing box gland	NBR	7	7	7
26D	O-ring, stuffing box gland	NBR	7	7	7
30	Drain plug	CS	1	1	1
31	Meter tap plug	CS	2	2	2
32	Hex nut	Alloy steel	20	20	20
33	Body-top stud (long)	Alloy steel	16	16	16
33B	Body-top stud (short)	Alloy steel	4	4	4
*45	Senior ID plate (not shown)	304 SS	1	1	1
46-HP	Instruction plate (not shown)	304 SS	1	1	1
*47	Warning plate (not shown)	316 SS	1	1	1
BNP	Bleeder valve plate(not shown)	304 SS	1	1	1

Table 1-9: Daniel Senior Orifice Fitting sizes 8"-12" 2500 (continued)

Item number	Description	Material	Quantity required		
			Size		
			8"	10"	12"
ENP	Equalizer valve plate(not shown)	304 SS	1	1	1
GNP	Grease gun plate (not shown)	304 SS	1	1	1
	Slide valve lubricant - Bulk or stick as required	Castor oil based solid			

Notes for Daniel Senior Orifice Fitting sizes 8"-12" 2500

(1) All Daniel Senior Orifice Fittings are supplied with pipe plugs on the drains only. If pipe plugs for the measurement tap holes are required, please contact the factory directly.

- Locations of Equalizer Valve (1), Bleeder Valve (10B), and Grease Gun (23) may differ from diagrams shown in this manual.
- The clamping bar screw quantity and size listed here reflect ones used on our most common fitting for that size and pressure rating. The actual number and size of clamping bar screws may vary for that size and pressure rating due to a fitting's material of construction and configuration. When ordering replacements, or developing a maintenance program, always confirm the count and size of clamping bar screws of your fitting.
- Slide Valve Lubricant: 0.38 in (9.53 mm) diameter by 1.5 in (38.1 mm) long is equivalent to some lubricant manufacturers' "B" size stick. The quantity of lubricant a fitting described in this manual will require is dependent upon the state and condition of the fitting. Emerson recommends having one box of lubricant sticks (24 sticks per box) on-hand when performing maintenance and plate inspection/change procedures.

(*) Indicates interchangeable parts for all line sizes of specified pressure rating(s).

(²) Indicates 5/8" - 11. See Clamping bar screw (LINK) for clamping bar screw recommended torque values.

General notes for Daniel Senior Orifice Fitting sizes 8"-12" 2500:

- Most parts available in other materials upon customer request.
- CS (Carbon Steel), CRS (Cold Rolled Steel), NPT (National Pipe Thread), ZP (Zinc Plated).
- The materials listed in [Daniel Senior Orifice Fitting sizes 8"-12" 2500](#) indicate standard "A" trim.
- Materials of some items listed in [Daniel Senior Orifice Fitting sizes 8"-12" 2500](#) are changed for "NACE" and "AASG" trimmed fittings.
- Several available trim options are shown in [Table 1-3](#).
- Other trim options available upon request. Consult factory.
- Bolded part numbers are for items which are fluid media PIC (parts in contact).

When ordering parts, please specify ⁽⁶⁾

- Catalog number
- Size
- Serial number
- Item number
- Material
- Quantity of each item required

(6) Catalog number, size and serial number can be found on the fitting nameplate. Part item numbers and part materials for "A" trim only are found in Daniel Senior Orifice Fitting sizes 8"-12" 2500.

Part II

Install

2 General Information

2.1 Installation

Figure 2-1: Daniel Senior Orifice Fitting component identification

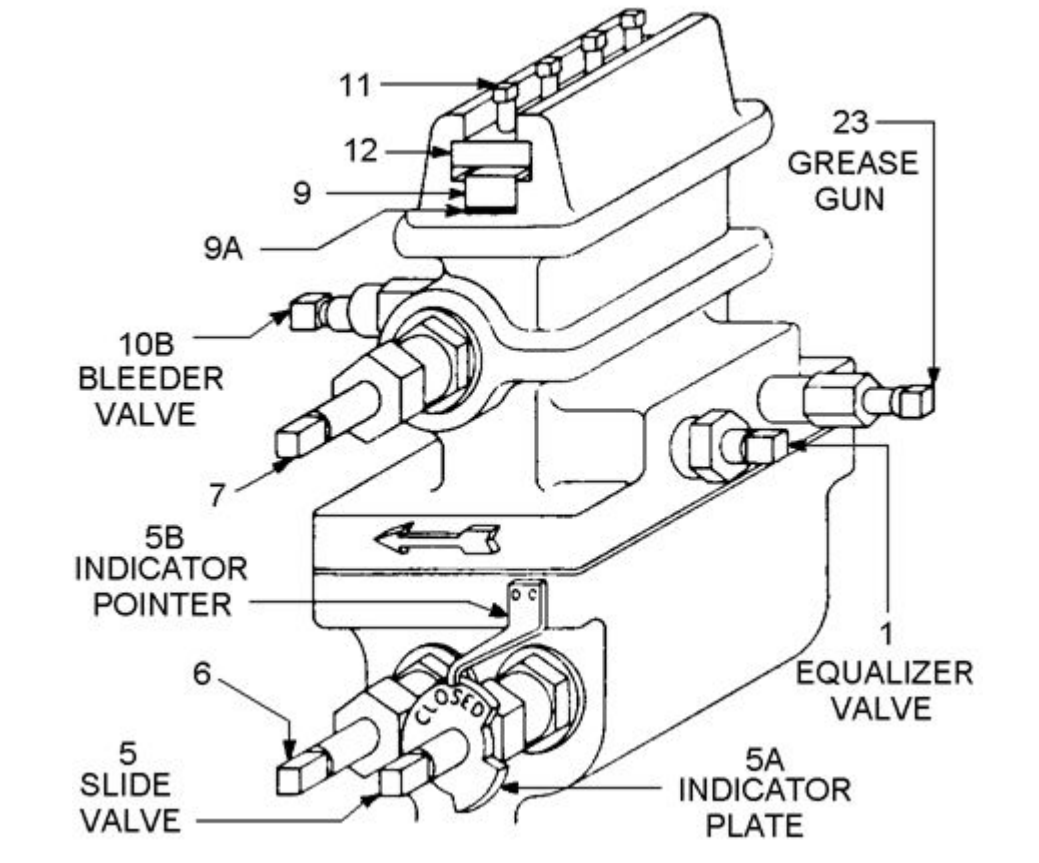

2.1.1 Information prior to installation

Figure 2-2: Daniel Senior Orifice Fitting component identification

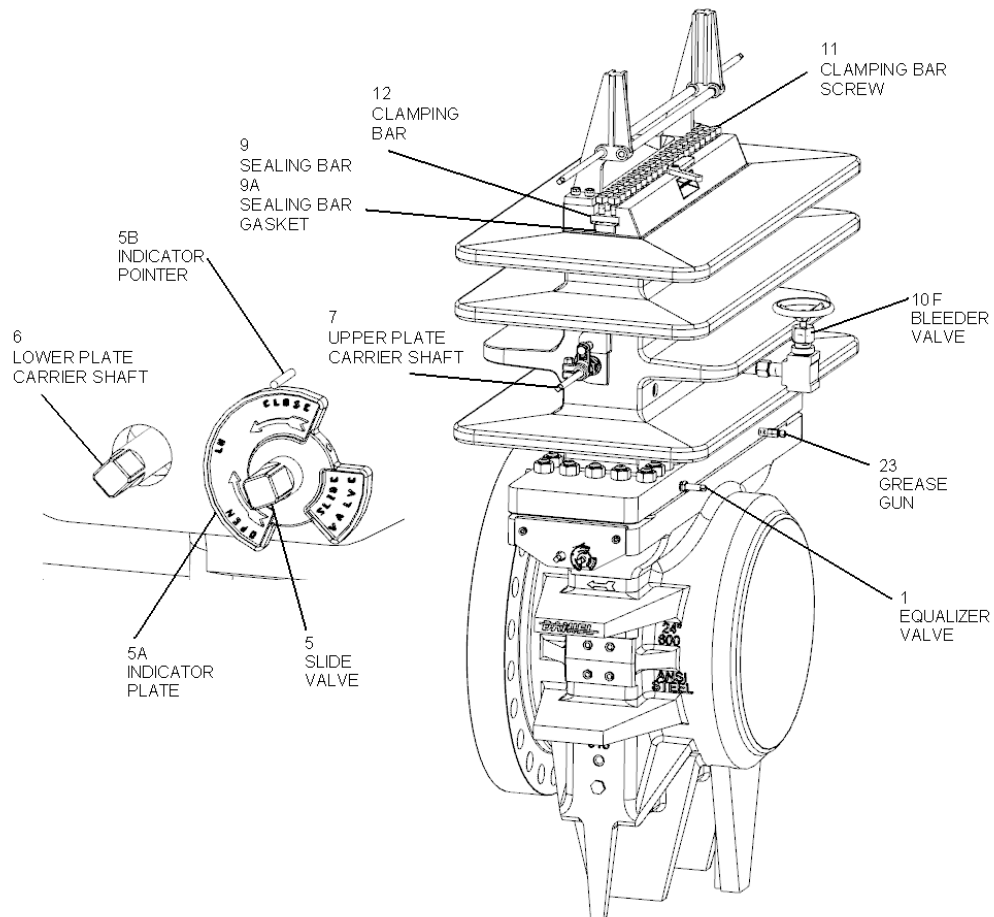

! WARNING

HIGH PRESSURE HAZARD

Follow all instructions provided in this section when installing the Sealing Bar Gasket (9A), Sealing Bar (9), and Clamping Bar (12).

Failure to comply may cause pressurized fluids to escape, resulting in death or serious injury.

The Daniel Senior Fitting is an essential element in any orifice measurement system. Other elements in an orifice measurement system may include a meter tube, a flow conditioner, and various data recording devices.

Purchasers have the option of acquiring only a Daniel Senior fitting unit for later installation in a flow measurement system, purchasing a Senior Orifice fitting with a meter tube, or purchasing a complete flow measurement system containing a Senior Orifice fitting.

At our factories, Emerson personnel perform two unique tests on each Senior fitting for fluid retention. The first test is an internal hydrostatic SHELL test on a full assembled TOP (14) and BODY (4) with the slide valve seat (18) open, to a minimum pressure of 1.5 times its rated maximum allowable operating pressure. The second test is an internal hydrostatic SEAT test. With the slide valve seat (18) closed, Emerson personnel apply a minimum pressure of 1.1 times the rated maximum allowable operating pressure to the BODY (4) only.

Important

When purchasing only a Daniel Senior fitting, it is the responsibility of the both the product owners and product operating personnel to perform an internal hydrostatic shell test of the final meter tube assembly prior to service.

Product owners and product operating personnel performing an internal hydrostatic SEAT test of the Daniel Senior fitting prior to service should not exceed 1.1 times its rated maximum allowable operating pressure within the BODY (4) and with the slide valve seat (18) closed.

 WARNING**FLUID EXPLOSION HAZARD**

Never pressurize a unit above the limits recommended in this manual. Before pressurizing the Daniel Senior Fitting, confirm the maximum allowable operating pressure (MAOP) of each item in the system.

Over-pressurizing the Daniel Senior fitting could lead to an explosive release of fluid resulting in death, serious injury or damage to the Senior.

When assembling a flow measurement system that will contain a Daniel Senior Orifice Fitting, particular attention should be paid to the requirements for permanent joining of components. This will be to ensure optimal measurement performance and successful pressure test results. Referencing an appropriate measurement code (API-14.3, ISO 5167, etc.) will aid in this assembly.

NOTICE

Follow all the safety and equipment limits recommended in [Conditions and specifications](#) of this manual.

It is the owner's and/or purchaser's responsibility to comply with these parameters.

NOTICE

On installations built to comply with the European Union Pressure Equipment Directive (PED) 2014/68/EU, it is the responsibility of the end user to meet all essential safety requirements of the directive (available on the internet).

End users must pay particular attention to the requirements for permanent joining and non-destructive testing. Refer to the "Daniel Orifice Fittings - Installation and Operating Instructions specific to the Pressure Equipment Directive", Part Number 3-9008-002 (available on the Daniel Flow website).

2.1.2 Storage

Follow your company's storage procedures when placing any measurement equipment into inventory. Spraying a light coat of rust inhibitor onto the inside bore of a Daniel Senior, and to the bore of the meter tube, may protect its surface finish during storage.

2.1.3 Preliminary Steps

NOTICE

Follow all the safety and equipment limits recommended in [Conditions and specifications](#) of this manual. It is the owner's and/or purchaser's responsibility to comply with these parameters.

The Senior may arrive at your site in any number of ways, usually as a component in a meter tube/measurement system, or as a loose fitting. If received as a loose fitting, then see the appropriate code (API-14.3, etc.) for assembly requirements.

It is the responsibility of the product operators to clean the Senior and all piping components of foreign matter such as welding debris, scale, oil, grease, and dirt before commissioning.

Record the serial plate data on the Senior's nameplate for future reference. Always provide the serial number and model number when ordering spare parts.

The factory places the plate carriers (8DMC or 8DM) inside the fitting for shipment.

The factory packages the Orifice Plates (13) and Seal Ring units (8E-DSC or 8E-DS; 8TSC or 8TS; 8MSC or 8MS; 8SNC or 8SN) separately from the fitting.

2.1.4 Severe service conditions

If product owner expects to encounter gas or liquid composition where there is a likelihood of sediment accumulation within the fitting, then Emerson recommends that the owner instruct their operators to remove Drain Valve Plug (30) and install a blow-down valve in its place.

2.1.5 Corrosive service

Corrosive environments may affect both the external and internal surfaces of the Senior. External corrosive environments are defined as those conditions that affect the outer surfaces of the Senior, while an internal corrosive environment is a condition that affects the surface inside the Senior. Read, understand, and follow instructions in the sections below if an internal or external corrosive environment exists.

External corrosive environments

For Seniors located in external corrosive environments (offshore platforms, marine terminals, etc), Emerson recommends replacing the standard carbon steel Equalizer Valve (Complete) (1), Bleeder Valve (Complete) (10B), Grease Gun (Complete) (23) and Drain Valve Plug (30) with the stainless steel versions listed in the "Corrosive Service" column (refer to [Low temperature service](#)).

Internal corrosive environments

It is the end user's responsibility to specify a fitting's material of construction based upon their knowledge of the process fluid and environmental conditions of an intended application. A number of trim packages are available for severe service to improve durability of the Senior fitting (Refer to [Table 1-3](#)).

The inside diameter specifications of a Senior fitting are exact. No allowance is provided for corrosion of the inside diameter.

2.1.6 Low temperature service

The fitting's material of construction is just one factor to consider when placing an orifice fitting into a low temperature service. Other factors to consider are the temperature characteristics of the slide valve lubricant, and the temperature limitations of the orifice plate seal material.

Operating temperatures have an effect on all valve lubricant Emerson offers. Lower temperatures increase a valve lubricant's viscosity. Higher viscosity lubricant is more difficult to transfer from the grease gun, through the grease channels and to the slide valve. Additionally the application of a high viscosity lubricant into a Daniel fitting may result in an uneven the distribution of lubricant around the Slide Valve Seat (18). An uneven distribution of lubricant may allow leakage to occur between the Slide Valve Seat (18) and the Slide Valve Strip (3) during a plate change operation. Refer to [Lubricant information](#) to help you to select a lubricant for your application.

Orifice plate seal material is another factor to consider when selecting components for low temperature services. Refer to [Conditions and specifications "Orifice plate seal material temperature limitations"](#) to help you to select an orifice plate seal for your application.

For Seniors located in low temperature environments (atmospheric temperature ranges of +32° F [0° C] to -20° F [-29° C]), Emerson recommends replacing the standard carbon steel Equalizer Valve (Complete) (1), Bleeder Valve (Complete) (10B), Grease Gun (Complete) (23) and Drain Valve Plug (30) with the low temperature versions listed in the "Low Temp Service" column (refer to [Low temperature service](#)).

Table 2-1: Alternate components

Part number	Description	Plug size	Standard service	Stainless steel corrosive service	Low temperature service
1	Equalizer Valve	complete	1-504-01-011	1-504-01-004	1-504-01-016
10B	Bleeder Valve	2"/14" (complete)	1-504-01-026	1-504-01-040	1-504-01-040
10F	Bleeder Valve	16" only (complete)	1-504-01-028	1-504-01-041	1-504-01-041
23	Grease Gun	Complete	1-504-01-051	1-504-01-050	1-504-01-071
30	Drain Plug	1/2" - 14 NPT	1-507-01-103	1-507-01-143	1-507-01-170
30	Drain Plug	3/4" - 14 NPT	1-507-01-104	1-507-01-144	1-507-01-171
30	Drain Plug	1" - 11.5 NPT	1-507-01-105	1-507-01-145	1-507-01-172

2.1.7 Design considerations

Owners and operators select and place Daniel fittings in a variety of flow measurement services around the world with successful results. Emerson personnel understand that each flow measurement service has its own set of unique process and environmental

conditions. Although Emerson designs, builds and offers a product line that may be applicable to most flow measurement services, it is the end user's responsibility to match the fitting to the service to achieve successful results.

Important

Product owners and operating personnel must evaluate both process fluid and environmental conditions of an intended service and select the appropriate fitting to match those service requirements. Once selected, the product owners and operating personnel must place the Daniel fitting in a well-designed piping system.

Below is a list of some, but not all, pipe design conditions to consider:

- Service operating pressure
- Service testing pressures
- Service process temperature and ambient site temperatures
- Mass of fluid in process and test conditions
- Chemical composition and toxicity of fluid in operating conditions
- Traffic, wind and earthquake at loading site
- Reaction forces and moments (meter position, supports, attachments, piping, etc.)
- Corrosion, erosion, fatigue, etc.
- Decomposition of unstable fluids in operating and test conditions
- Possible damage from external fire

2.1.8 Installation configurations

Up to 12" nominal size (all ANSI Classes)

Product owners and operating personnel may install any Daniel Senior fitting, up to 12-inch line size, in one of two configurations. One configuration is to install the fitting in piping system with product flowing in a horizontal direction (Figure 2-3). The other is to install the fitting in piping system with product flowing in a vertical direction (Figure 2-4).

Figure 2-3: Horizontal Flow

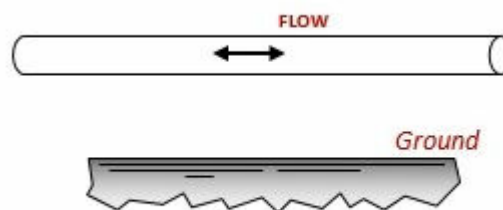

Installing the fitting in a vertical flow direction (see Figure 2-4) gives a product owner and operating personnel the option to fix the fitting in any position parallel to the ground. Although the insertion of the fitting in the vertical flow direction can be vertical UP or

vertical DOWN, it is recommended the fitting be in the vertical down flow direction to reduce the potential of debris collecting on the orifice plate.

Figure 2-4: Vertical flow

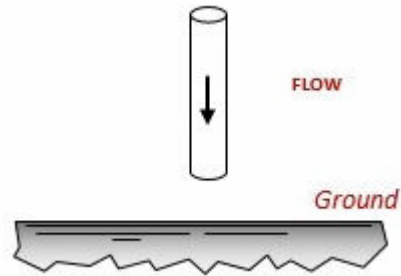

Installing the fitting in a horizontal flow direction gives a product owner and operating personnel the option to fix the final position of the fitting parallel (Figure 2-5 or Figure 2-7), or perpendicular (Figure 2-6) to the ground as shown.

Figure 2-5: Parallel to the ground "Right side" position

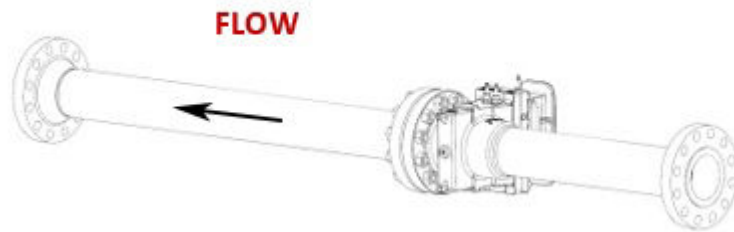

Figure 2-6: Perpendicular to the ground "Normal" position

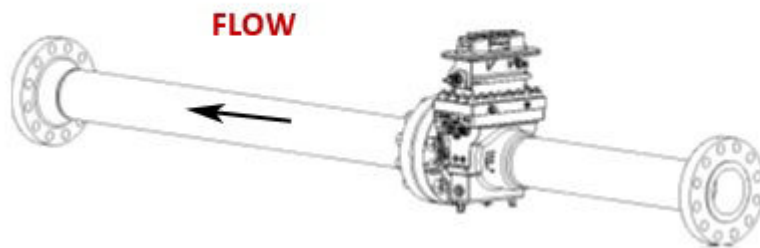
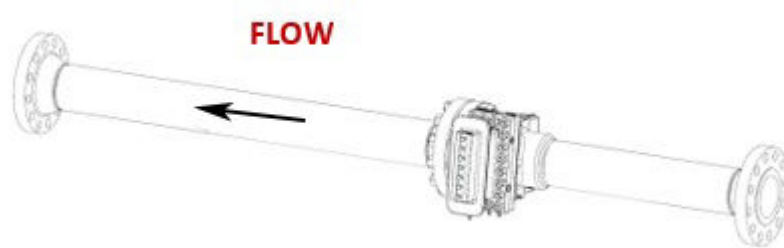

Figure 2-7: Parallel to the ground "Left side" position



14" and larger nominal size (all ANSI Classes)

14" and larger Senior fittings are recommended to be installed only in Horizontal Flow - "Normal Position" direction per [Figure 2-6](#).

Part III

Operate

3 Commissioning

3.1 Commission the Daniel Senior Orifice Fitting



DANGER

FLUID EXPLOSION HAZARD

The Senior is a device that contains fluid at elevated pressure.

Failure to follow the instructions in this manual will result in death or serious injury.

Commissioning is the process of verifying that a system performs in accordance with the user's intended operational, maintenance, and measurement requirements. Emerson provides the following procedures to guide personnel in verifying that the Senior performs in accordance with the user's intended requirements.

Pre-Commissioning

Ensure that the following checklist is met prior to commissioning the Senior:

- The internal pressure throughout the Senior is equal to atmospheric pressure (0 psig / 0 barg).
- Confirm that the flow directional indicator (arrow or "INLET"/"OUTLET" tags) positioned on the Senior Body (4) corresponds with the intended fluid flow direction of the measurement system.
- Check shipment to verify that the shipping kit contains an Operating Wrench (2), Grease Gun (23), Indicator Plate (5A-LH marked "LH" for left-hand side operation and 5A-RH marked "RH" for right-hand side operation) and (2 EA) Indicator Pointer (5B).
- Confirm the proper operating clearance around the Senior per information contained in the Daniel technical guide "DAN-DIF-TG-11-1003".
- Check accessibility and Operating Wrench (2) clearance at the following Senior locations:
 1. Lower Plate Carrier Shaft (6)
 2. Upper Plate Carrier Shaft (7)
 3. Bleeder Valve ()
 4. Equalizer Valve (1)
 5. Slide Valve Shaft (5)
- Confirm the Operating Wrench (2) operational clearances for the Plate Carrier (8DM or 8DMC) extraction, and meter tap equipment draw clearance.
- Install the Grease Gun(s) (23) into holes in the base of the Top (14) as stated below:
 - Remove the plastic shipping plugs
 - Put thread sealer on the end threads of the Grease Gun Body (23) and tighten securely. Check the accessibility to the Grease Gun(s) (23) after installation.
 - Adjust the Senior's position if required.

- Install the Indicator Pointer (5B) on to the Body (4) by tapping the two drive screws into the holes located above the Slide Valve Shaft (5).
- Install the Indicator Plates (5A-LH and 5A-RH) on the Slide Valve Shaft (5), directly below the Indicator Pointer (5B).
- Orient the Indicator Plate (5A-LH and 5A-RH), as stated below, depending on the shaft's left or right side location (The right hand and left hand Indicator Plates (5A-LH and 5A-RH) are different and not interchangeable):
 - Shaft on the left hand side facing with the flow (standard LH position): when the shaft is rotated clockwise until it stops, the Indicator Plate (5A-LH) word OPEN should appear below the Indicator Pointer (5B). Install the Indicator Plate (5A-LH) on the shaft in this position and tighten the Set Screw (10G) securely.
 - Shaft on the right hand side facing with the flow (standard RH position): When the shaft is rotated counterclockwise until it stops, the Indicator Plate (5A-RH) word OPEN should appear below the Indicator Pointer (5B). Install the Indicator Plate (5A-RH) on the shaft in this position and tighten the Set Screw (10G) securely.
 - After installation, rotate the Slide Valve Shaft (5) until it stops. The word CLOSED on both Indicator Plates (5A-LH and 5A-RH) should appear below the Indicator Pointer (5B).
- Plate Carrier shipment verification
The Seniors leave the factory with the Plate Carriers (8DM or 8DMC) in the Body (4) to prevent the damage of the Plate Carrier (8DM or 8DMC) or the slide valve assembly during transit. Whether or not the Senior arrives directly from the factory, installation personnel must remove the Clamping bar and open the Top (14) and the Slide Valve Shaft (5) to ensure that the Plate Carrier (8DM or 8DMC) is inside. The Plate Carrier (8DM or 8DMC) should be removed before performing any tests.
- Orifice plates and Seal Rings verification
The factory packages the Orifice Plates (13) and Seal Rings units (8E-DSC or 8E-DS; 8TSC or 8TS; 8MSC or 8MS; 8SNC or 8SN) separate from the fitting.
- With the slide valve in the fully opened position, follow these instructions:
 - Rotate the Lower Plate Carrier Shaft (6) first.
 - Rotate the Upper Plate Carrier Shaft (7) to remove the Plate Carrier (8DM or 8DMC).
 - Put the Plate Carrier (8DM or 8DMC) in a safe, protected area for use later in the installation process.
 - Replace the Sealing Bar (9 or 9HP), the Sealing Bar Gasket (9A, 9AHP or 9CF) and the Clamping Bar (12 or 12HP)
 - Tighten and secure all Clamping Bar Screws (11) per the information and procedures contained in [Torque information](#)



CAUTION

LOOSE CLAMPING BAR SCREW HAZARD

The factory assembled and shipped this product with loose clamping bar screws. Tighten all Clamping Bar Screws(11) per the information and procedures contained in [Torque information](#) before applying pressure to this product.

Failure to comply may result in death, serious injury or equipment damage.

3.2 Commission the line pressure test

After installing the Daniel Senior Orifice Fitting, personnel must perform a pressure test for the service line that includes, but is not limited to, the meter tube and Senior.

Commissioning line pressure test start checklist:

- The internal pressure throughout the Senior is equivalent to atmospheric pressure (0 psig / 0 barg).
- The Slide Valve Shaft (5) must be in the "OPEN" position.
- The Equalizer Valve (1) must be in the "OPEN" position.
- The Bleeder Valve (10B10F) must be in the "CLOSED" position.
- Orifice Plate Carrier (8DM) is installed in the Senior Body (4).
- The Orifice Plate (13) and Orifice Plate Sealing Unit (8E-DS or 8TS or 8MS or 8SN) is not installed on the Orifice Plate Carrier (8DM).
- The Sealing Bar Gasket (9A) and Sealing Bar (9) are installed.
- The Clamping Bar (12) is installed.
- All Clamping Bar Screws (11) are tightened and secured per the information and procedures contained in [Torque information](#)



WARNING

FLUID EXPLOSION HAZARD

Never pressurize a unit above the limits recommended in this manual. Before pressurizing the Daniel Senior Fitting, confirm the maximum allowable operating pressure (MAOP) of each item in the system.

Over-pressurizing the Daniel Senior fitting could lead to an explosive release of fluid resulting in death, serious injury or damage to the Senior.

Procedure

1. Install a pressure gauge in a location on the Senior or the piping system that will indicate the pressure contained in the Fitting. The gauge should have a maximum pressure rating slightly above the maximum pressure to be applied during the test.

Important

Emerson hydrostatically tests every Senior unit for fluid retention, under factory controlled conditions, to a minimum pressure of 1.5 times its rated maximum allowable operating pressure. If purchased alone, without a meter tube, any hydrostatic testing of the meter tube assembly is the responsibility of the product owners or product operating personnel.

2. Slowly pressurize the system containing the Senior at a rate of 1 psig per second (0.07 bars per second) until the pressure inside the Senior reaches 20 psig (1.4 barg) then stop and hold pressure for five minutes.

Important

During the five-minute hold period, apply a leak detection solution to all joint and connector areas of the Senior and line connections. No leakage should be visibly detectable or audibly detectable during the hold period.

3. If a leak is detected, mark the leak area with a marker and reduce the pressure inside the Senior to 0 psig (0 barg). Tighten any fastener or connector adjacent to the leak area and repeat the leak test again.
4. If after several attempts to contain the leakage, the leakage persists, call Flow Lifecycle Services for Daniel products for assistance. Contact information is found in the back of this manual.
5. Once the 20 psig (1.4 barg) leak test is complete, and no leaks are detected, slowly raise the pressure inside the Senior at a rate of 10 psig per second (0.7 barg per second) to the maximum operating pressure of the lowest rated item in the system. However, it should not to exceed 1.5 times the noted rated working pressure of the Senior. Hold the maximum operating pressure on the system for a period of ten minutes.

Important

During the ten-minute hold period, apply a leak detection solution to all joint and connector areas of the Senior and line connections. No leakage should be visibly detectable or audibly detectable during the hold period.

6. If a leak is detected, mark the leak area with a marker and reduce the pressure inside the Senior to 0 psig (0 barg). Tighten any fastener or connector adjacent to the leak area and repeat the leak test again.
7. If after several attempts to contain the leakage, the leakage persists, call Flow Lifecycle Services for Daniel products for assistance.



WARNING

PRESSURIZED FLUID HAZARD

When opening the bleeder valve (10B) or venting the Top (14) through the bleeder valve (10B), direct the released pressurized fluid away from any individual in accordance with local environment regulations to a safe area.

The bleeder valve (10B) releases pressurized fluid that may cause contamination and/or accumulation of volatile gas mixtures. Failure to comply may cause death or serious injury.

8. Slowly release the pressure from the Senior until the pressure gauge reads zero (0) psig by venting the Top (14) through the bleeder valve (10B).
9. Close the slide valve by rotating the Slide Valve Shaft (5). Close the Equalizer Valve (1). Open the Bleeder Valve (10B).
Steps 10 and 11 are for the Seniors equipped with lubricated slide valves only. For Soft Seat equipped Seniors, skip these steps.
10. Once the valves are in position as described in [Step 9](#), remove the stem from the Grease Gun (23) and insert a lubricant stick into the Grease Gun (23).

 **WARNING**

PRESSURIZED FLUID HAZARD

Using the Grease Gun (23), inject grease into the slide valve seat channels at a rate of 4 to 6 turns per minute and only under the following conditions:

- Bleeder Valve is open.
- Sealing bar/Clamping bar is in place and tight.

Injection of the grease at a faster rate will lead to the separation of the valve strip from the valve seat, resulting in release of pressurized fluid which may cause death or serious injury.

11. Return the stem to the Grease Gun (23) and begin turning the stem by hand into the Grease Gun (23) until resistance is felt.

3.3 Orifice Plate Installation

After completion of the commissioning line pressure test in [Commission the line pressure test](#), install and lower the Plate Carrier (8DM or 8DMC) and Orifice Plate Assembly (13) into the Body (4) to begin measurement operations.

 **WARNING**

EXPLOSION HAZARD

Ensure that the Daniel Senior Orifice Fitting is at atmospheric pressure.

Performing the Orifice Plate (13) installation with the Senior above atmospheric pressure may lead to an explosive release resulting in death or serious injury.

Orifice Plate (13) installation start checklist:

- Senior is at atmospheric pressure .
- The Slide Valve Shaft (5) must be in the "OPEN" position
- The Equalizer Valve (1) must be in the "OPEN" position
- The Bleeder Valve (10B) must be in the "OPEN" position

Procedure

1. Remove the Clamping Bar (12 or 12HP) by loosening all the Clamping Bar Screws (11), two turns maximum, and by sliding the bar from the slot.
2. Remove the Sealing Bar (9 or 9HP) and the Sealing Bar Gasket (9A, 9A-HP or 9CF).
3. The three basic components of all Daniel Plate Carrier (8DM or 8DMC) assemblies are:
 - Plate Carrier (8DM or 8DMC)
 - Orifice Plate Seal Ring (8E-DS/8E-DSC, 8TS/8TSC, 8E-DVS, 8SN/8SNC, or 8MS/8MSC)
 - Orifice Plate (13)
 - a) Assemble the Orifice Plate (13), with the appropriate seal ring, into the Plate Carrier (8DM or 8DMC). If a DSC or DSDVS seal is used, lubricate both seal

faces with a safe-for-service light oil or grease. Refer to "Senior Orifice Fitting Technical Guide: DAN-DIF-TG-11-1003".

All 2"-8" Daniel Senior Orifice Fitting Plate Carriers (8DMC) designed for API-14.3 have two important features that will help field technicians properly align it prior to installation. The first feature is a NOTCH, and the second feature is a BOSS or SPRING PLUNGER. (Refer to [Orifice Plate Installation](#)).

- a) In order to ensure correct measurement and to optimize metering performance, field service technicians must properly install the 2"-8" Plate Carrier (8DMC) assembly into the Senior.
4. Orient the 2"-8" Plate Carrier (8DMC) assembly with the notch down. The notch end of the 2"-8" Plate Carrier (8DMC) assembly must enter the Senior first.

Important

Install the Plate Carrier (8DM) assembly into the Senior with the gear rack facing downstream (refer to [\(#unique_43/unique_43_Connect_42_fig_vsz_dzp_jdb\)](#) and [\(Figure 3-2\)](#)).

Failure to align and install Plate Carrier (8DM) assembly as instructed will cause erroneous measurement results.

5. Align the plate carrier gear rack teeth to the Plate Carrier (8DM or 8DMC) shaft pinion on the Senior when installing the Plate Carrier (8DM or 8DMC) assembly.

Figure 3-1: Plate carrier (8DM or 8DMC) plunger and notch location

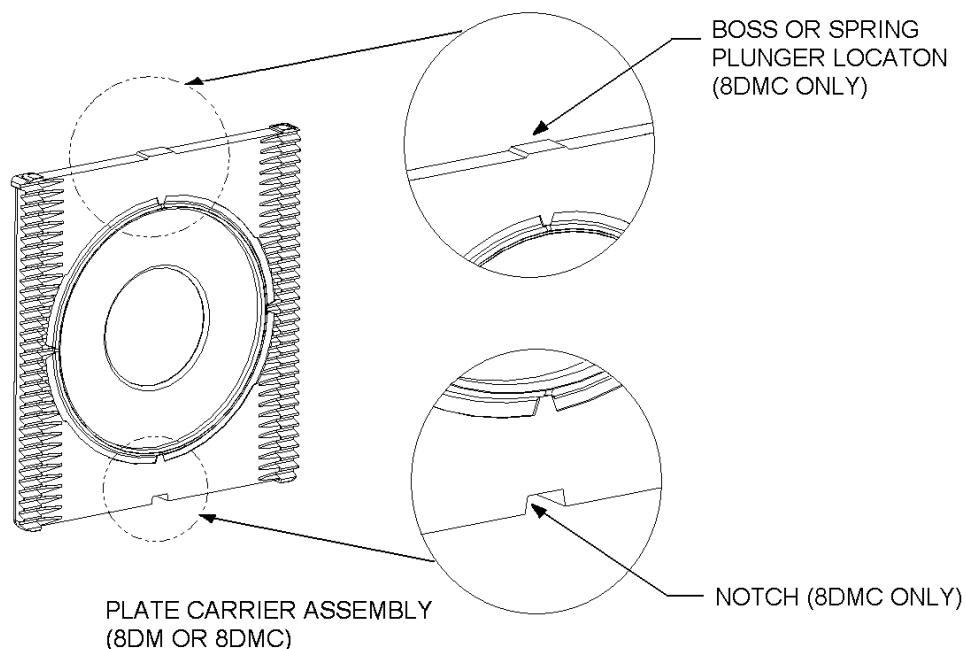

The diagram below depicts the proper orientation of the Plate Carrier (8DM or 8DMC) assembly prior to lowering it into the measurement position in the Senior.

Figure 3-2: Orientation of plate carrier (8DM or 8DMC) prior to installation

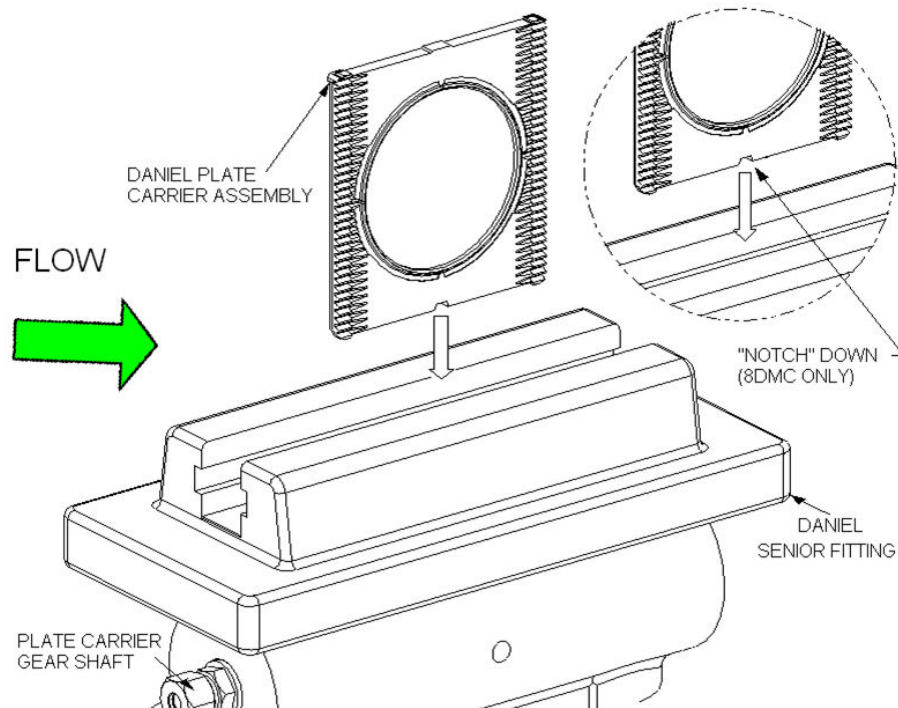

NOTES:

- The gear rack side of the Plate Carrier (8DM or 8DMC) assembly must face the downstream direction of flow.
- If the Orifice Plate (13) bore has a bevel, the bevel shall face the downstream direction of flow.

6. Rotate the Upper Plate Carrier Shaft (7) a minimum of 1/4 turns OPPOSITE of the direction used to lower the Plate Carrier (8DM or 8DMC) assembly. This will allow it to "align" itself with the Top (14) shaft gear teeth.
7. Once the Plate Carrier (8DM or 8DMC) assembly is aligned, rotate the Upper Plate Carrier Shaft (7) in the direction to lower it from the Top (14) to the Body (4).
8. Once the Plate Carrier (8DM or 8DMC) assembly is clear of the Upper Plate Carrier Shaft (7), rotate the Lower Plate Carrier Shaft (6) until the Plate Carrier (8DM or 8DMC) assembly is completely inserted into the Body (4).
9. Install the Sealing Bar (9 or 9HP), the Sealing Bar Gasket (9A, 9A-HP or 9CF), and the Clamping Bar (12 or 12HP) in position on the Top (14) and tighten the Clamping Bar Screws (11). Refer to [Torque information](#) for torque values.

 **CAUTION**

LOOSE CLAMPING BAR SCREW HAZARD

The factory assembled and shipped this product with loose clamping bar screws. Tighten all Clamping Bar Screws(11) per the information and procedures contained in [Torque information](#) before applying pressure to this product.

Failure to comply may result in death, serious injury or equipment damage.

10. Rotate the Slide Valve Shaft (5) to the CLOSED position. This closes the slide valve, separating the Body (4) from the Top (14).
Steps 11 and 12 are for Seniors equipped with lubricated slide valves only. For Soft Seat equipped Seniors, skip to step 13.
11. Once the Slide Valve Shaft (5) is in the CLOSED position, remove the stem from the Grease Gun (23) and insert a lubricant stick (Refer to [Lubricant information](#)) into the Grease Gun (23).

 **WARNING**

PRESSURIZED FLUID HAZARD

Using the Grease Gun (23), inject grease into the slide valve seat channels at a rate of 4 to 6 turns per minute and only under the following conditions:

- Bleeder Valve is open.
- Sealing bar/Clamping bar is in place and tight.

Injection of the grease at a faster rate will lead to the separation of the valve strip from the valve seat, resulting in release of pressurized fluid which may cause death or serious injury.

12. Return the stem to the Grease Gun (23) and begin turning the stem by hand into the Grease Gun (23) until resistance is felt. Once resistance is felt, use the supplied Daniel Operating Wrench (2) to continue to turn the stem at a rate of 4 to 6 turns per minute.
13. Close both the Equalizer (1) and the Bleeder Valves (10B).
14. Remove any commissioning equipment (flanges, tubing, etc.) from the system.
The Senior is now ready for final pressurization and operation.

Part IV

Maintain

4 Normal operation conditions

4.1 Maintenance

4.1.1 Recommendations for lubrication

Under normal measurement conditions, Emerson recommends lubricating the slide valve and exercising several key components of the Daniel Senior Orifice Fitting every thirty days (Refer to [Component exercise](#)). If the plate changing operations are performed within this period, omit this operation.

4.1.2 Lubrication

Important

The information in this section, [Lubrication](#), DOES NOT apply to Seniors equipped with Soft Seat slide valves.

In order to perform the maintenance operation described in this section, the following maintenance check list must be met first:

- The slide valve must be in the "CLOSED" position.

**WARNING****PRESSURIZED FLUID HAZARD**

When opening the bleeder valve (10B) or venting the Top (14) through the bleeder valve (10B), direct the released pressurized fluid away from any individual in accordance with local environment regulations to a safe area.

The bleeder valve (10B) releases pressurized fluid that may cause contamination and/or accumulation of volatile gas mixtures. Failure to comply may cause death or serious injury.

- The Bleeder Valve (10B) must be in the "OPEN" position.
- The Equalizer Valve (1) must be in the "CLOSED" position.
- The Senior must contain 100 psig minimum line pressure.

Procedure

1. Remove the stem from the Grease Gun (23) and insert a lubricant stick into the Grease Gun (23).

Figure 4-1: Step 1

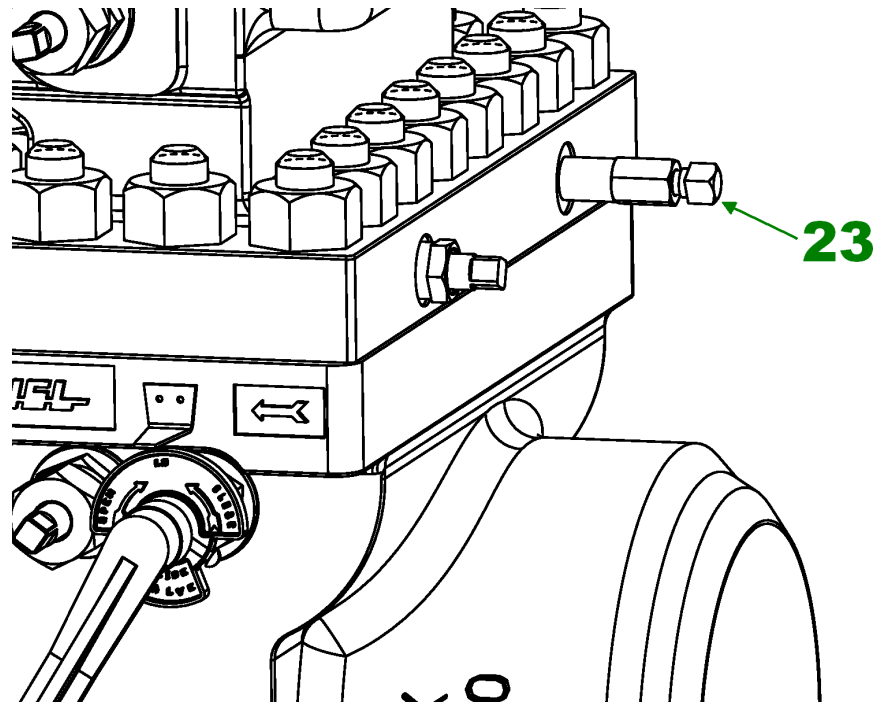
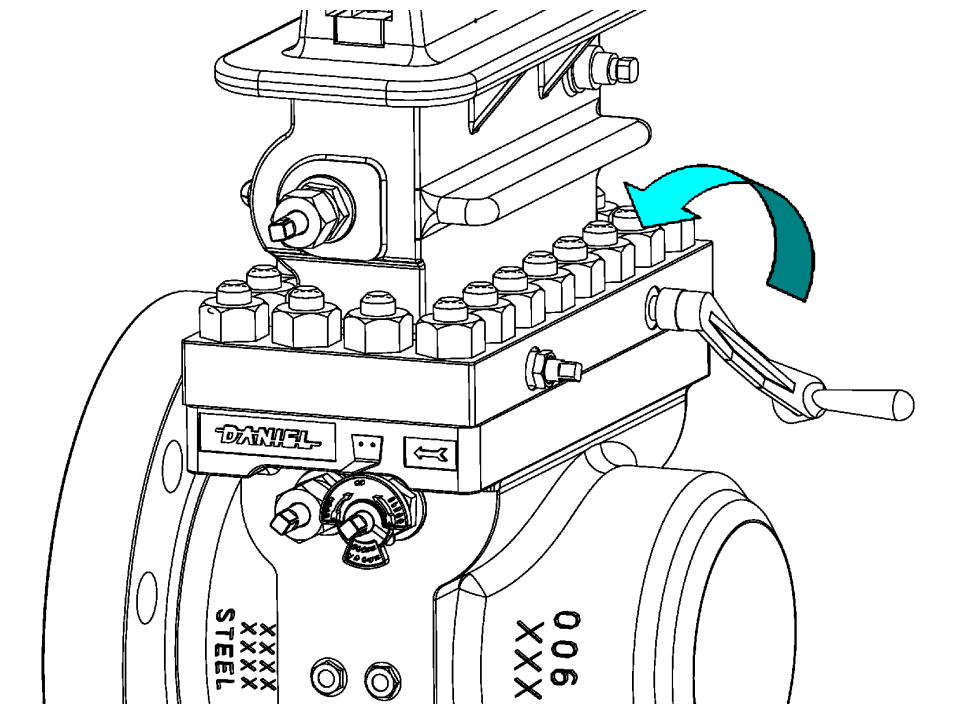

Figure 4-2: Step 1A



! WARNING

PRESSURIZED FLUID HAZARD

Using the Grease Gun (23), inject grease into the slide valve seat channels at a rate of 4 to 6 turns per minute and only under the following conditions:

- Bleeder Valve is open.
- Sealing bar/Clamping bar is in place and tight.

Injection of the grease at a faster rate will lead to the separation of the valve strip from the valve seat, resulting in release of pressurized fluid which may cause death or serious injury.

2. Return the stem to the Grease Gun (23) and begin turning it clockwise by hand into the Grease Gun (23) until resistance is felt. Once this is done, use the supplied Operating Wrench (2) to continue to turn the stem at a rate of 4 to 6 turns per minute.

Figure 4-3: Step 2

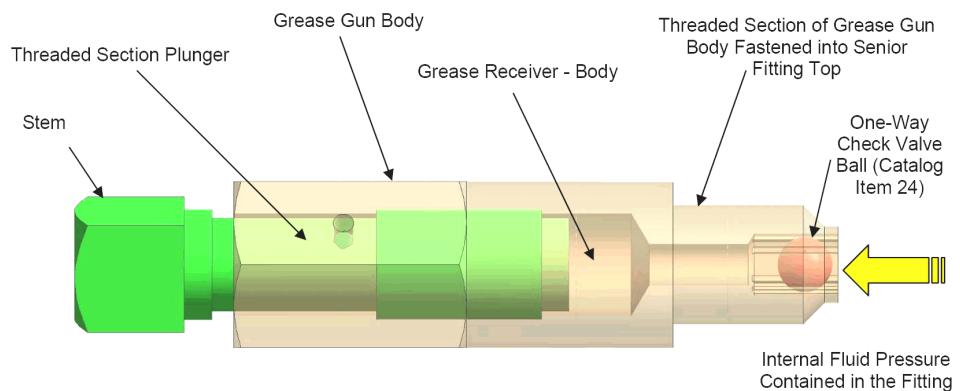

Grease Gun (23)

Important

By turning the stem of the Grease Gun (23) at a rate of 4 to 6 turns per minute, the lubricant is forced through the Slide Valve Seat (18) channels at a rate that allows the lubricant to travel freely, yet not separate the valve strip from the valve seat. This method will keep fresh grease in the lubrication passages.

3. Close Bleeder Valve (10B).

4.1.3 Component exercise

Prerequisites

In order to perform the maintenance operation described in this section, the following component exercise start check list must be met:

- The slide valve must be in the "CLOSED" position,
- The Bleeder Valve (10B) must be in the "CLOSED" position.
- The Equalizer Valve (1) must be in the "OPEN" position.

At this point the fluid pressure in the Top (14) will equal the fluid pressure in the Body (4).

Procedure

1. If the differential pressure is greater than 200 inches of H₂O, reduce the differential pressure across the meter to a maximum of (200 inches of H₂O) 7.2 psig.
2. Rotate the Upper Plate Carrier Shaft (7) located in the Top (14) several times in both directions. The Shaft (7) should turn freely.
3. Rotate the Slide Valve Shaft (5) in one direction until it stops. Then rotate the Slide Valve Shaft (5) in the opposite direction until it stops. Repeat this sequence several times. The slide valve should travel freely in both directions with light resistance. Leave the slide valve in the OPEN position.

Important

The following operation will affect the flowing differential and will be shown on any chart or instrument, keep records of differential, unless these instruments are isolated.

4. Rotate the Lower Plate Carrier Shaft (6), located in the Body (4), one turn to raise the Plate Carrier (8DM or 8DMC).
5. Rotate the Lower Plate Carrier Shaft (6) one turn in the opposite direction to lower the Plate Carrier (8DM or 8DMC).
This operation raises and lowers the Plate Carrier (8DM or 8DMC) in and out of the flow stream. An initially high resistance to turning will be encountered when the Orifice plate (13) seal (see "Senior Orifice Fitting Technical Guide: DAN-DIF-TG-11-1003") is loosened from the Senior seal surface. Resistance to turning will also be present when the Plate Carrier (8DM or 8DMC) is lowered into its measurement position again.
6. Return the Plate Carrier (8DM or 8DMC) to the fully seated position in the Body (4).
7. Close the slide valve and close the Equalizer Valve (1).

 **WARNING**

PRESSURIZED FLUID HAZARD

When opening the bleeder valve (10B) or venting the Top (14) through the bleeder valve (10B), direct the released pressurized fluid away from any individual in accordance with local environment regulations to a safe area.

The bleeder valve (10B) releases pressurized fluid that may cause contamination and/or accumulation of volatile gas mixtures. Failure to comply may cause death or serious injury.

8. Open the Bleeder Valve (10B) to vent the Top (14).
Steps 9 and 10 are ONLY required for the Seniors equipped with grease assisted, metal-to-metal slide valves. Personnel operating the Seniors equipped with O-ring seal "soft seat" design slide valves, skip to step 11.
9. Remove the stem from the Grease Gun (23) with the Operating Wrench (2) and insert a lubricant stick into the Grease Gun (23).

 **WARNING**

PRESSURIZED FLUID HAZARD

Using the Grease Gun (23), inject grease into the slide valve seat channels at a rate of 4 to 6 turns per minute and only under the following conditions:

- Bleeder Valve is open.
- Sealing bar/Clamping bar is in place and tight.

Injection of the grease at a faster rate will lead to the separation of the valve strip from the valve seat, resulting in release of pressurized fluid which may cause death or serious injury.

10. Return the stem to the Grease Gun (23) and begin turning the stem by hand into the Grease Gun (23) until resistance is felt. When resistance is felt, apply the Operating Wrench (2) to the Grease Gun (23) and continue to turn the stem into the Grease Gun (23) at a rate of 4 to 6 turns per minute until a seal is achieved.

Important

By turning the stem of the Grease Gun (23) at a rate of 4 to 6 turns per minute, the lubricant is forced through the Slide Valve Seat (18) channels at a rate that allows the lubricant to travel freely, yet not separate the valve strip from the valve seat. This method will keep fresh grease in the lubrication passages.

If the addition of grease does not reduce the flow from the open Bleeder Valve (10B) to zero, follow these steps:

- Close the Bleeder Valve (10B),
- Open the Equalizer Valve (1), and move the Slide Valve Shaft (5) from the CLOSED to the OPEN position, and back to the CLOSED position, repeating this action several times.
- Return the Slide Valve Shaft (5) back to the CLOSED position.
- Close the Equalizer Valve (1) and repeat the lubrication process.
- Open the Bleeder Valve (10B).

If leakage is still present, close the Bleeder Valve (10B) and leave the Slide Valve Shaft (5) in the CLOSED position and schedule maintenance on the Senior.

11. Close the Bleeder Valve (10B).

If at any point during the exercise of the components, the resistance encountered when turning a shaft is greater than the torque applied by hand using the Wrench (2), further inspection of the Senior is required.

4.2 Orifice plate installation and removal instructions

4.2.1 Plate change procedure overview

Follow these instructions during every plate change.



DANGER

FLUID EXPLOSION HAZARD

Follow the instructions below to avoid inadvertent or accidental opening of the slide valve and the propulsion of fluid or internal components from the Top (14).

Failure to comply will result in death or serious injury.

Never place any part of your body over the plate carrier slot opening (refer to [Figure 4-4](#)) of the Top (14) when the Sealing Bar Gasket (9A, 9A-HP or 9CF), the Sealing Bar (9 or 9HP) and the Clamping Bar (12 or 12HP) are removed from the Daniel Senior Orifice Fitting and the line is under pressure.

Never place the Operating Wrench (2) on the Slide Valve Shaft (5) (refer to [Figure 4-5](#)) when the Sealing Bar Gasket (9A, 9A-HP or 9CF), the Sealing Bar (9 or 9HP) and the Clamping Bar (12 or 12HP) are removed from the Senior and the line is under pressure.

Figure 4-4: Top (14) KEEP OUT ZONE ⁽⁷⁾

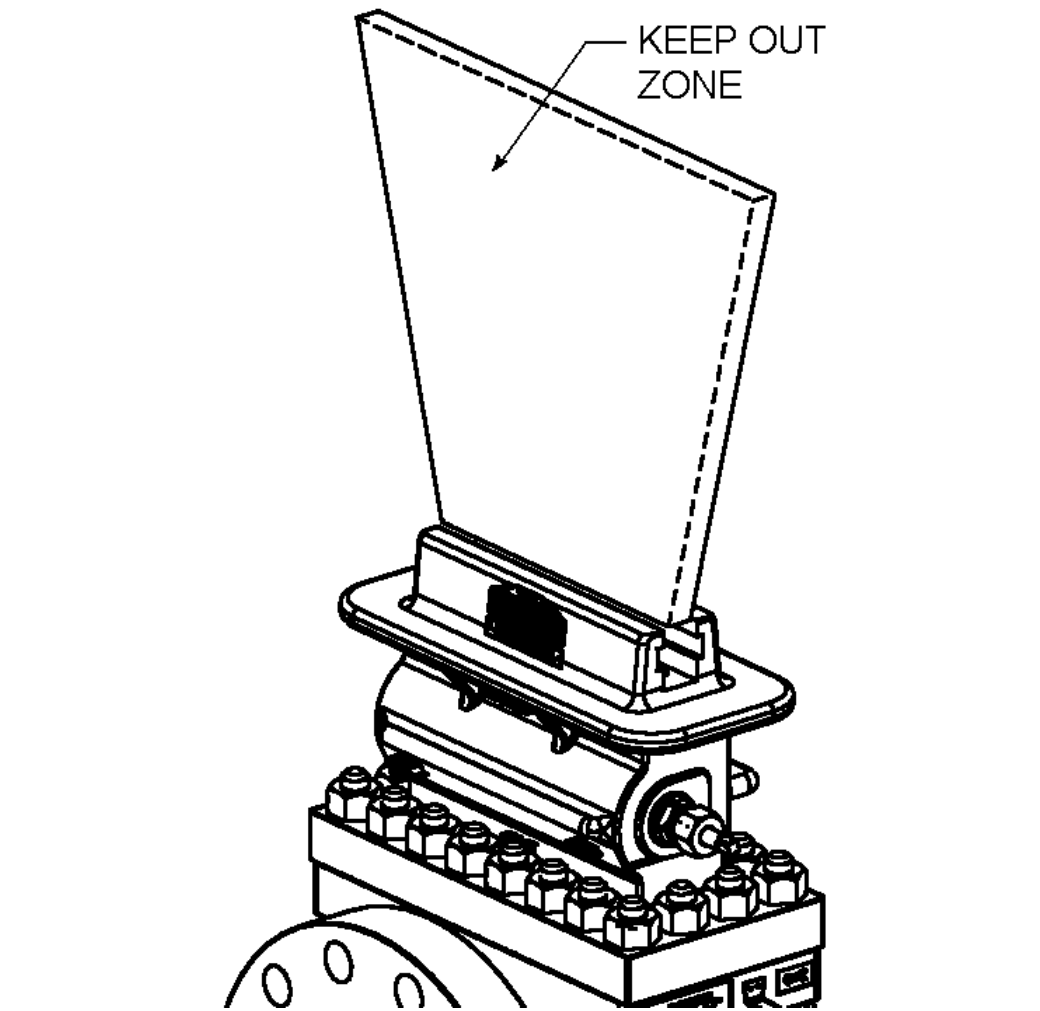

(7) Daniel Senior Orifice Fitting shown in vertical position. The KEEP OUT ZONE includes the plate carrier slot opening of the Top (14) even when the Senior is positioned horizontally (laying on its side).

Figure 4-5: Improper Location of Operating Wrench (2) During an Orifice Plate Change Operation

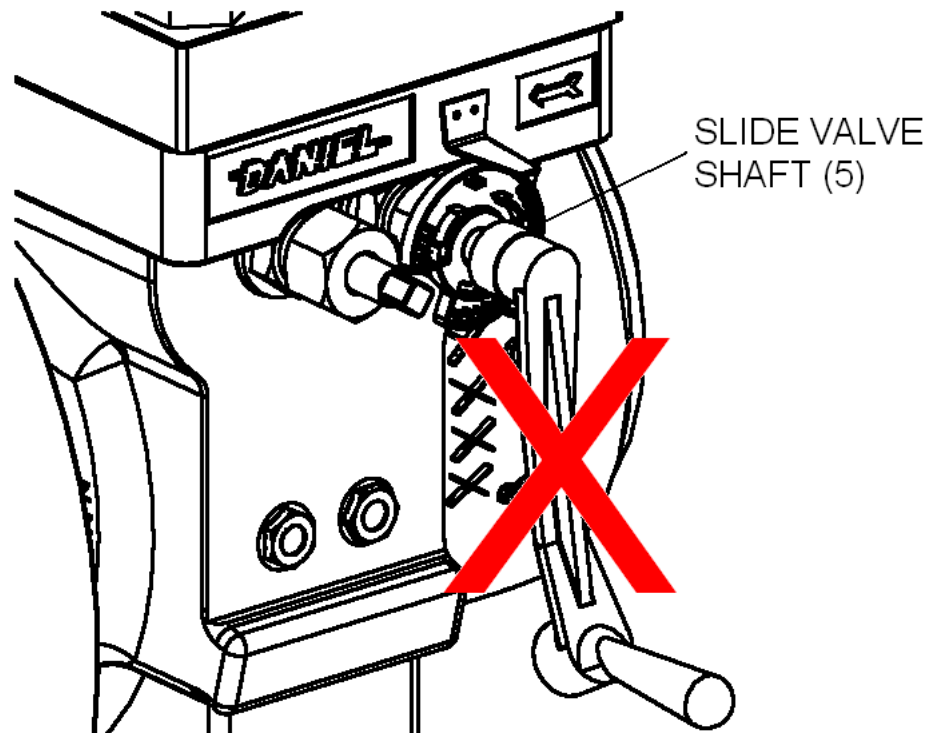

4.2.2

Selecting an appropriate plate change procedure

! **WARNING**

EXPLOSION HAZARD

The Daniel Senior Orifice Fitting contains fluid at elevated pressure. Ensure to follow the instructions below for proper installation and removal of the plate.

Failure to comply can cause an explosive release and may result in death or serious injury.

Important

In order to perform a safe and efficient plate change operation with a Senior, the on-site personnel must evaluate both the service and environmental conditions prior to beginning this operation. These conditions may have a dramatic effect on the time required for an operator's ability to return the Senior to its measurement condition.

As stated in the product description section of this manual, the Seniors utilize a "dual chamber" design. A slide valve contains the line pressure in the Body (4) during the plate extraction from the Senior and plate installation into the Senior. Emerson offers both an O-Ring seal "softseat" slide valve design, and a grease assisted, metal-to-metal slide valve design. Both designs ensure the optimum seal performance during this stage in the Orifice Plate (13) change. Under some service conditions, the grease used in the metal-to-metal slide valve design may migrate into the Top (14). If this was to occur, then the grease assisted metal-to-metal slide valve may not perform optimally and leakage will occur.

There are some services where, based on the characteristics of the fluid within and an intimate knowledge of the system, an operator and owner may allow some leakage past the slide valve during a plate change operation. This decision to allow leakage should be made on a case by case basis and be properly documented, communicated to, and acknowledged by, all personnel involved in the plate change operation. The sole responsibility for a decision to allow leakage lies with both the product owner and product operator. Emerson recommends that owners and operators use either the "Quick Change" or "Extended Time" methods described in this section.

Therefore, when performing an Orifice Plate (13) change on a Senior equipped with a grease assisted, metal-to-metal slide valve, Emerson recommends that at no time shall an operator leave the Sealing Bar (9 or 9HP), the Sealing Bar Gasket (9A, 9A-HP or 9CF), and the Clamping Bar (12 or 12HP) unfastened from the Top (14) except to remove and replace the Orifice Plate Carrier (8DM or 8DMC) from the Senior.

Finally, the operator should never leave any Senior, O-ring seal "soft-seat" slide valve design, or a grease assisted, metal-to-metal slide valve design, unattended while the Sealing Bar (9 or 9HP), the Sealing Bar Gasket (9A, 9A-HP or 9CF), and the Clamping Bar (12 or 12HP) are unfastened and removed from the Top (14).

In order to assist the operator in determining the safest and most efficient means to perform the Orifice Plate (13) change on a Senior equipped with a grease assisted slide valve, Emerson prepared two plate change procedures that an operator may select from.

The operator must select the appropriate procedure based upon their intimate knowledge of both the service and environmental conditions of that particular flow measurement system. The two Orifice Plate (13) change procedures described below are the "Quick Change" process, and the "Extended Time" process. If the Senior is equipped with a "soft-seat" slide valve design, then the operator may use either procedure.

An operator can select the "Quick Change" process, based upon their determination that it will take LESS THAN 15 MINUTES from the time the Top (14) fluid is evacuated to the full replacement of the Clamping Bar (12 or 12HP), the Sealing Bar (9 or 9HP), and the Sealing Bar Gasket (9A, 9A-HP or 9CF) after the plate change.

The "Extended Time" process is a procedure selected when the operator determines that the time beginning with the evacuation of Top (14) fluid to the full replacement of the Clamping Bar (12 or 12HP), the Sealing Bar (9 or 9HP), and the Sealing Bar Gasket (9A, 9A-HP or 9CF) after plate change is GREATER THAN 15 MINUTES.

If the operator does not know the time required to perform the Orifice Plate (13) change operation, then the operator must use the "Extended Time" procedure. The table below describes the conditions along with the suitable procedure.

Table 4-1: Plate change procedure selection for grease assisted slide valves and soft seat slide valves

Operator's evaluation of plate change conditions	Procedure	Type of valve
The estimated time period from the Top (14) fluid evacuation to the full replacement of the Clamping Bar (12 or 12HP), the Sealing Bar (9 or 9HP), and the Sealing Bar Gasket (9A, 9A-HP or 9CF) after plate change is: LESS THAN 15 MINUTES	"Quick Change"	Grease assisted slide valve or Soft seat slide valve
The estimated time period from the Top (14) fluid evacuation to the full replacement of the Clamping Bar (12 or 12HP), the Sealing Bar (9 or 9HP), and the Sealing Bar Gasket (9A, 9A-HP or 9CF) after plate change is: GREATER THAN 15 MINUTES	"Extended Time"	Grease assisted slide valve or Soft seat slide valve
The estimated time period from the Top (14) fluid evacuation to the full replacement of the Clamping Bar (12 or 12HP), the Sealing Bar (9 or 9HP), and the Sealing Bar Gasket (9A, 9A-HP or 9CF) after plate change is: UNKNOWN	"Extended Time"	Grease assisted slide valve or Soft seat slide valve

4.2.3 Orifice plate change operation

Important

In order to perform a safe and efficient plate change operation with a Senior, the on-site personnel must evaluate both the service and environmental conditions prior to beginning this operation. These conditions may have a dramatic effect on the time required for an operator's ability to return the Senior to its measurement condition.

The Daniel Senior Orifice Fitting's Top (14) is designed to temporarily hold the Plate Carrier (8DM) during plate change operations.

An operator controlled, grease assisted, slide valve separates the Top (14) from the line pressure to ensure optimum sealing performance. The slide valve grease used to achieve this performance may migrate into the Top (14) during the plate change operation. If this was to occur, the slide valve may not perform optimally and may leak.

The grease migration process is both time and environmental condition dependent. Therefore, Emerson offers two plate change procedures that an operator may choose from in order to perform this process in the safest and most efficient manner. These procedures are the "Quick Change" process and the "Extended Time" process.

The "Quick Change" process is a procedure based upon the operator's knowledge that the entire Orifice Plate (13) removal and installment, the time spent from the Top (14) fluid evacuation to the full replacement of the Clamping Bar (12 or 12HP), the Sealing Bar (9 or 9HP), and the Sealing Bar Gasket (9A, 9A-HP or 9CF) is under fifteen (15) minutes. The "Extended Time" process is a procedure based upon the operator's knowledge that the entire Orifice Plate (13) removal and installment, the time spent from the Top (14) fluid evacuation to the full replacement of the Clamping Bar (12 or 12HP), the Sealing Bar (9 or 9HP), and the Sealing Bar Gasket (9A, 9A-HP or 9CF) is over fifteen (15) minutes.

The procedural differences between these two processes are that, once the Plate Carrier (8DM) is extracted from the Senior, the "Extended Time" process requires the operator to place a new Sealing Bar Gasket (9A, 9A-HP or 9CF) along with replacing the Sealing Bar (9 or 9HP)/Clamping Bar (12 or 12HP) on the Top (14). Additionally, the operator is required to add grease to the Senior prior to removing the Sealing Bar (9 or 9HP)/Clamping Bar (12 or 12HP) in order to reinsert the Plate Carrier (8DM) assembly.

For "Soft Seat" equipped Seniors the operator may use either the "Quick Change" or the "Extended Time" plate removal procedures based upon the immediate service and environmental conditions encountered.

Emerson recommends either the "Quick Change" or the "Extended Time" plate orientation process for users of Seniors equipped with lubricated slide valves. Both the "Quick Change" and the "Extended Time" plate removal processes are provided for users of the Daniel Senior Orifice Fittings with lubricated slide valves.

Requirements for "Quick change" procedure

Pre-requisites

You may use the Quick change procedure for Daniel Senior Orifice Fittings equipped with an O-ring (10E) soft seated valve and for Seniors equipped with a grease-assisted slide valve.

Important

Do not use this procedure if it cannot be finished in less than 15 minutes.

WARNING

TOXIC EXPLOSION HAZARD

Do not perform any of the following steps if the Indicator Plate, the Indicator Pointer, or both are not assembled on the Senior. Call Flow Lifecycle Services for Daniel products for assistance in obtaining replacement components, and follow the instructions provided in [Commission the Daniel Senior Orifice Fitting](#).

Improper installation, maintenance or removal could result in explosive or toxic conditions resulting in death or serious injury.

Figure 4-6: Indicator Plate (5A) and Pointer (5B)

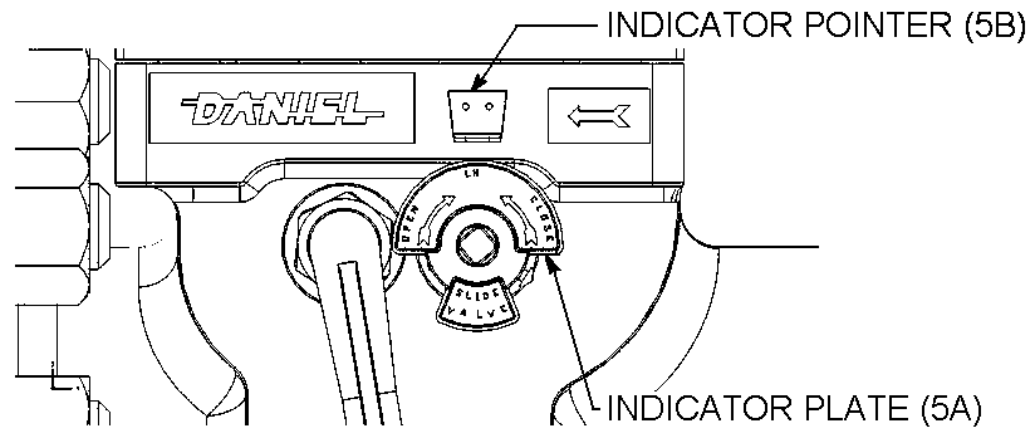

NOTICE

Prior to performing any maintenance or Orifice Plate (13) installation and removal operations on the Senior, personnel must visually confirm the presence of the indicator Plate (5A) on the Slide Valve Shaft (5) and the Indicator Pointer (5B) on the Body (4). Both the indicator plate and the indicator pointer must be installed to operate this equipment safely.

In preparation for the plate removal and installation process, the operator must evaluate the meter system to determine the amount of time between the Top (14) fluid evacuation and the plate change to the full replacement of the Clamping Bar (12 or 12HP), the Sealing Bar (9 or 9HP), and the Sealing Bar Gasket (9A, 9A-HP or 9CF) back on the Top (14).

If the operator determines that the time between the Top (14) fluid evacuation and plate change to the full replacement of the Clamping Bar (12 or 12HP), the Sealing Bar (9 or 9HP), and the Sealing Bar Gasket (9A, 9A-HP or 9CF) back on the Top (14) is less than 15 minutes, then the operator may use the "QUICK CHANGE" procedure.

If the operator determines that the time between the Top (14) fluid evacuation and the plate change to the full replacement of the Clamping Bar (12 or 12HP), the Sealing Bar (9 or 9HP), and the Sealing Bar Gasket (9A, 9A-HP or 9CF) back on the Top (14) is greater than 15 minutes, then the operator must use the "EXTENDED TIME" procedure.

If, for any reason, the operator cannot determine the total time between the Top (14) fluid evacuation and the plate change to the full replacement of the Clamping Bar (12 or 12HP), the Sealing Bar (9 or 9HP), and the Sealing Bar Gasket (9A, 9A-HP or 9CF) back on the Top (14), then the operator must use the "EXTENDED TIME" procedure.

! DANGER

FLUID EXPLOSION HAZARD

Follow the instructions below to avoid inadvertent or accidental opening of the slide valve and the propulsion of fluid or internal components from the Top (14).

Failure to comply will result in death or serious injury.

The following are the conditions required to start the removal procedure of the orifice plate:

- The Senior is operating at line pressure.
- The Plate Carrier (8DM or 8DMC) is located in the measurement position within the Body (4).
- The Indicator Pointer (5B) and the Indicator Plate (5A) are installed on the Senior.
- The Slide Valve Shaft (5) is in the CLOSED position.
- The Equalizer Valve (1) is in the CLOSED position.
- The Bleeder Valve (10B) is in the CLOSED position.
- The Sealing Bar Gasket (9A, 9A-HP or 9CF), the Sealing Bar (9 or 9HP), and the Clamping Bar (12 or 12HP) are fastened to the Top (14).
- Process temperature and ambient temperature values are within range of grease charts.
- Process pressure values are within the range of grease charts.

“Quick change” procedure

To remove the Orifice Plate (13) from the Senior, the operator must first balance the pressure between the Top (14) and the Body (4).

Procedure

1. Open the Equalizer Valve (1) one half to two full turns using the Operating Wrench (2).

Figure 4-7: Step 1

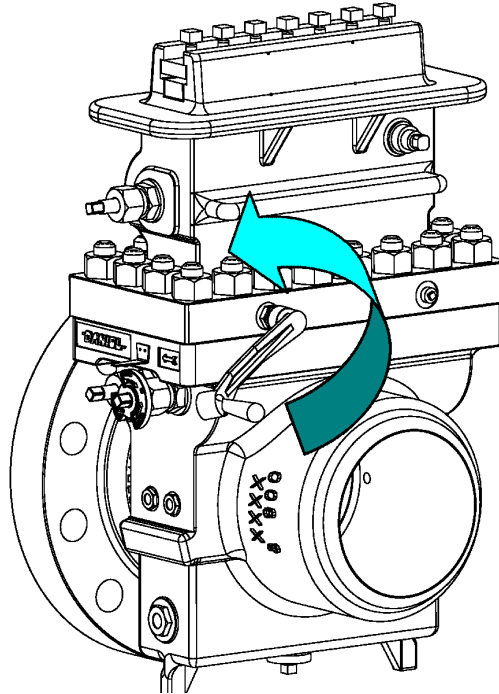

2. Wait several seconds while the pressure in the Top (14) equalizes to that of the Body (4).

Figure 4-8: Step 2

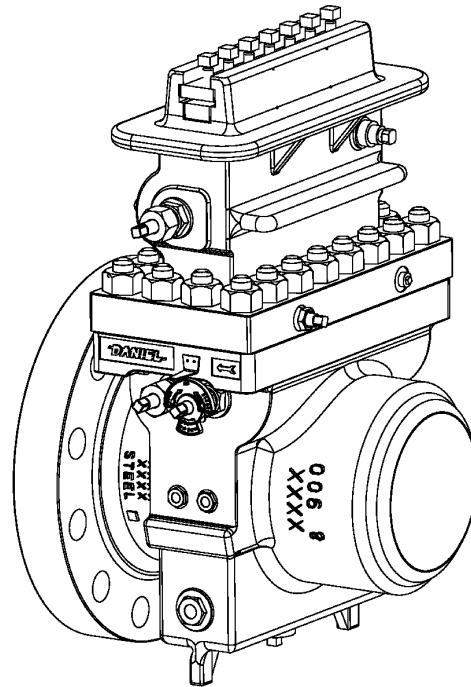

3. Using the Operating Wrench (2) rotate the Slide Valve Shaft (5) until it stops and the OPEN position specified on the Indicator Plate (5A) is in line with the Indicator Pointer (5B).

Figure 4-9: Step 3

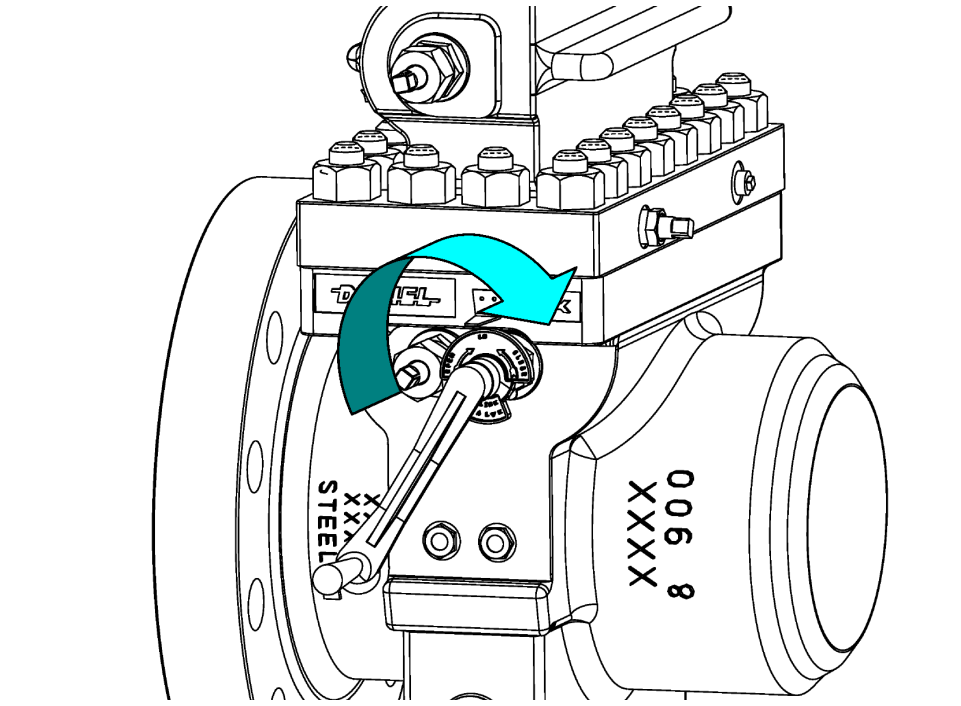

4. Rotate the Lower Plate Carrier Shaft (6), located on the Body (4), using the Operating Wrench (2) in a direction that will move the Plate Carrier (8DM or 8DMC) out of the Body (4) into the Top (14).

Figure 4-10: Step 4

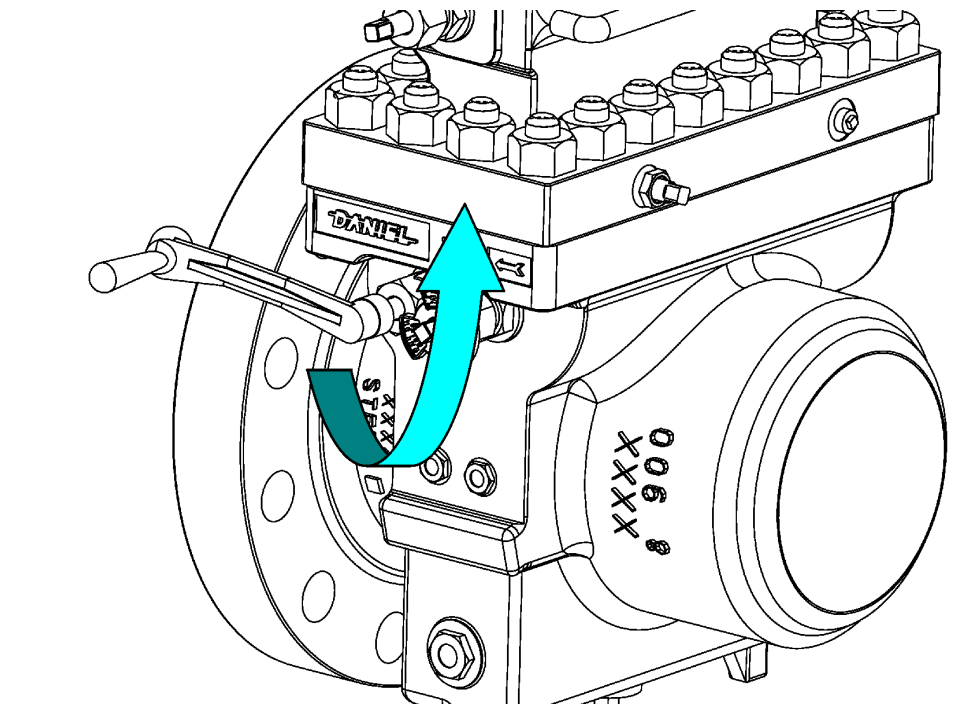

5. Continue to rotate the Lower Plate Carrier Shaft (6) located on the Body (4) until the Upper Plate Carrier Shaft (7) located in the Top (14) begins to rotate

Figure 4-11: Step 5

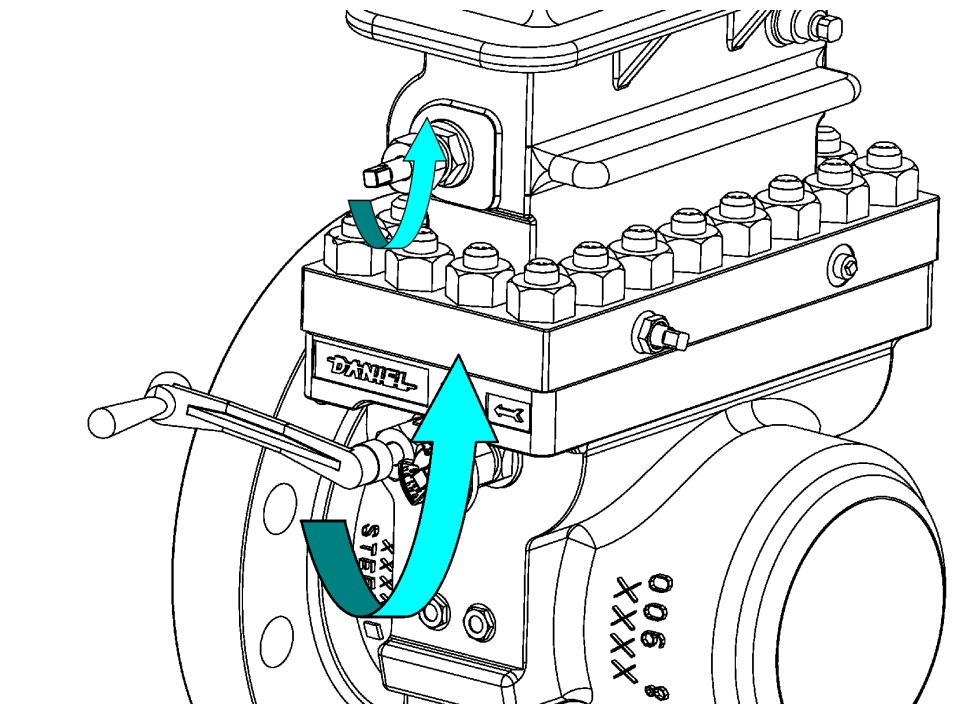

6. Move the Operating Wrench (2) from the Lower Plate Carrier Shaft (6) located in the Body (4) on the Upper Plate Carrier Shaft (7) located in the Top (14).

Figure 4-12: Step 6

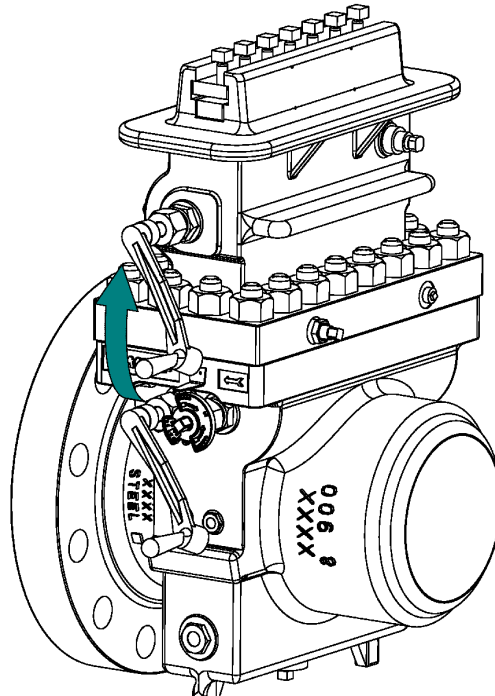

7. Rotate the Upper Plate Carrier Shaft (7) located in the Top (14) until the Plate Carrier (8DM or 8DMC) stops against the Sealing Bar (9, 9HP).

Figure 4-13: Step 7

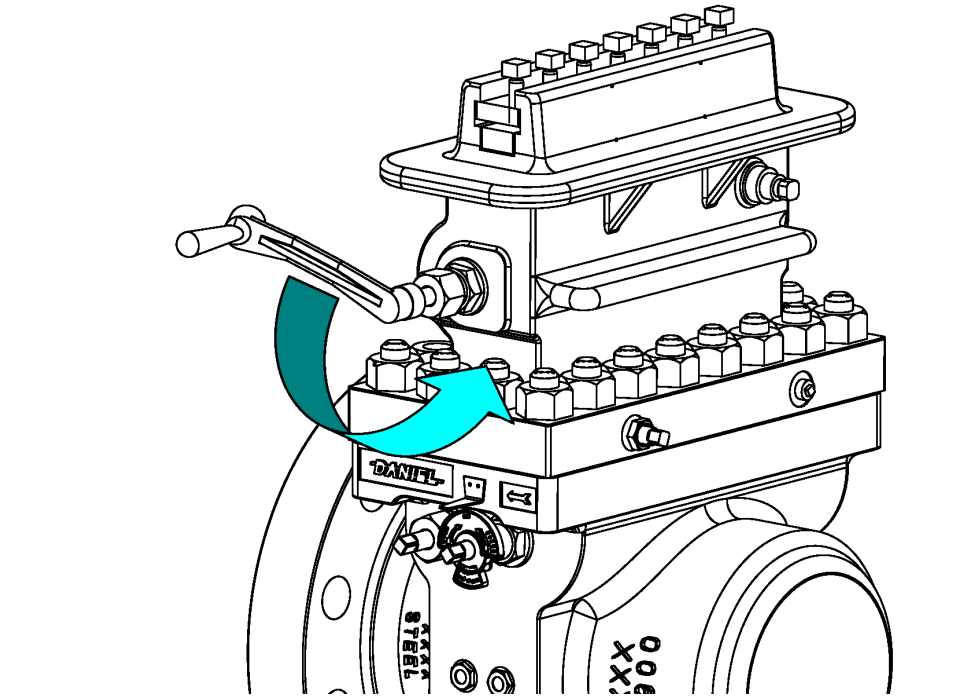

8. Close the Equalizer Valve (1) with the Operating Wrench (2).

Figure 4-14: Step 8

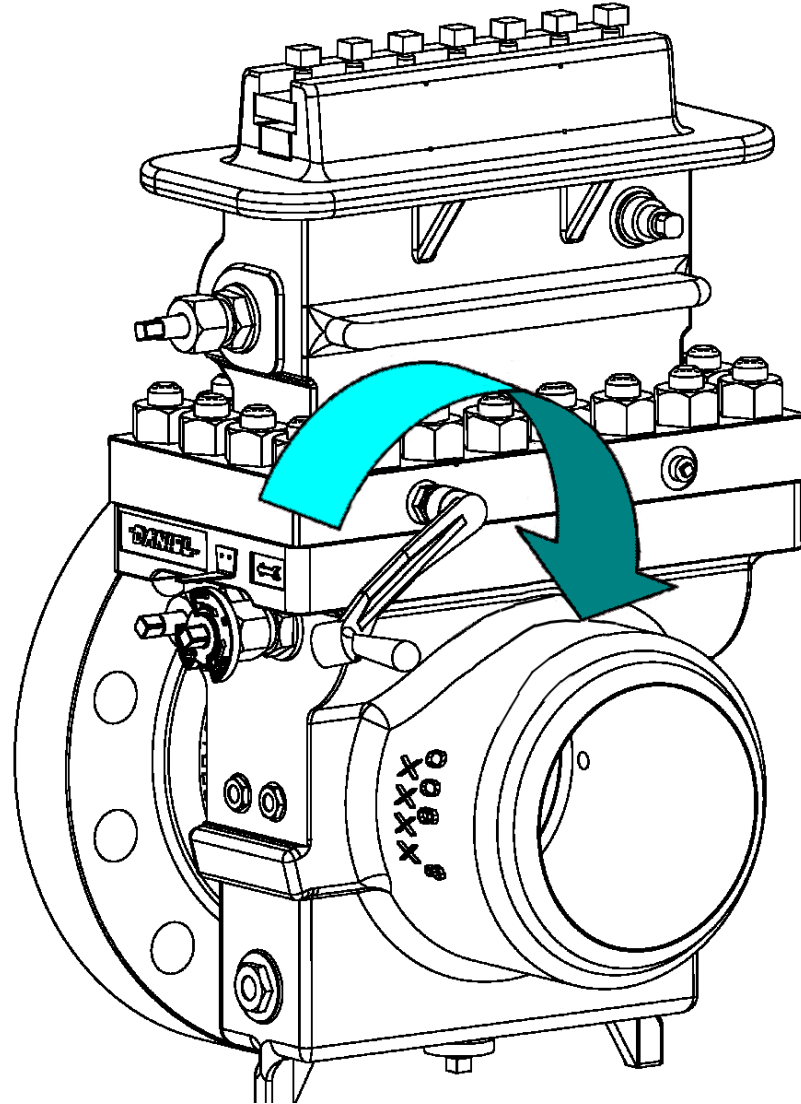

9. Using the Operating Wrench (2) rotate the Slide Valve Shaft (5) until it stops and the CLOSED position specified on the Indicator Plate (5A) is in line with the Indicator Pointer (5B).

Figure 4-15: Step 9

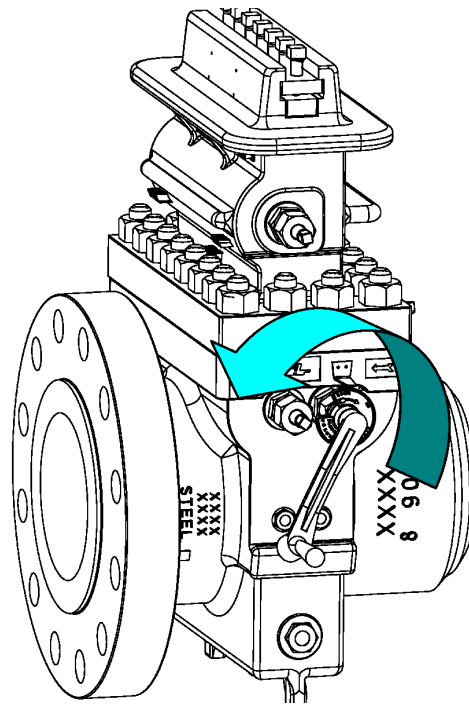

10. Open the Bleeder Valve (10B) with the Operating Wrench (2).

Figure 4-16: Step 10

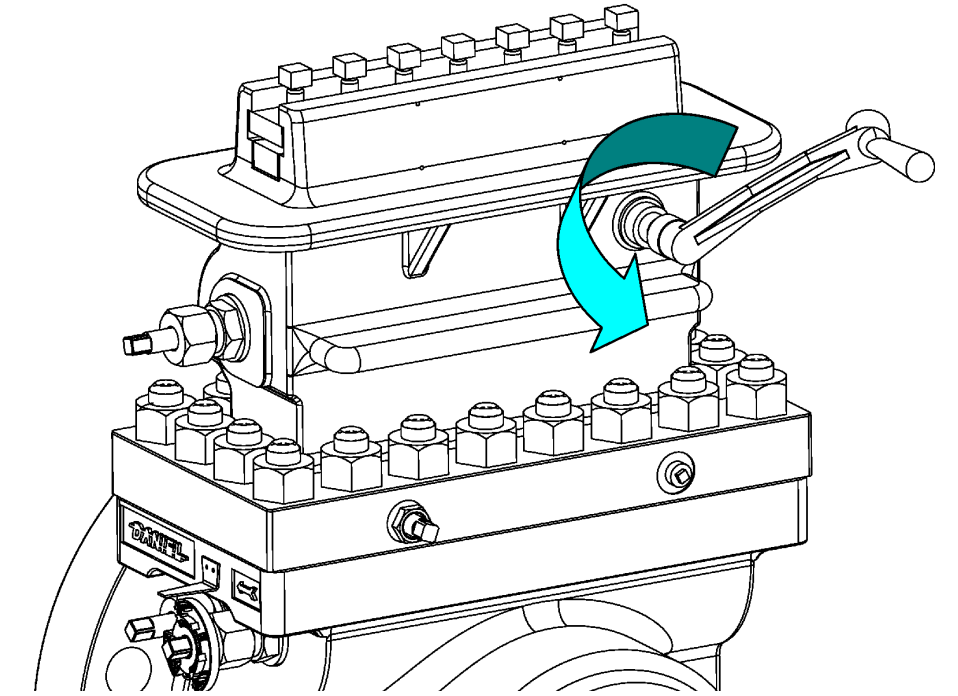

⚠ WARNING

PRESSURIZED FLUID HAZARD

When opening the bleeder valve (10B) or venting the Top (14) through the bleeder valve (10B), direct the released pressurized fluid away from any individual in accordance with local environment regulations to a safe area.

The bleeder valve (10B) releases pressurized fluid that may cause contamination and/or accumulation of volatile gas mixtures. Failure to comply may cause death or serious injury.

NOTICE

The pressure contained in the Top (14) must be lowered to ambient pressure in order to begin any Orifice Plate (13) procedures. When lowering the pressure in the Top (14), the operator must direct fluid or gas escaping from the Top (14) to a safe area away from the operator, and in accordance with local environmental regulations.

Steps 11 and 12 are **ONLY** required for the Seniors equipped with grease assisted, metal-to-metal slide valves. Personnel operating the Senior equipped with O-ring seal "soft seat" design slide valves skip to step 13.

11. Remove the stem from the Grease Gun (23) with the Operating Wrench (2) and insert a lubricant stick into the Grease Gun (23).

Figure 4-17: Step 11

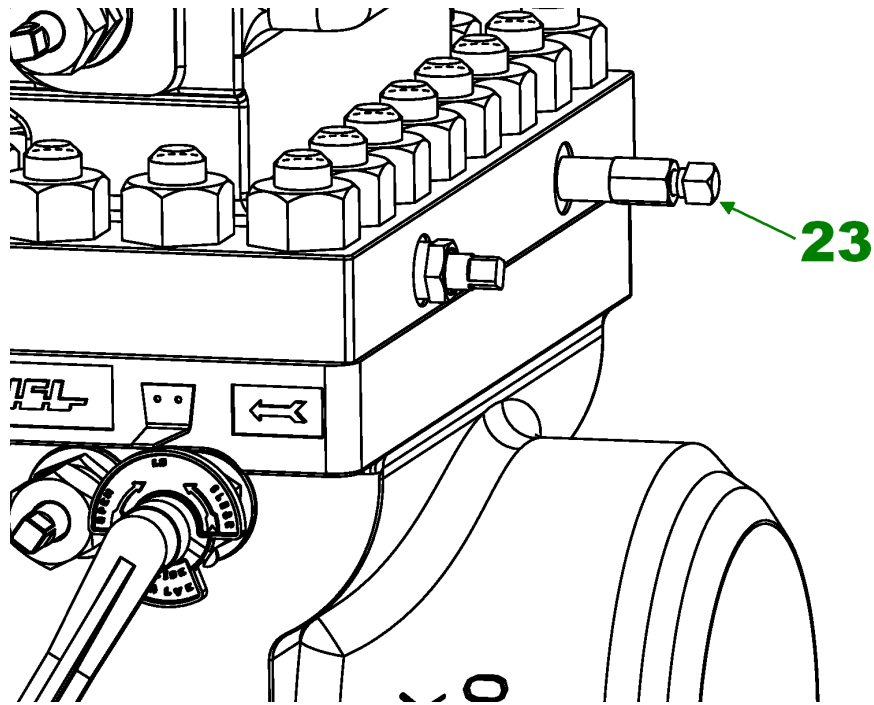
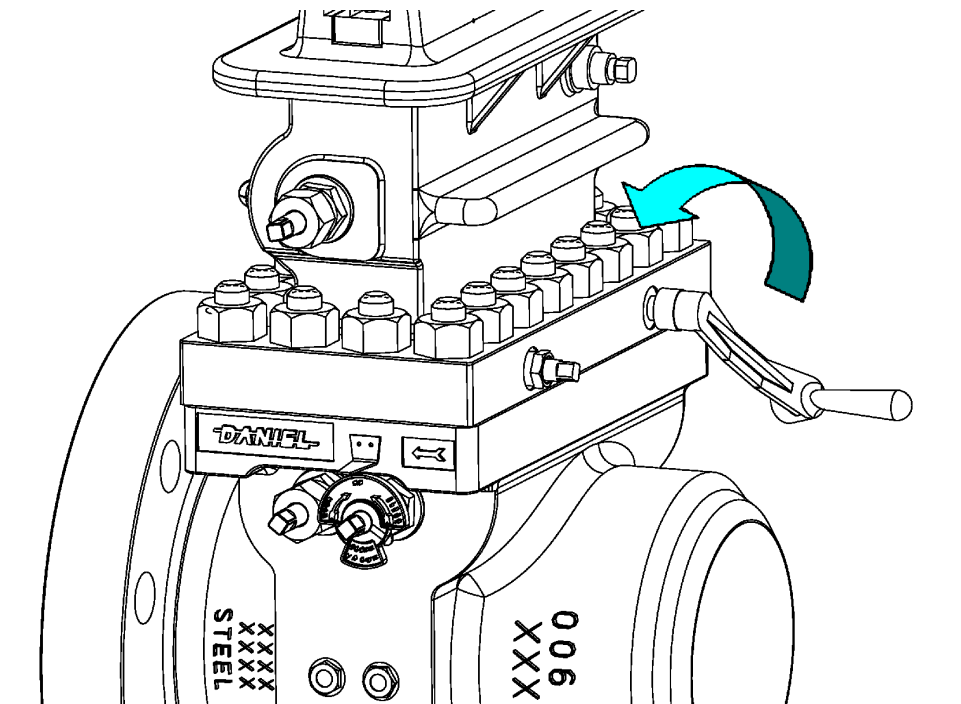

Figure 4-18: Step 11A



 **WARNING**

PRESSURIZED FLUID HAZARD

Using the Grease Gun (23), inject grease into the slide valve seat channels at a rate of 4 to 6 turns per minute and only under the following conditions:

- Bleeder Valve is open.
- Sealing bar/Clamping bar is in place and tight.

Injection of the grease at a faster rate will lead to the separation of the valve strip from the valve seat, resulting in release of pressurized fluid which may cause death or serious injury.

12. Return the stem to the Grease Gun (23) and begin turning it clockwise by hand into the Grease Gun (23) until resistance is felt. Once this is done, use the supplied Operating Wrench (2) to continue to turn the stem clockwise, at a rate of 4 to 6 turns per minute.

Figure 4-19: Step 12

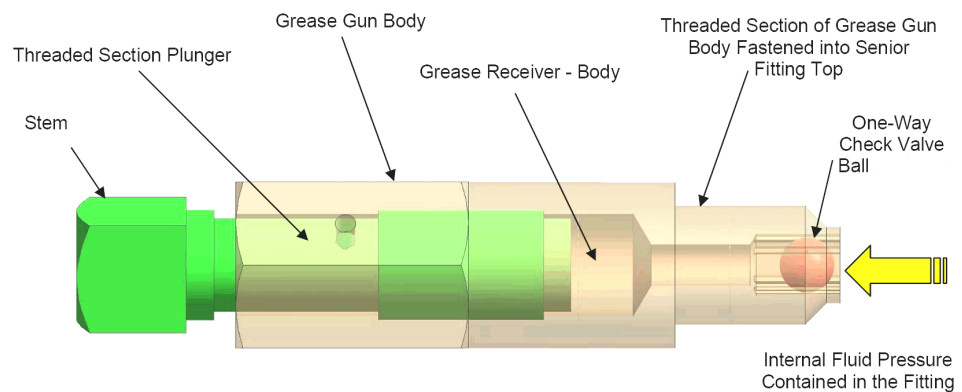

Grease Gun (23)

Important

By turning the stem of the Grease Gun (23) at a rate of 4 to 6 turns per minute, the lubricant is forced through the Slide Valve Seat (18) channels at a rate that allows the lubricant to travel freely, yet not separate the valve strip from the valve seat. This method will keep fresh grease in the lubrication passages.

If the addition of grease does not reduce the flow from the open Bleeder Valve (10B) to zero, follow these steps:

- Close the Bleeder Valve (10B),
- Open the Equalizer Valve (1), and move the Slide Valve Shaft (5) from the CLOSED to the OPEN position, and back to the CLOSED position, repeating this action several times.
- Return the Slide Valve Shaft (5) back to the CLOSED position.
- Close the Equalizer Valve (1) and repeat the lubrication process.
- Open the Bleeder Valve (10B).

If leakage is still present, close the Bleeder Valve (10B) and leave the Slide Valve Shaft (5) in the CLOSED position and schedule maintenance on the Senior.

13. Monitor the fluid/gas pressure in the Top (14) until it is equal to ambient conditions.

Important

Once the Top (14) is equal to ambient conditions, the 15 minute countdown to remove and install the Orifice Plate Carrier (8DM or 8DMC) begins.

Although the fluid pressure contained in the Top (14) is reduced to ambient conditions in the following operations, there still remain remnants of the fluid in

that chamber. The operator must employ a system to address the remaining fluid based upon the fluid's chemical composition and toxicity.

! WARNING

RELEASE OF FLUIDS OR COMPONENTS HAZARD

The Clamping Bar (12 or 12HP) may not be securely in place. Sudden release of fluid or internal components may occur. Never place the Operating Wrench (2) on the Slide Valve Shaft (5), or any body part in front of the top opening in the Top (14).

Failure to comply may cause death or serious injury.

14. Loosen each Clamping Bar Screw (11) located on the Clamping Bar (12 or 12HP) approximately two turns with the Operating Wrench (2).

Figure 4-20: Step 14

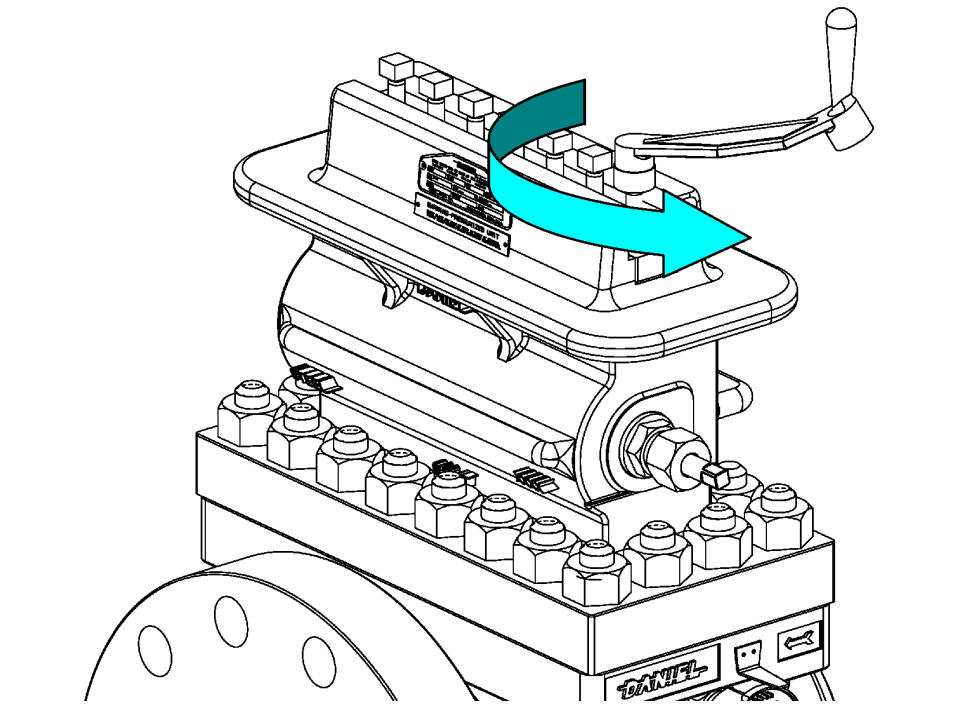

15. Once the Clamping Bar Screws (11) are loose, rotate the Upper Plate Carrier Shaft (7) located in the Top (14) with the Operating Wrench (2), until the Plate Carrier (8DM or 8DMC) taps against the Sealing Bar (9 or 9HP) freeing it from the Top (14).

Figure 4-21: Step 15

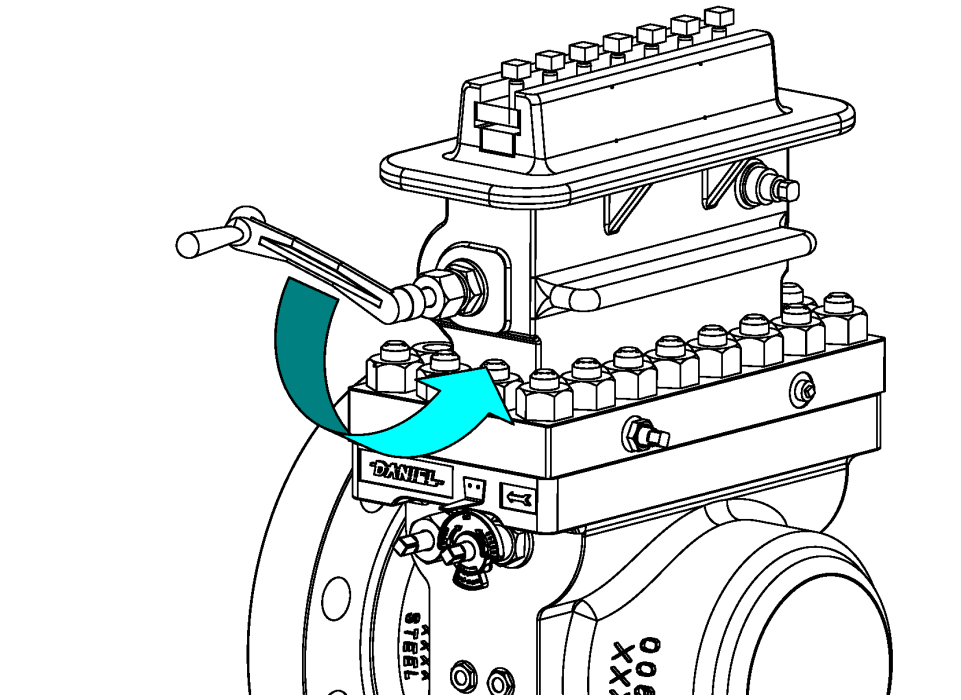

16. Slide the Clamping Bar (12 or 12HP) containing the Clamping Bar Screws (11), the Sealing Bar (9 or 9HP) from the Top (14).

Figure 4-22: Step 16-17

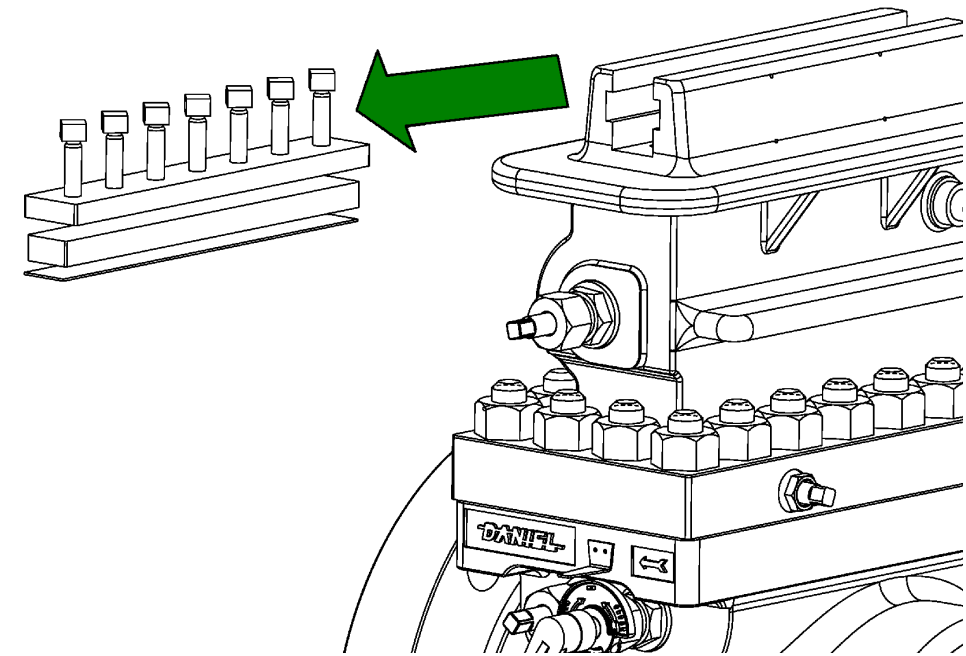

17. Remove the Sealing Bar Gasket (9A, 9A-HP or 9CF) from the Top (14).

18. Rotate the Upper Plate Carrier Shaft (7), located in the Top (14) with the Operating Wrench (2), until the Plate Carrier (8DM or 8DMC) extends outside of the Top (14) and continue to rotate the Upper Plate Carrier Shaft (7) until the Upper Plate Carrier Shaft (7) gears and the Plate Carrier (8DM or 8DMC) gear rack ratchet.

Figure 4-23: Step 18

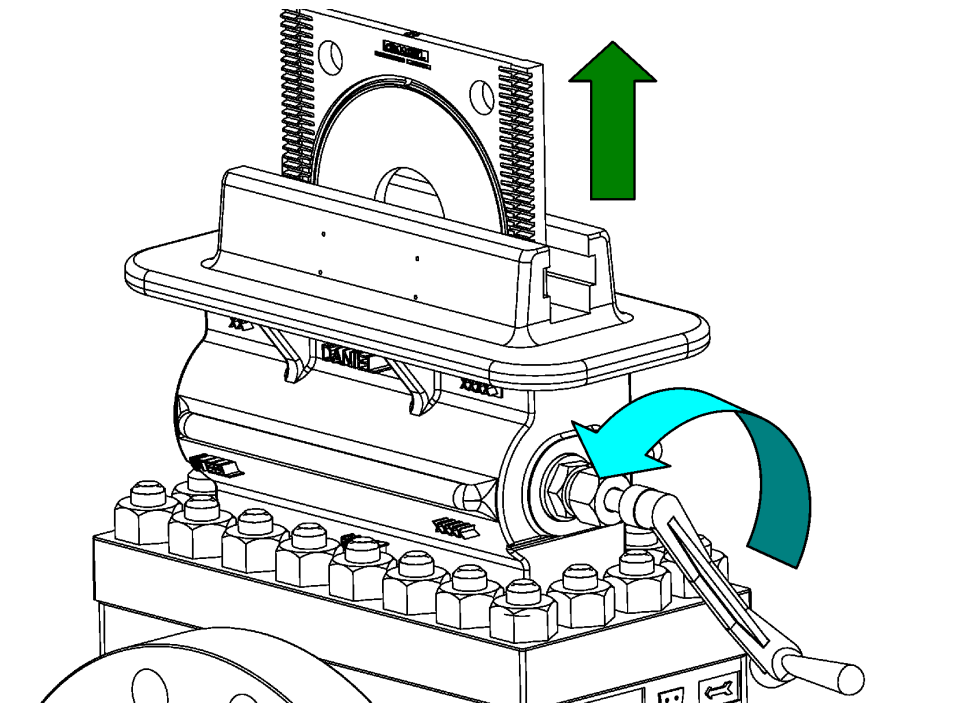

19. Remove the Orifice Plate Carrier (8DM or 8DMC) from the Top (14) and perform the scheduled work on the Orifice Plate (13) and Orifice Plate Carrier (8DM or 8DMC).
20. Insert the Orifice Plate Carrier (8DM or 8DMC) into the Top (14) until the Upper Plate Carrier Shaft (7) gears and the plate carrier gear rack mesh.
21. With the Operating Wrench (2), rotate the Upper Plate Carrier Shaft (7), located in the Top (14), a minimum of one quarter turns OPPOSITE of the direction required to lower the Orifice Plate Carrier (8DM or 8DMC) into the Top (14). This action allows the Orifice Plate Carrier (8DM or 8DMC) to properly "align" the Orifice Plate Carrier (8DM or 8DMC) with the plate carrier shaft.

Important

Align the Orifice Plate Carrier (8DM or 8DMC) with the Upper Plate Carrier Shaft (7). Failure to do so may damage the Senior.

! WARNING

PRESSURIZED FLUID HAZARD

Do not lower the Plate Carrier (8DM or 8DMC) directly onto the slide valve as it may damage the sealing features and release pressurized fluid.

Damaging the sealing features may cause contamination and/or accumulation of volatile gas mixtures, resulting in death or serious injury and equipment damage.

22. Once the Orifice Plate Carrier (8DM or 8DMC) is aligned, rotate the Upper Plate Carrier Shaft (7) with the Operating Wrench (2), in a direction to lower the Orifice Plate Carrier (8DM or 8DMC) into the Top (14) until all of the Orifice Plate Carrier (8DM or 8DMC) is below the Sealing Bar Gasket (9A, 9A-HP or 9CF) surface.

Figure 4-24: Step 22

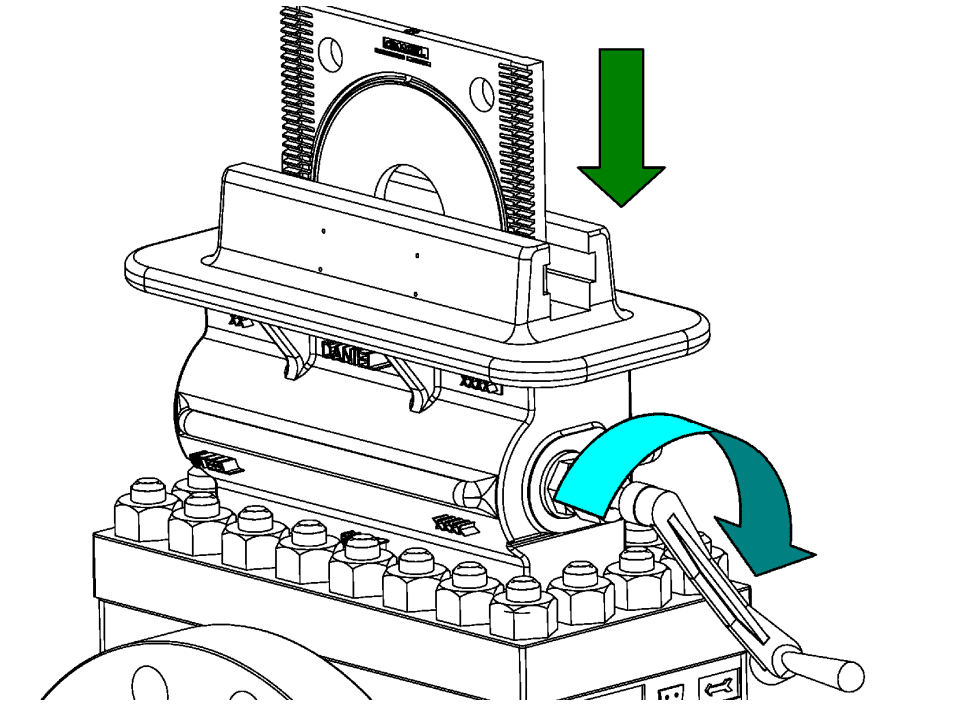

⚠ WARNING

EXPLOSION HAZARD

Ensure that the Sealing Bar Gasket (9A, 9A-HP or 9CF), the Sealing Bar (9 or 9HP) and the Clamping Bar (12 or 12HP) provide a pressure barrier between the line pressure and the atmosphere.

Failure to properly install these parts may result in explosive separation of components resulting in death or serious injury.

23. Install a new Sealing Bar Gasket (9A, 9A-HP or 9CF) on to the Top (14).

Figure 4-25: Steps 23 - 24

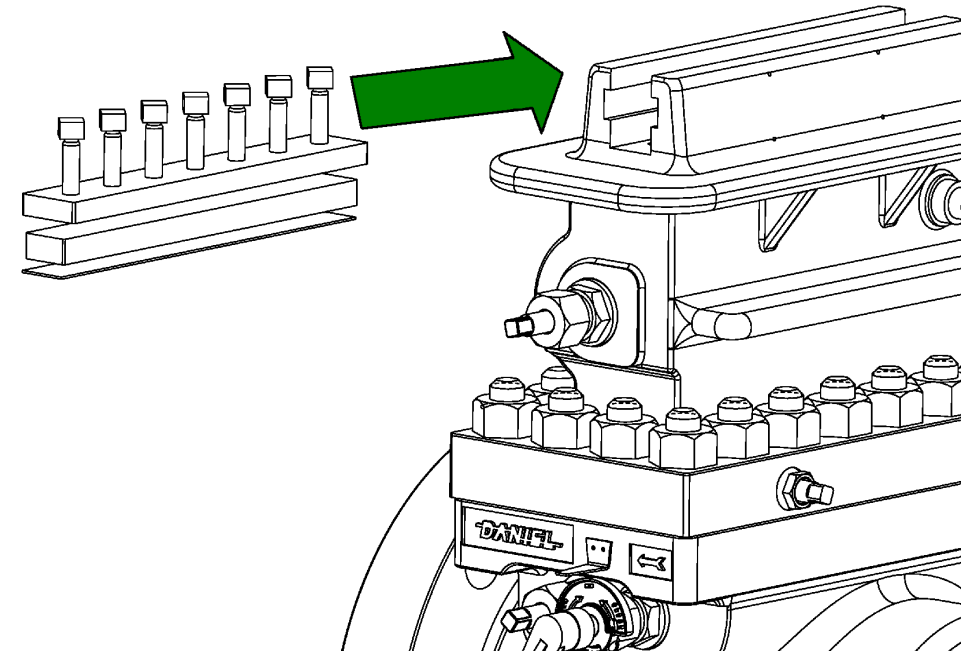

24. Install the Sealing Bar (9 or 9HP) and the Clamping Bar (12 or 12HP) on to the Top (14).

25. Tighten each Clamping Bar Screw (11), located on the Clamping Bar (12 or 12HP), (Reference: [Torque information](#))

Figure 4-26: Step 25

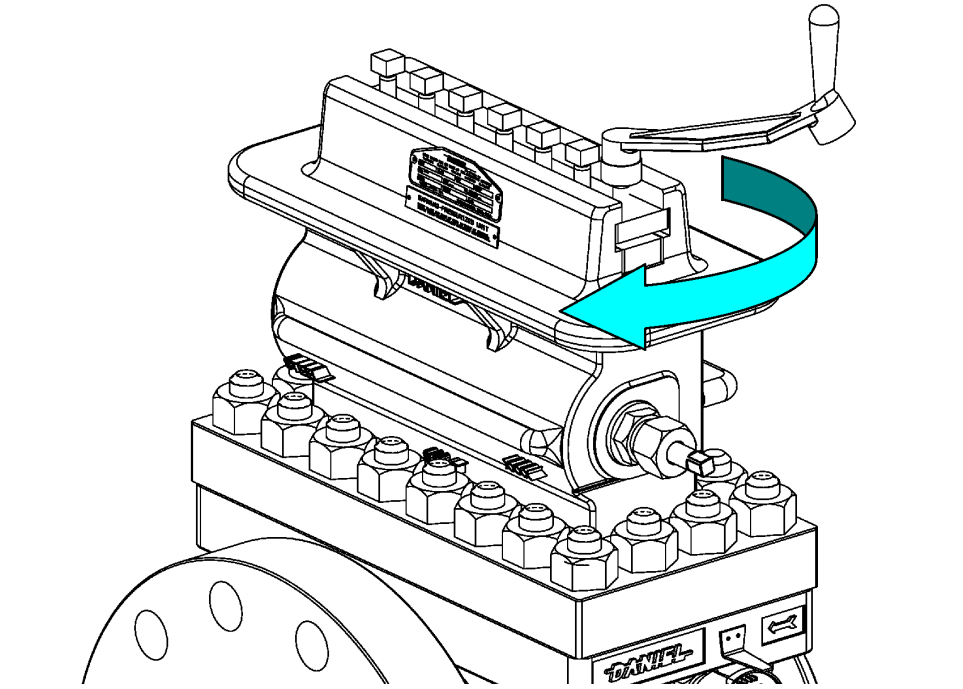

26. Close the Bleeder Valve (10B).

Figure 4-27: Step 26

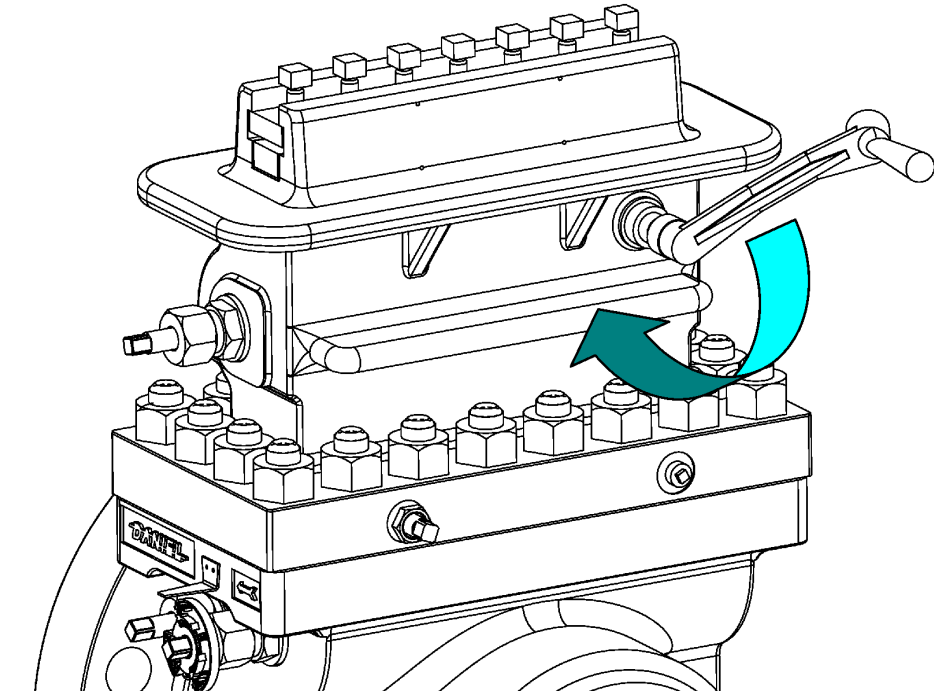

Important

After closing the Bleeder Valve (10B), the 15 minute countdown to remove and install the Orifice Plate Carrier (8DM or 8DMC) ends.

27. Open the Equalizer Valve (1) one-half to two turns with the Operating Wrench (2).

Figure 4-28: Step 27

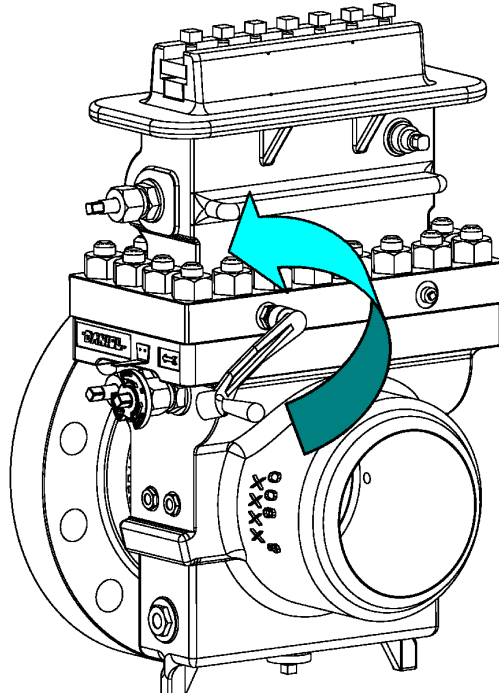

28. Wait several seconds for the Top (14) to reach pressure equilibrium with the line pressure contained in the Body (4).

Figure 4-29: Step 28

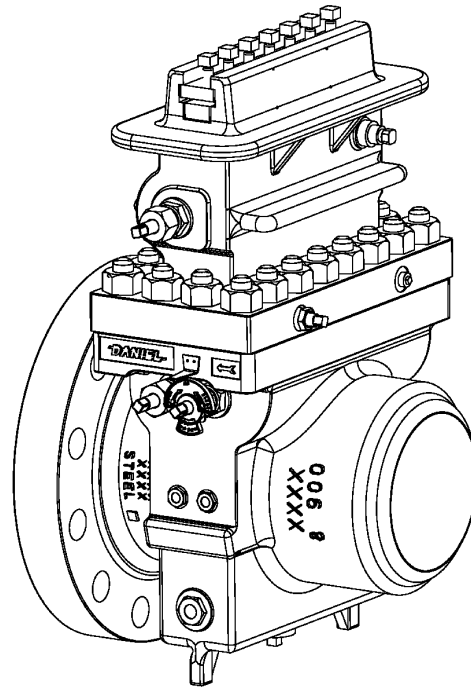

29. Using the Operating Wrench (2), rotate the Slide Valve Shaft (5) to the OPEN position.

Figure 4-30: Step 29

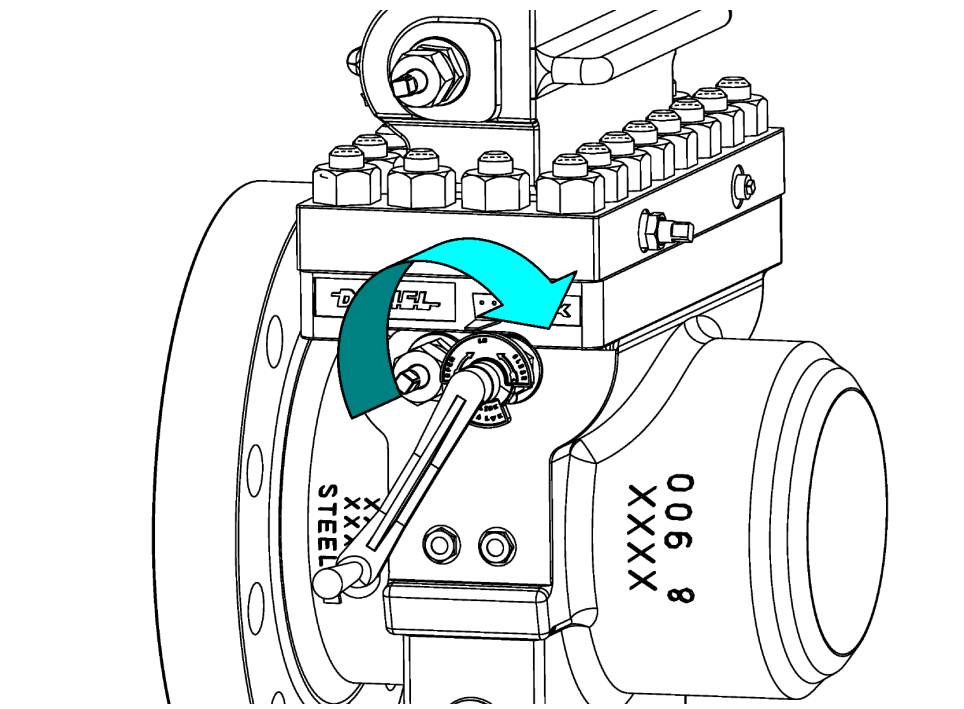

30. Rotate the Upper Plate Carrier Shaft (7) with the Operating Wrench (2) in the direction to lower the Orifice Plate Carrier (8DM or 8DMC) into the Body (4).

Figure 4-31: Step 30

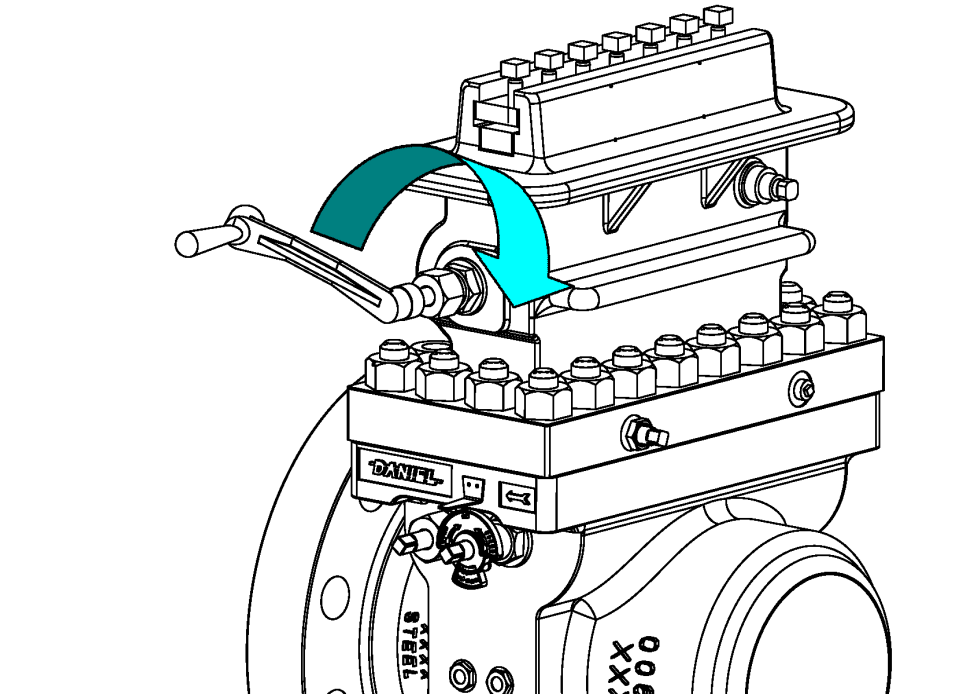

31. Rotate the Lower Plate Carrier Shaft (6) with the Operating Wrench (2) until the Orifice Plate Carrier (8DM or 8DMC) cannot be lowered further.

Figure 4-32: Step 31

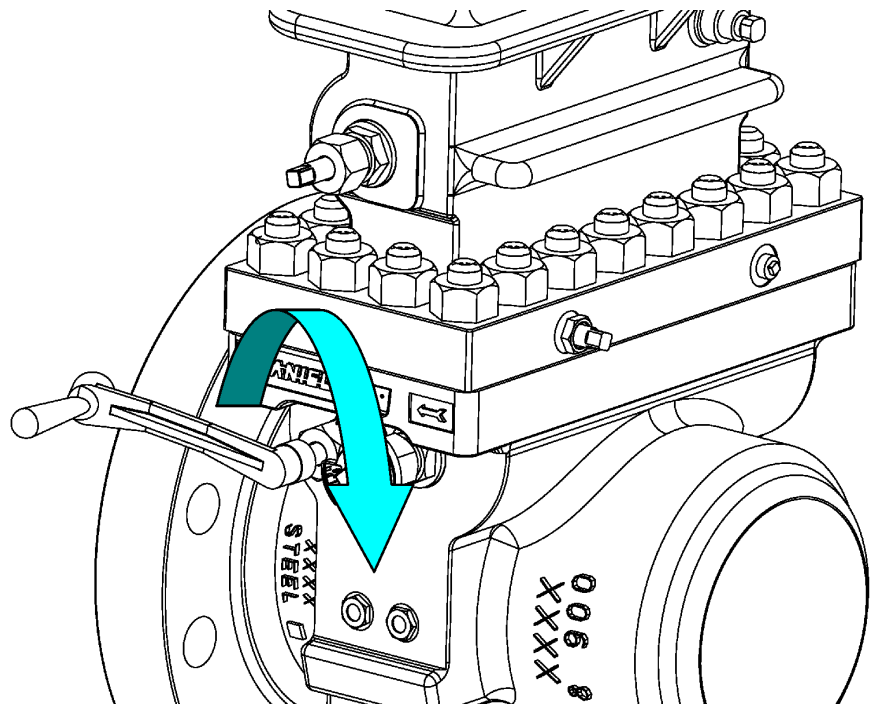

Important

Resistance to turning will be present when the Orifice Plate Carrier (8DM or 8DMC) is approaching its proper measurement position due to friction between the Senior Body (4) and the Orifice plate seal (8E-DSC, etc.).

32. Once the Orifice Plate Carrier (8DM or 8DMC) is positioned in the Body (4), turn the Slide Valve Shaft (5) using the Operating Wrench (2) into the CLOSED position.

Figure 4-33: Step 32

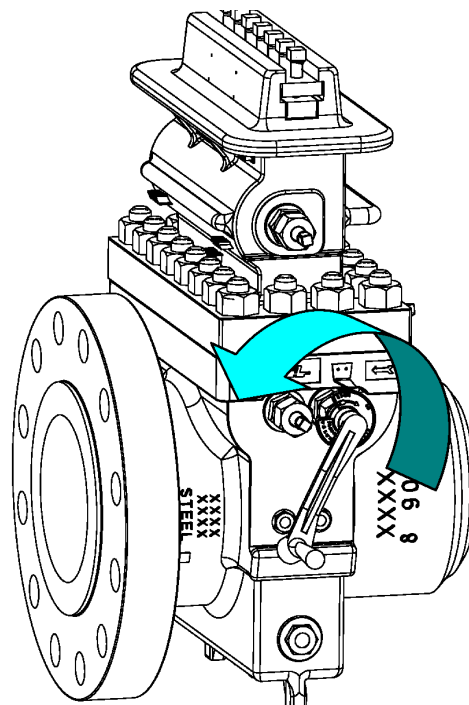

33. Close the Equalizer Valve (1).

Figure 4-34: Step 33

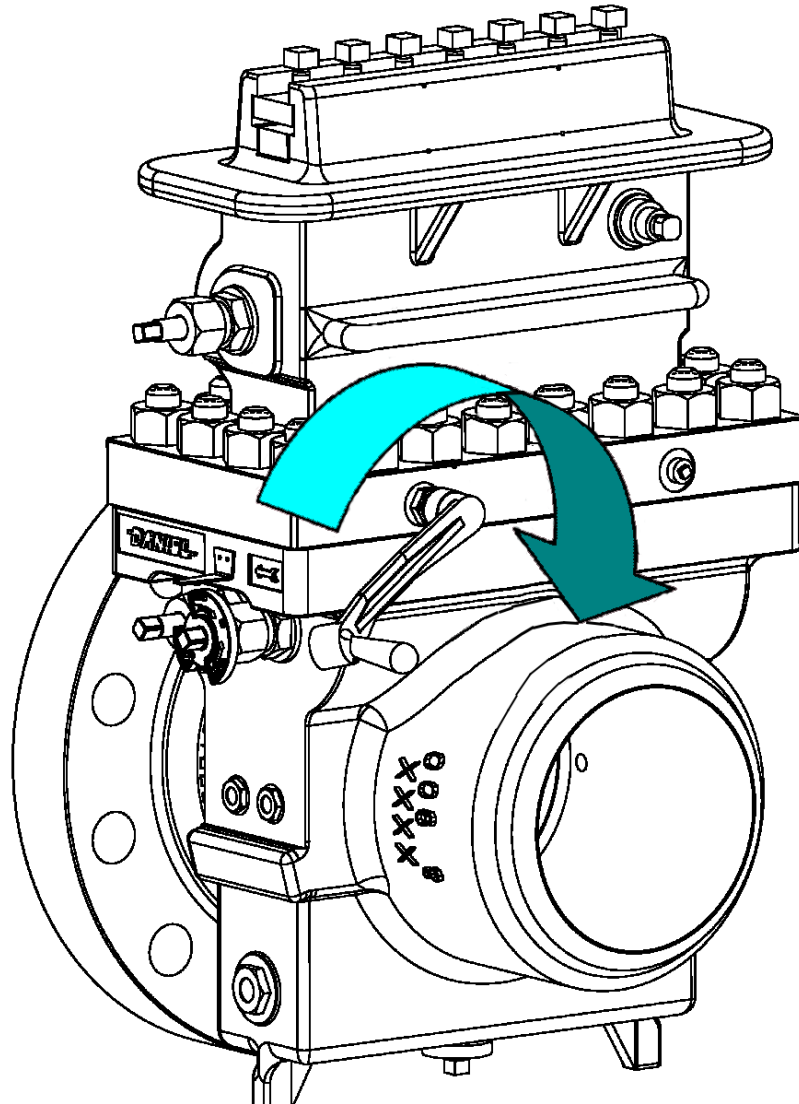

! WARNING

PRESSURIZED FLUID HAZARD

When opening the bleeder valve (10B) or venting the Top (14) through the bleeder valve (10B), direct the released pressurized fluid away from any individual in accordance with local environment regulations to a safe area.

The bleeder valve (10B) releases pressurized fluid that may cause contamination and/or accumulation of volatile gas mixtures. Failure to comply may cause death or serious injury.

34. Open the Bleeder Valve (10B) to vent the Top (14).

Figure 4-35: Step 34

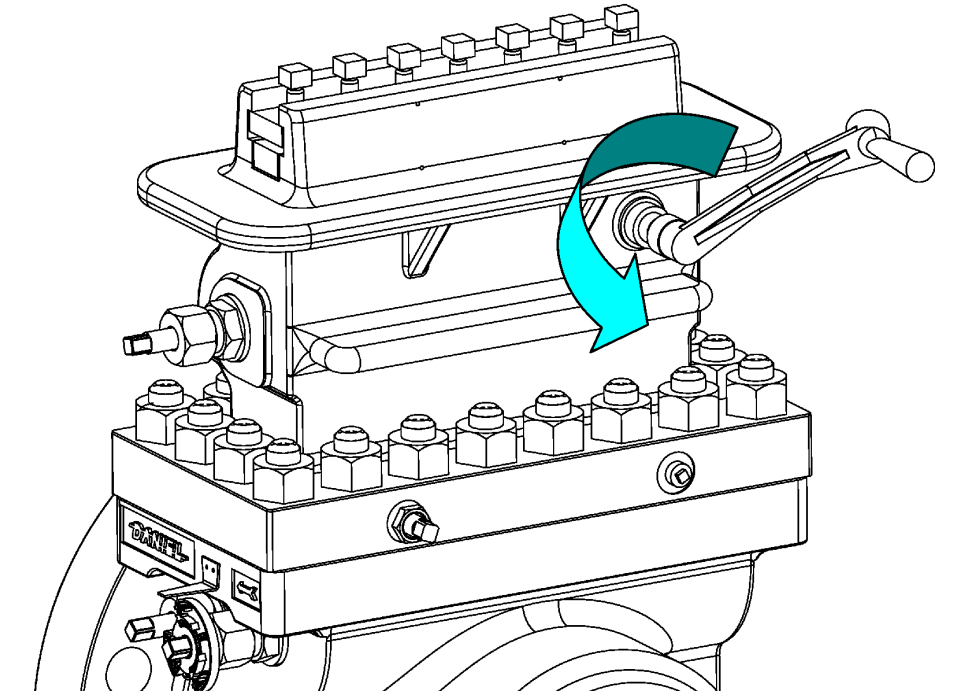

Steps 35 and 36 are ONLY required for Seniors equipped with grease assisted, metal-to-metal slide valves. Personnel operating the Daniel Senior Orifice Fittings equipped with O-Ring seal "soft seat" design slide valves skip to step 37.

35. Remove the stem from the Grease Gun (23) with the Operating Wrench (2) and insert a lubricant stick into the Grease Gun (23).

Figure 4-36: Step 35

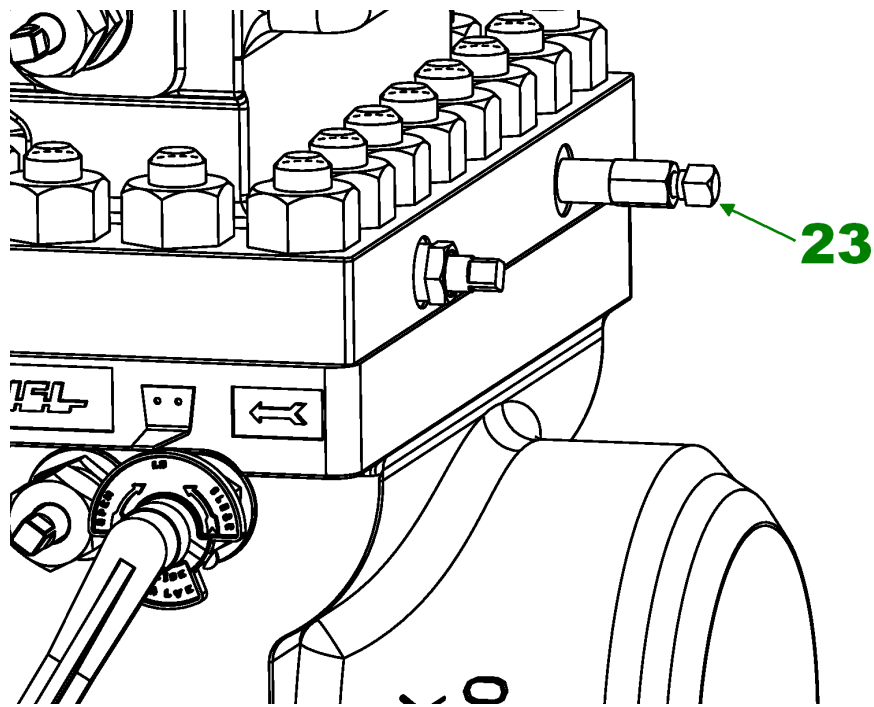
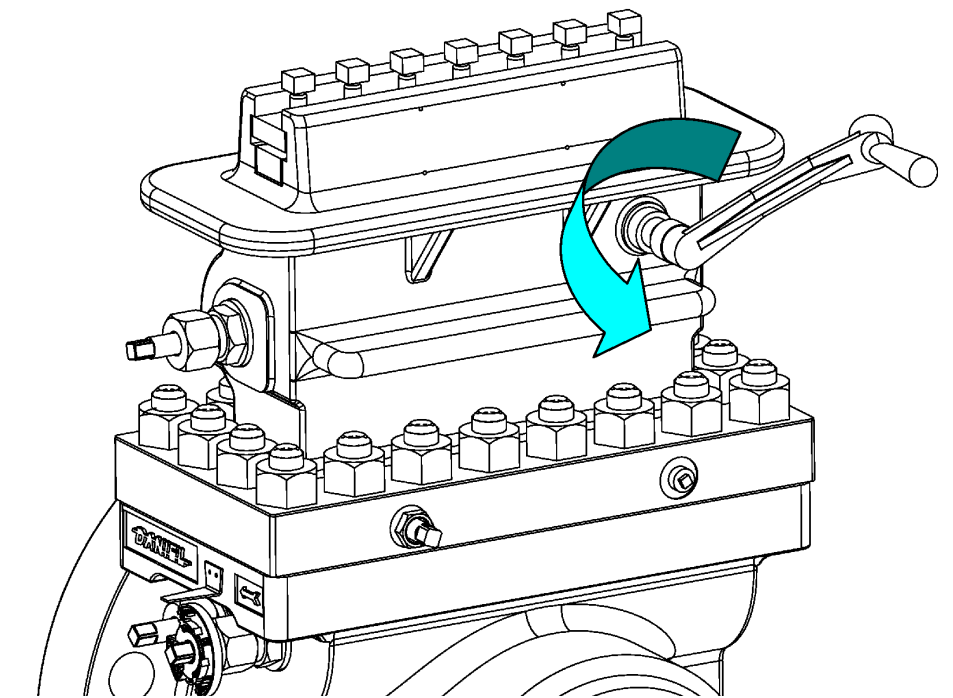

Figure 4-37: Step 35A



 **WARNING****PRESSURIZED FLUID HAZARD**

Using the Grease Gun (23), inject grease into the slide valve seat channels at a rate of 4 to 6 turns per minute and only under the following conditions:

- Bleeder Valve is open.
- Sealing bar/Clamping bar is in place and tight.

Injection of the grease at a faster rate will lead to the separation of the valve strip from the valve seat, resulting in release of pressurized fluid which may cause death or serious injury.

36. Return the stem to the Grease Gun (23) and begin turning it clockwise by hand into the Grease Gun (23) until resistance is felt. Once this is done, use the supplied Operating Wrench (2) to continue to turn the stem at a rate of 4 to 6 turns per minute.

Figure 4-38: Step 36

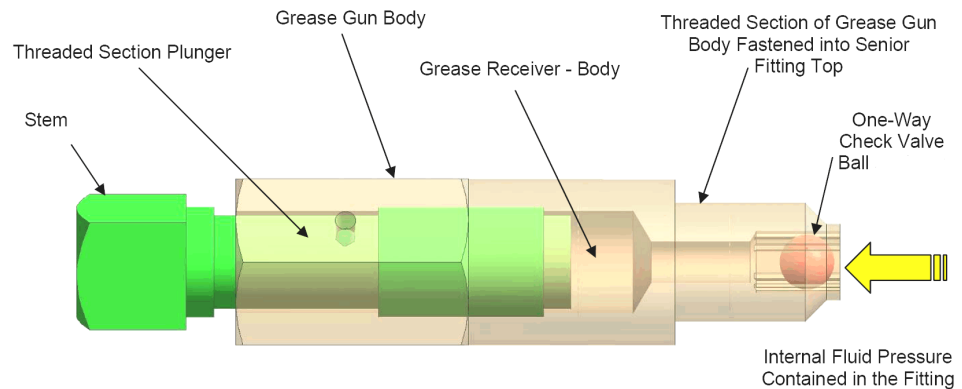

Grease Gun (23)

Important

By turning the stem of the Grease Gun (23) at a rate of 4 to 6 turns per minute, the lubricant is forced through the Slide Valve Seat (18) channels at a rate that allows the lubricant to travel freely, yet not separate the valve strip from the valve seat. This method will keep fresh grease in the lubrication passages.

If the addition of grease does not reduce the flow from the open Bleeder Valve (10B) to zero, follow these steps:

- Close the Bleeder Valve (10B),
- Open the Equalizer Valve (1), and move the Slide Valve Shaft (5) from the CLOSED to the OPEN position, and back to the CLOSED position, repeating this action several times.
- Return the Slide Valve Shaft (5) back to the CLOSED position.
- Close the Equalizer Valve (1) and repeat the lubrication process.
- Open the Bleeder Valve (10B).
- If leakage is still present, close the Bleeder Valve (10B) and leave the Slide Valve Shaft (5) in the CLOSED position and schedule maintenance on the Senior.
- Close the Bleeder Valve (10B).

37.

Figure 4-39: Step 37

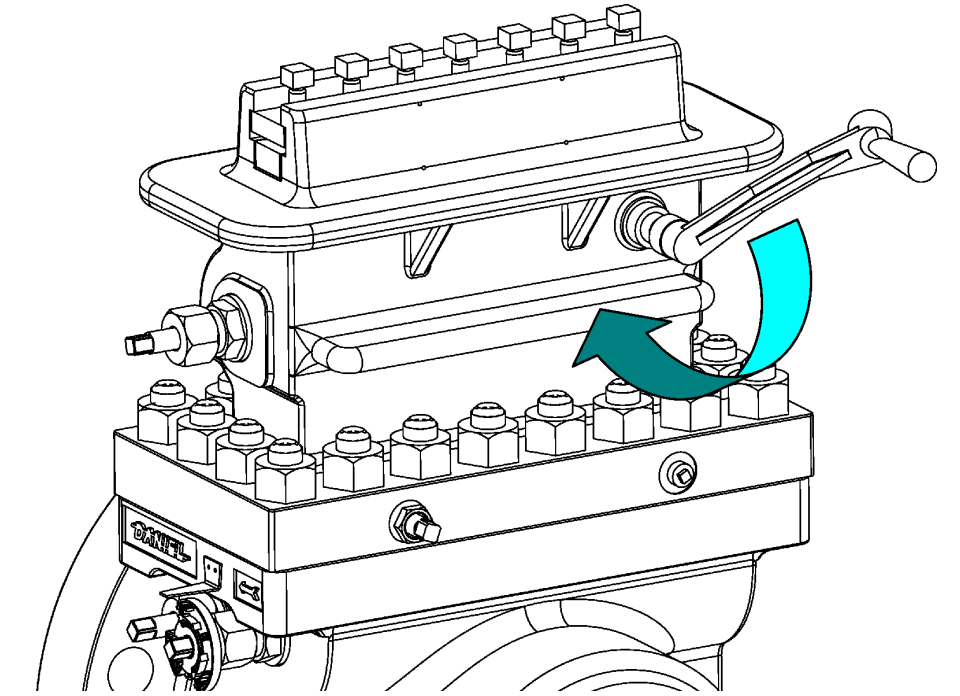

The Daniel Senior Orifice Fitting is now ready for measurement.

Requirements for “Extended time” procedure

This procedure is for the grease-assisted slide valves when the procedure takes over 15 minutes. However, it is acceptable for soft-seated valves. For Seniors equipped with an O-Ring (10E) soft seated valve, the operator may employ either the "QUICK CHANGE" procedure or the "EXTENDED TIME" procedure. However, for the Seniors equipped with a grease-assisted slide valve, the "QUICK CHANGE" procedure may be used only if it can be finished in less than 15 minutes.

WARNING

TOXIC EXPLOSION HAZARD

Do not perform any of the following steps if the Indicator Plate, the Indicator Pointer, or both are not assembled on the Senior. Call Flow Lifecycle Services for Daniel products for assistance in obtaining replacement components, and follow the instructions provided in [Commission the Daniel Senior Orifice Fitting](#).

Improper installation, maintenance or removal could result in explosive or toxic conditions resulting in death or serious injury.

NOTICE

Prior to performing any maintenance or Orifice Plate (13) installation and removal operations on the Senior, personnel must visually confirm the presence of the indicator Plate (5A) on the Slide Valve Shaft (5) and the Indicator Pointer (5B) on the Body (4). Both

the indicator plate and the indicator pointer must be installed to operate this equipment safely.

Figure 4-40: Indicator plate (5A) and pointer (5B)

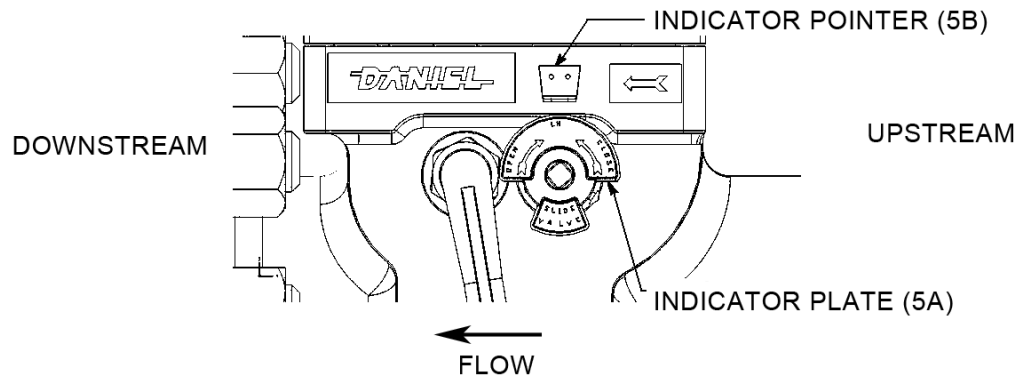

In preparation for the plate removal and installation process, the operator must evaluate the meter system to determine the amount of time between the Top (14) fluid evacuation and the plate change to the full replacement of the Clamping Bar (12 or 12HP), the Sealing Bar (9 or 9HP), and the Sealing Bar Gasket (9A, 9A-HP or 9CF) back on the Top (14).

If the operator determines that the time between the Top (14) fluid evacuation and plate change to the full replacement of the Clamping Bar (12 or 12HP), the Sealing Bar (9 or 9HP), and the Sealing Bar Gasket (9A, 9A-HP or 9CF) back on the Top (14) is less than 15 minutes, then the operator may use the "QUICK CHANGE" procedure.

If the operator determines that the time between the Top (14) fluid evacuation and the plate change to the full replacement of the Clamping Bar (12 or 12HP), the Sealing Bar (9 or 9HP), and the Sealing Bar Gasket (9A, 9A-HP or 9CF) back on the Top (14) is greater than 15 minutes, then the operator must use the "EXTENDED TIME" procedure.

If, for any reason, the operator cannot determine the total time between the Top (14) fluid evacuation and the plate change to the full replacement of the Clamping Bar (12 or 12HP), the Sealing Bar (9 or 9HP), and the Sealing Bar Gasket (9A, 9A-HP or 9CF) back on the Top (14), then the operator must use the "EXTENDED TIME" procedure.

! DANGER

FLUID EXPLOSION HAZARD

Follow the instructions below to avoid inadvertent or accidental opening of the slide valve and the propulsion of fluid or internal components from the Top (14).

Failure to comply will result in death or serious injury.

The following are the conditions required to start the removal procedure of the orifice plate:

- The Senior is operating at line pressure.
- The Plate Carrier (8DM or 8DMC) is located in the measurement position within the Body (4).
- The Indicator Pointer (5B) and the Indicator Plate (5A) are installed on the Senior.

- The Slide Valve Shaft (5) is in the CLOSED position.
- The Equalizer Valve (1) is in the CLOSED position.
- The Bleeder Valve (10B) is in the CLOSED position.
- The Sealing Bar Gasket (9A, 9A-HP or 9CF), the Sealing Bar (9 or 9HP), and the Clamping Bar (12 or 12HP) are fastened to the Top (14).
- Process temperature and ambient temperature values are within range of grease charts.
- Process pressure values are within the range of grease charts.

“Extended time” procedure

To remove the Orifice Plate (13) from the Daniel Senior Orifice Fitting, the operator must first balance the pressure between the Top (14) and the Body (4).

Procedure

1. Open the Equalizer Valve (1) one half to two full turns using the Operating Wrench (2).

Figure 4-41: Step 1

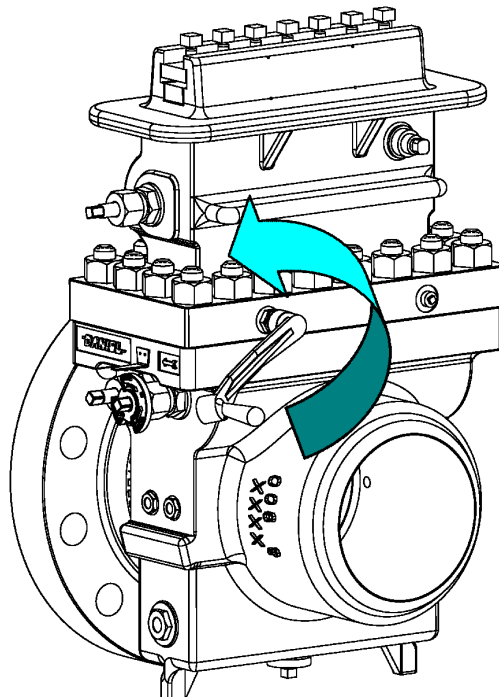

2. Wait several seconds while the pressure in the Top (14) equalizes to that of the Body (4).

Figure 4-42: Step 2

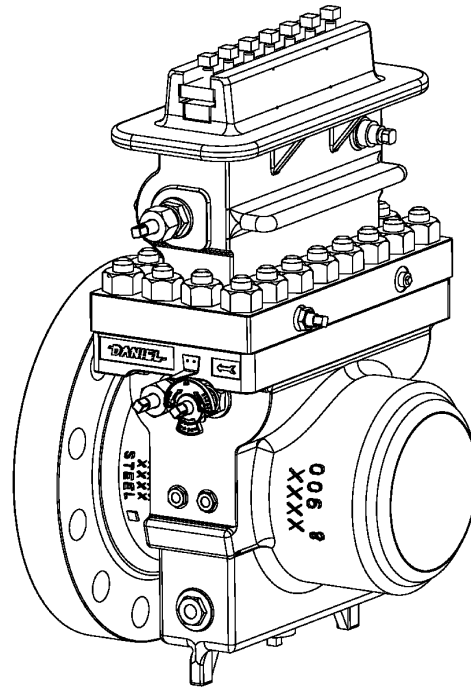

- Using the Operating Wrench (2) rotate the Slide Valve Shaft (5) until it stops and the OPEN position is specified on the Indicator Plate (5A) with the Indicator Pointer (5B).

Figure 4-43: Step 3

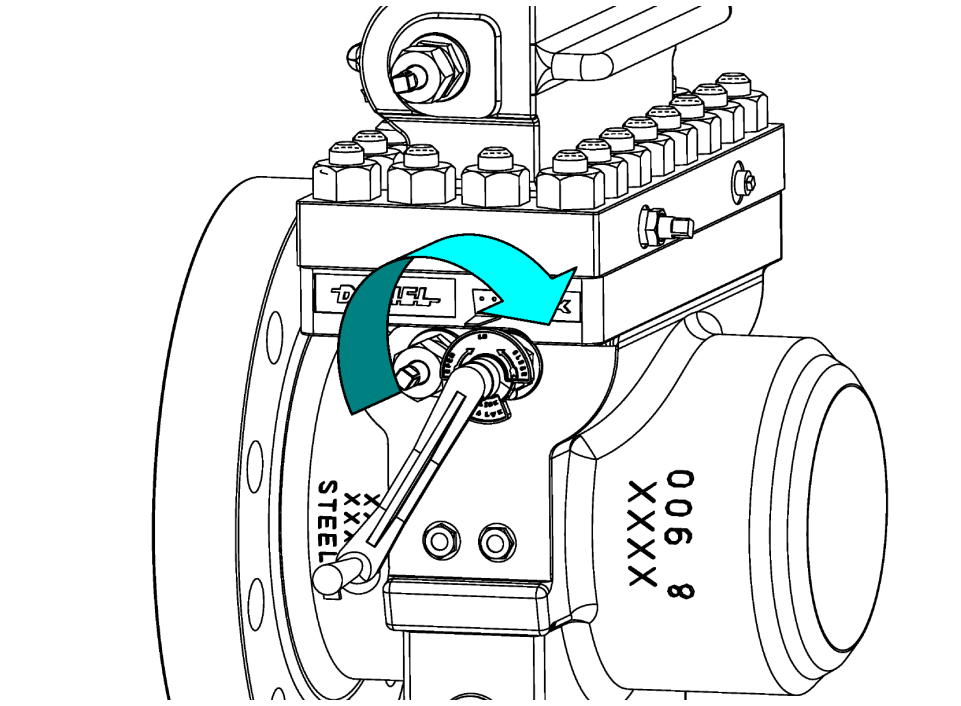

4. Rotate the Lower Plate Carrier Shaft (6), located on the Body (4), using the Operating Wrench (2) in a direction that will move the Plate Carrier (8DM or 8DMC) out of the Body (4) into the Top (14).

Figure 4-44: Step 4

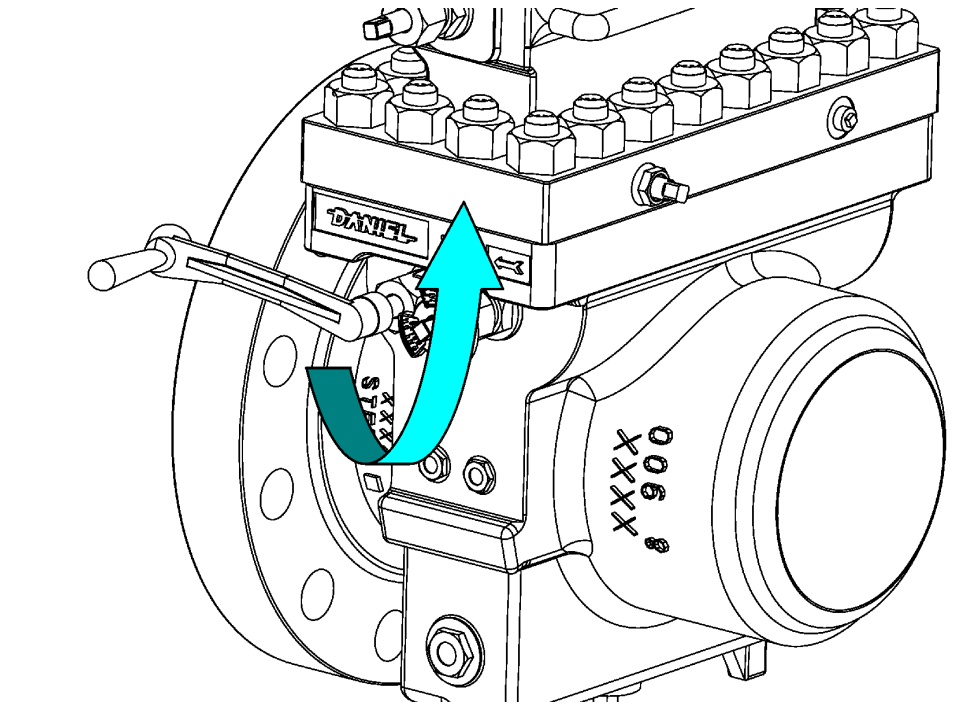

5. Continue to rotate the Lower Plate Carrier Shaft (6) located on the Body (4) until the Upper Plate Carrier Shaft (7) located in the Top (14) begins to rotate.

Figure 4-45: Step 5

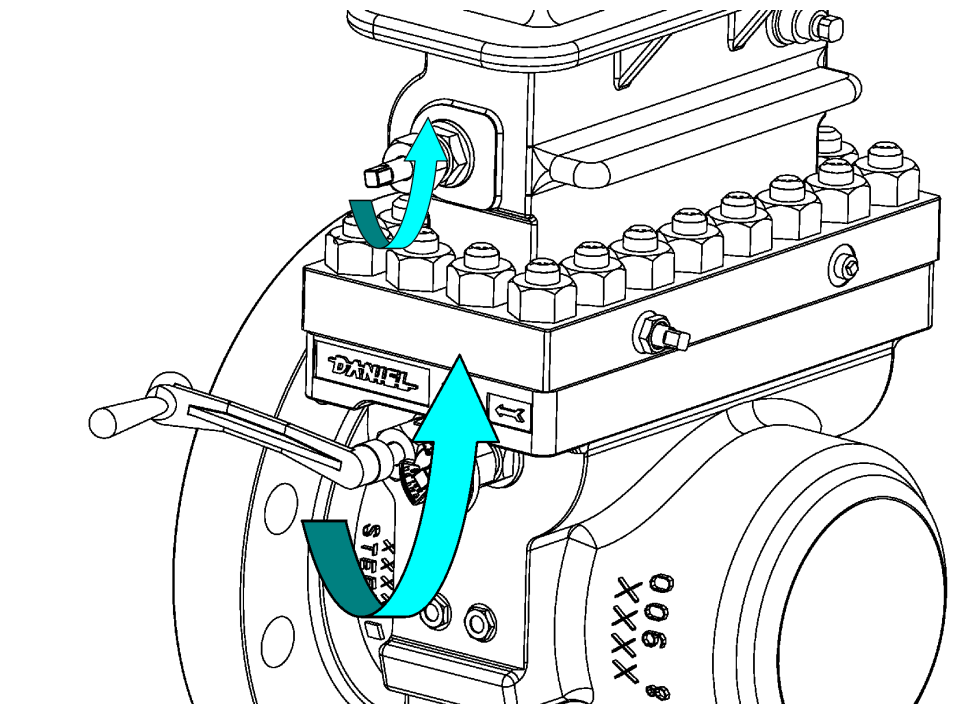

6. Move the Operating Wrench (2) from the Lower Plate Carrier Shaft (6) located in the Body (4) on the Upper Plate Carrier Shaft (7) located in the Top (14).

Figure 4-46: Step 6

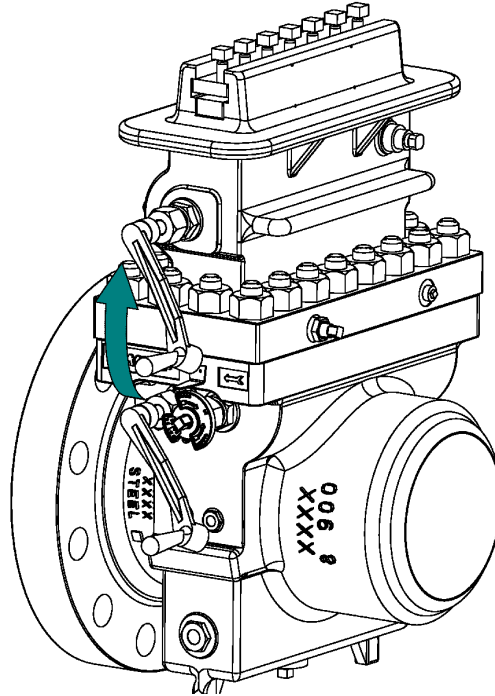

7. Rotate the Upper Plate Carrier Shaft (7) located in the Top (14) until the Plate Carrier (8DM or 8DMC) stops against the Sealing Bar (9 or 9HP).

Figure 4-47: Step 7

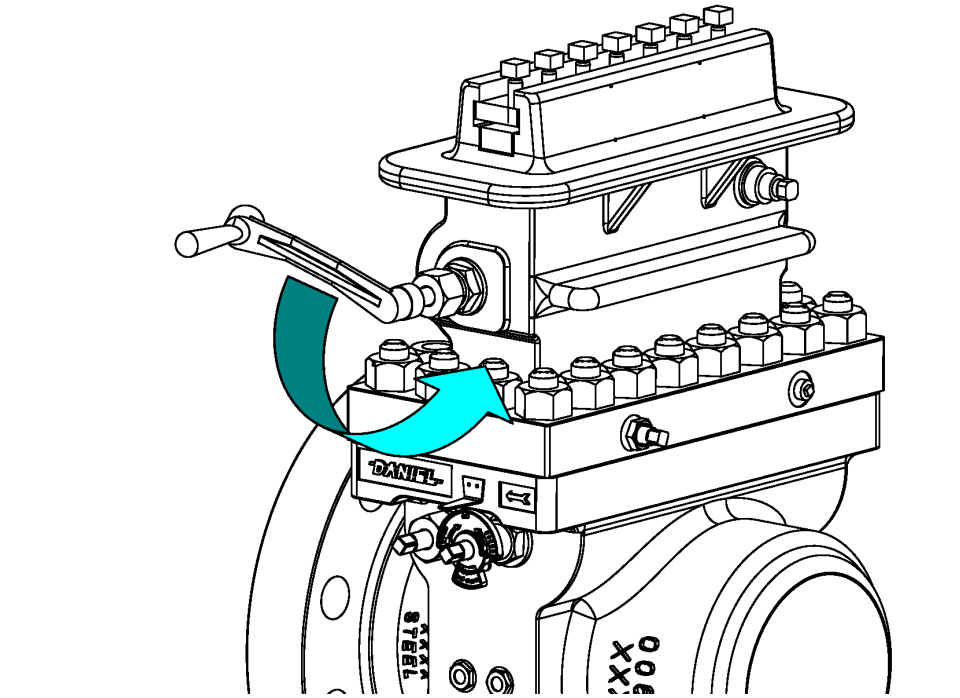

8. Close the Equalizer Valve (1) with the Operating Wrench (2).

Figure 4-48: Step 8

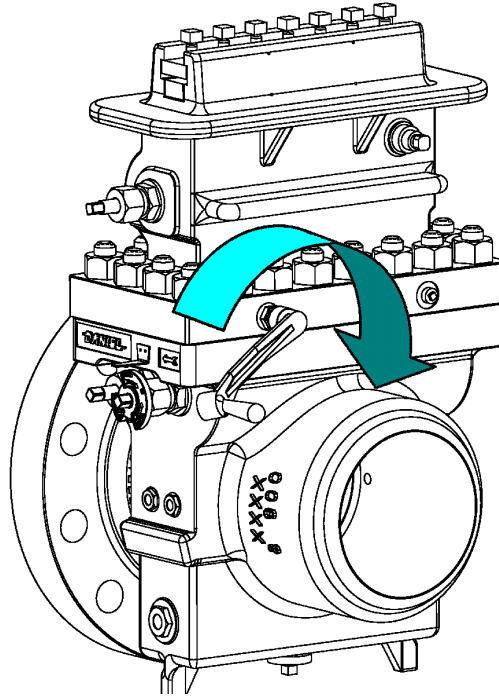

9. Using the Operating Wrench (2) rotate the Slide Valve Shaft (5) until it stops and the CLOSED position specified on the Indicator Plate (5A) is in line with the Indicator Pointer (5B).

Figure 4-49: Step 9

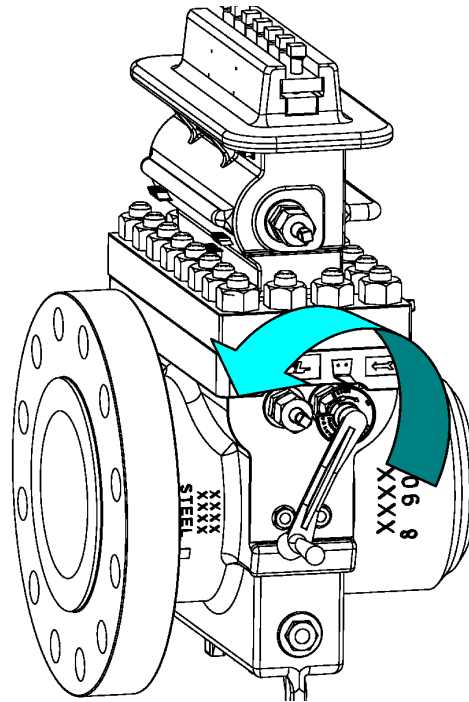

10. Open the Bleeder Valve (10B) with the Operating Wrench (2).

Figure 4-50: Step 10

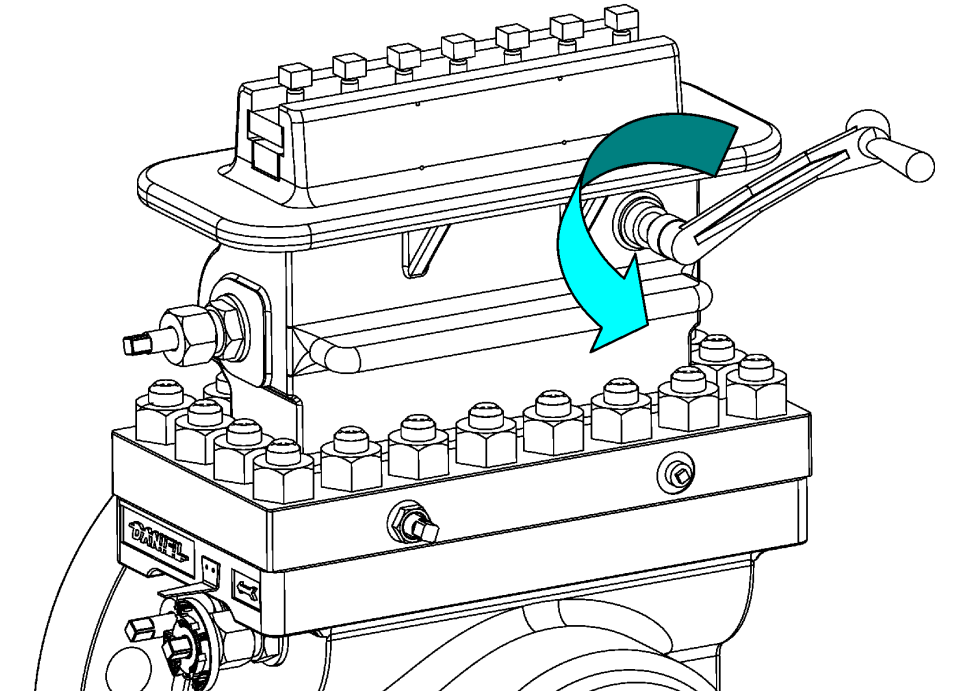

⚠ WARNING

PRESSURIZED FLUID HAZARD

When opening the bleeder valve (10B) or venting the Top (14) through the bleeder valve (10B), direct the released pressurized fluid away from any individual in accordance with local environment regulations to a safe area.

The bleeder valve (10B) releases pressurized fluid that may cause contamination and/or accumulation of volatile gas mixtures. Failure to comply may cause death or serious injury.

The bleeder valve (10B) releases pressurized fluid that may cause contamination and/or accumulation of volatile gas mixtures. The bleeder valve should remain closed after orifice plate insertion in order to prevent toxic gas from being emitted into the atmosphere. Failure to do so may cause serious injury or death.

Steps 11 and 12 are ONLY required for the Seniors equipped with grease assisted, metal-to-metal slide valves. Personnel operating the Senior equipped with O-Ring seal "soft seat" design slide valves skip to step 12.

11. Remove the stem from the Grease Gun (23) with the Operating Wrench (2) and insert a lubricant stick into the Grease Gun (23).

Figure 4-51: Step 11

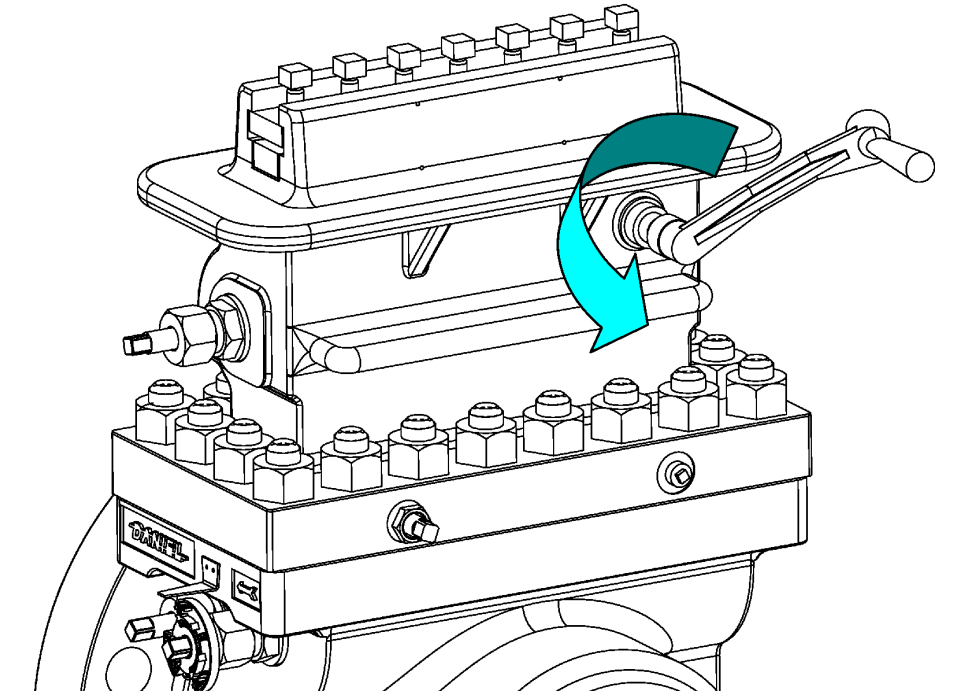
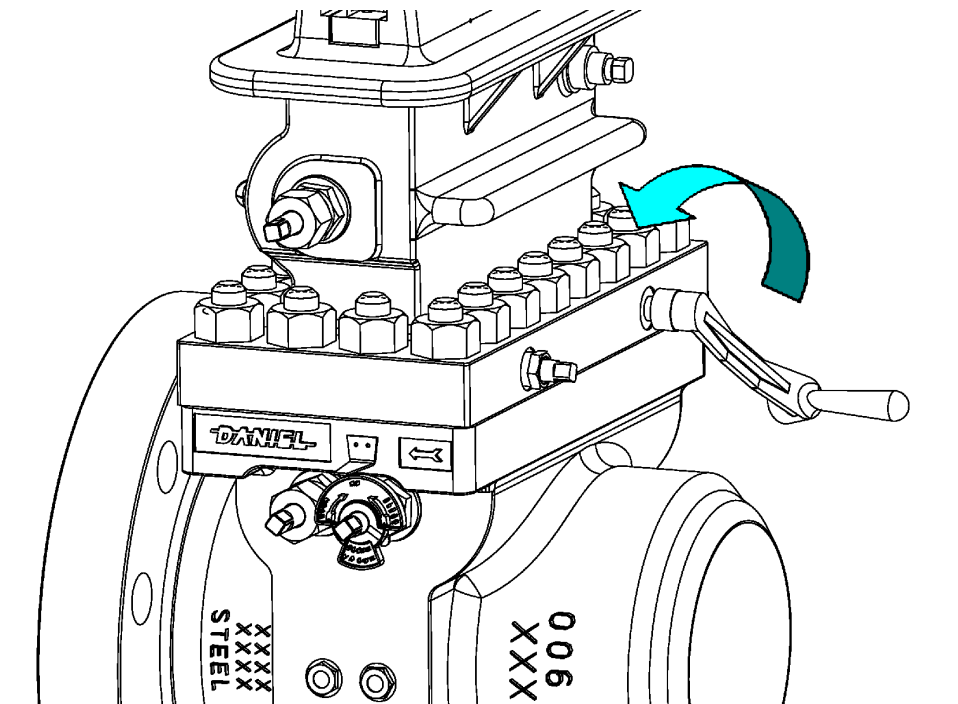

Figure 4-52: Step 11A



 **WARNING**

PRESSURIZED FLUID HAZARD

Using the Grease Gun (23), inject grease into the slide valve seat channels at a rate of 4 to 6 turns per minute and only under the following conditions:

- Bleeder Valve is open.
- Sealing bar/Clamping bar is in place and tight.

Injection of the grease at a faster rate will lead to the separation of the valve strip from the valve seat, resulting in release of pressurized fluid which may cause death or serious injury.

12. Return the stem to the Grease Gun (23) and begin turning it clockwise by hand into the Grease Gun (23) until resistance is felt. Once this is done, use the supplied Operating Wrench (2) to continue to turn the stem clockwise, at a rate of 4 to 6 turns per minute.

Figure 4-53: Step 12

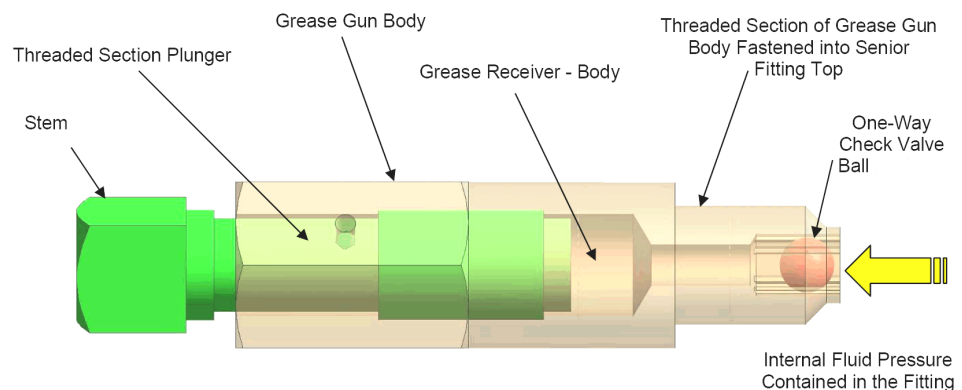

Grease Gun (23)

Important

By turning the stem of the Grease Gun (23) at a rate of 4 to 6 turns per minute, the lubricant is forced through the Slide Valve Seat (18) channels at a rate that allows the lubricant to travel freely, yet not separate the valve strip from the valve seat. This method will keep fresh grease in the lubrication passages.

Although the fluid pressure contained in the Top (14) is reduced to ambient conditions in the following operations, remnants of the fluid still remain in that chamber. The operator must employ a system to address the remaining fluid based upon the fluids' chemical composition and toxicity.

13. Monitor the fluid/gas pressure in the Top (14) until it is equal to ambient conditions.



WARNING

RELEASE OF FLUIDS OR COMPONENTS HAZARD

The Clamping Bar (12 or 12HP) may not be securely in place. Sudden release of fluid or internal components may occur. Never place the Operating Wrench (2) on the Slide Valve Shaft (5), or any body part in front of the top opening in the Top (14).

Failure to comply may cause death or serious injury.

14. Loosen each Clamping Bar Screw (11) located on the Clamping Bar (12 or 12HP) approximately two turns with the Operating Wrench (2).

Figure 4-54: Step 14

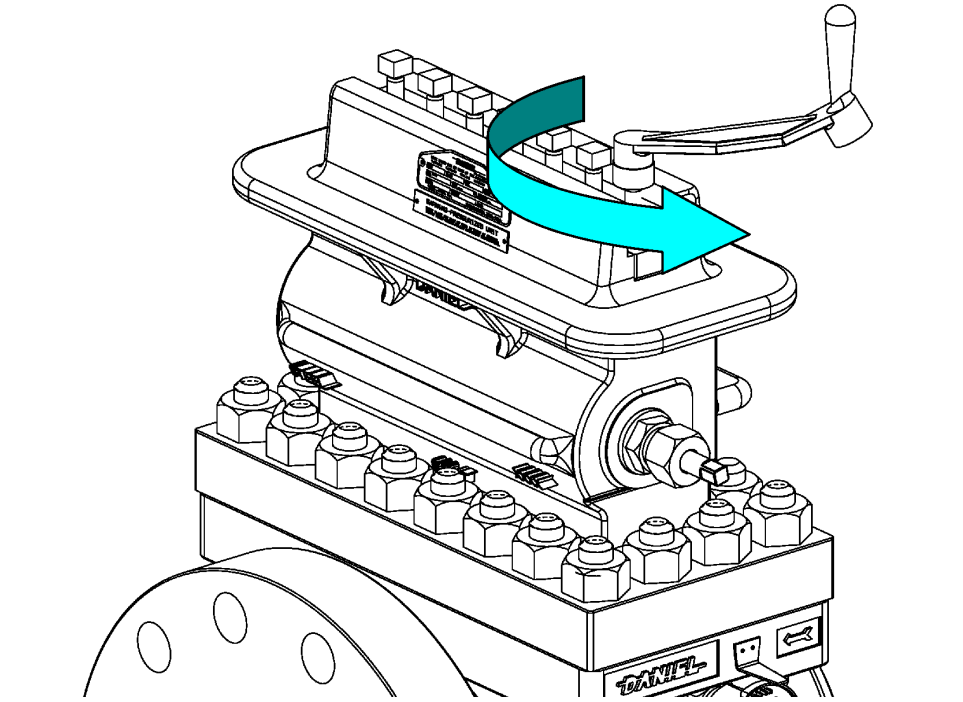

15. Once the Clamping Bar Screws (11) are loose, rotate the Upper Plate Carrier Shaft (7) located in the Top (14) with the Operating Wrench (2), until the Plate Carrier (8DM or 8DMC) taps against the Sealing Bar (9 or 9HP) freeing it from the Top (14).

Figure 4-55: Step 15

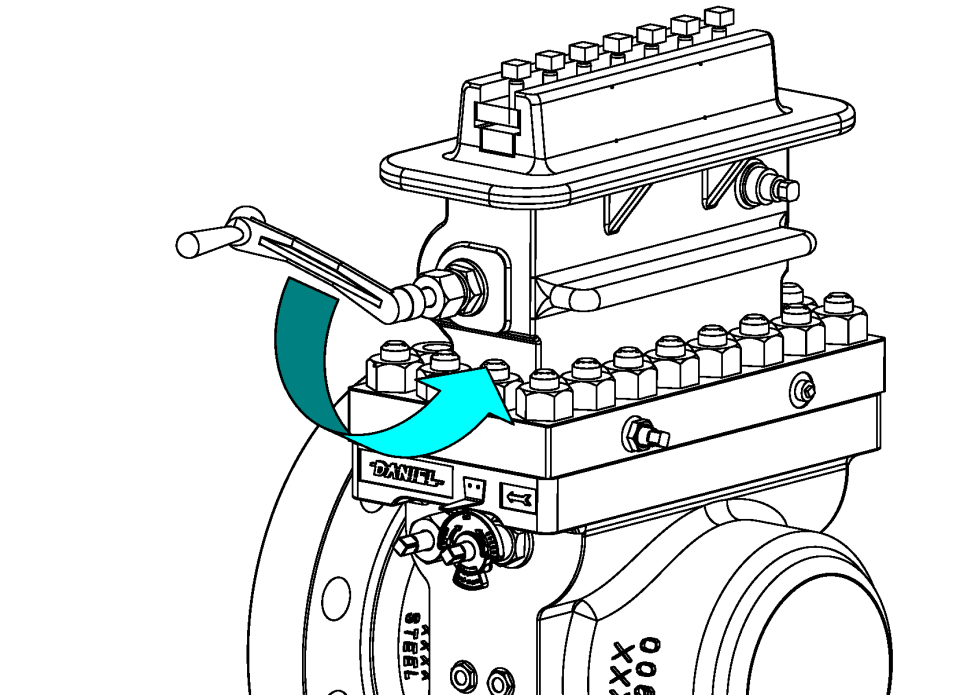

16. Slide the Clamping Bar (12 or 12HP) containing the Clamping Bar Screws (11), the Sealing Bar (9 or 9HP) from the Top (14).

Figure 4-56: Step 16 -17

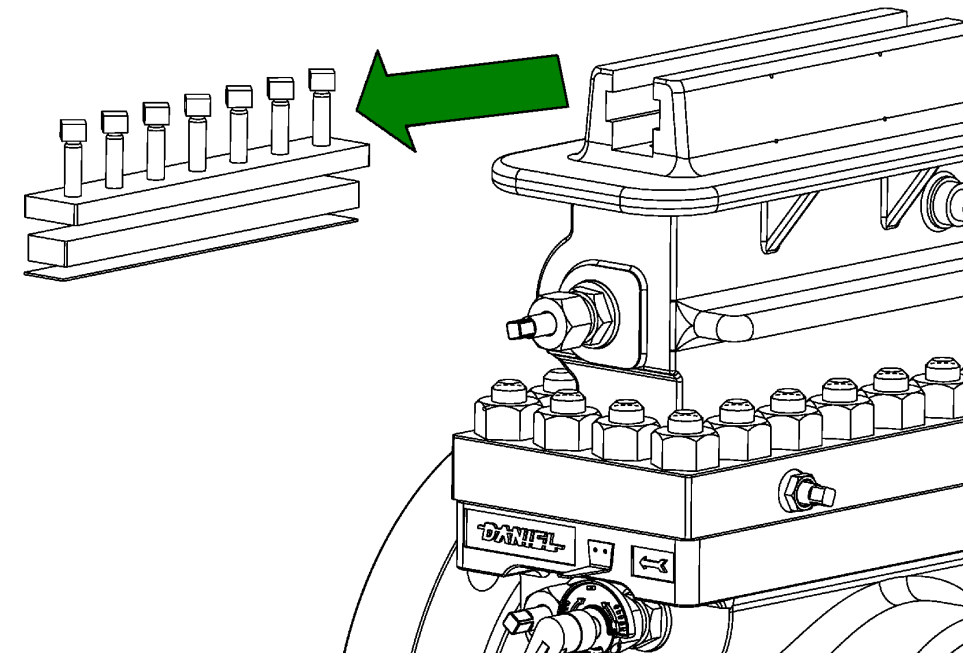

17. Remove the Sealing Bar Gasket (9A, 9A-HP or 9CF) from the Top (14).

18. Rotate the Upper Plate Carrier Shaft (7), located in the Top (14) with the Operating Wrench (2), until the Plate Carrier (8DM or 8DMC) extends outside of the Top (14) and continue to rotate the Upper Plate Carrier Shaft (7) until the Upper Plate Carrier Shaft (7) gears and the Plate Carrier (8DM or 8DMC) gear rack ratchet.

Figure 4-57: Step 18

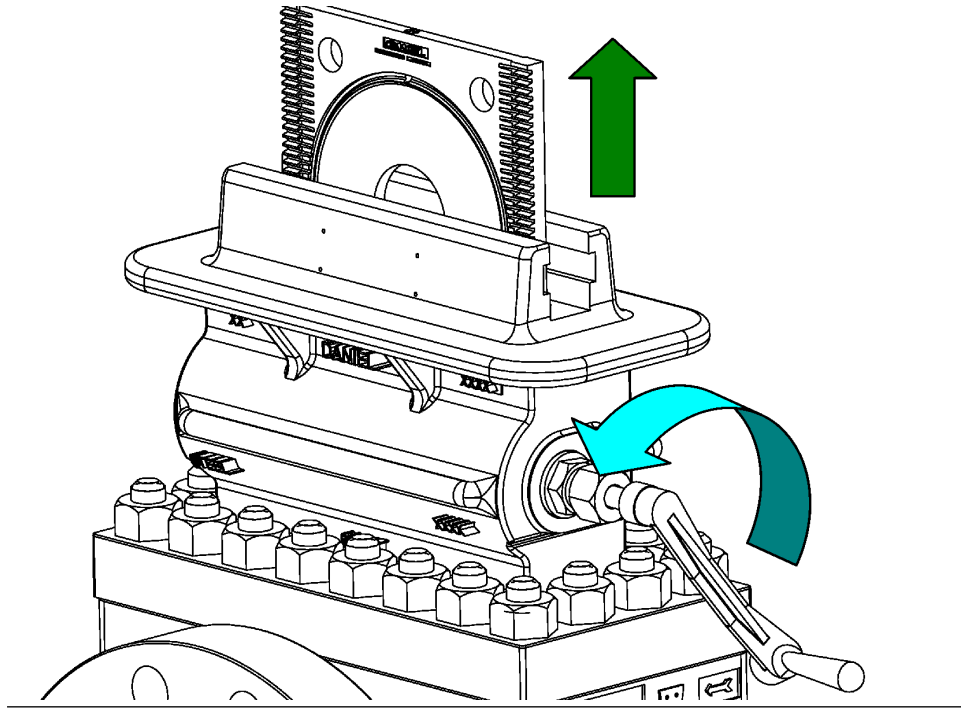

19. Remove the Orifice Plate Carrier (8DM or 8DMC) from the Top (14) and perform the scheduled work on the Orifice Plate (13) and Orifice Plate Carrier (8DM or 8DMC).

20. Close the Bleeder Valve (10B) using the Operating Wrench (2).

Figure 4-58: Step 20

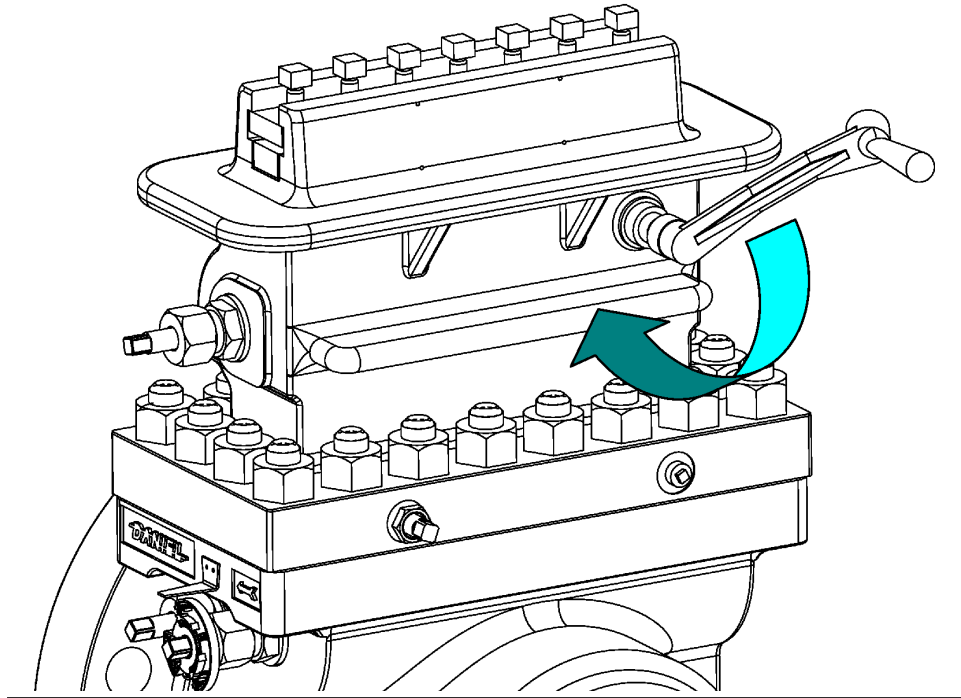

⚠ WARNING

EXPLOSION HAZARD

Ensure that the Sealing Bar Gasket (9A, 9A-HP or 9CF), the Sealing Bar (9 or 9HP) and the Clamping Bar (12 or 12HP) provide a pressure barrier between the line pressure and the atmosphere.

Failure to properly install these parts may result in explosive separation of components resulting in death or serious injury.

Failure to properly install these parts may result in explosive separation of components resulting in serious injury or death.

21. Immediately install a new Sealing Bar Gasket (9A, 9A-HP or 9CF) on the Top (14) along with the Sealing Bar (9 or 9HP) and the Clamping Bar (12 or 12HP).

Figure 4-59: Step 21

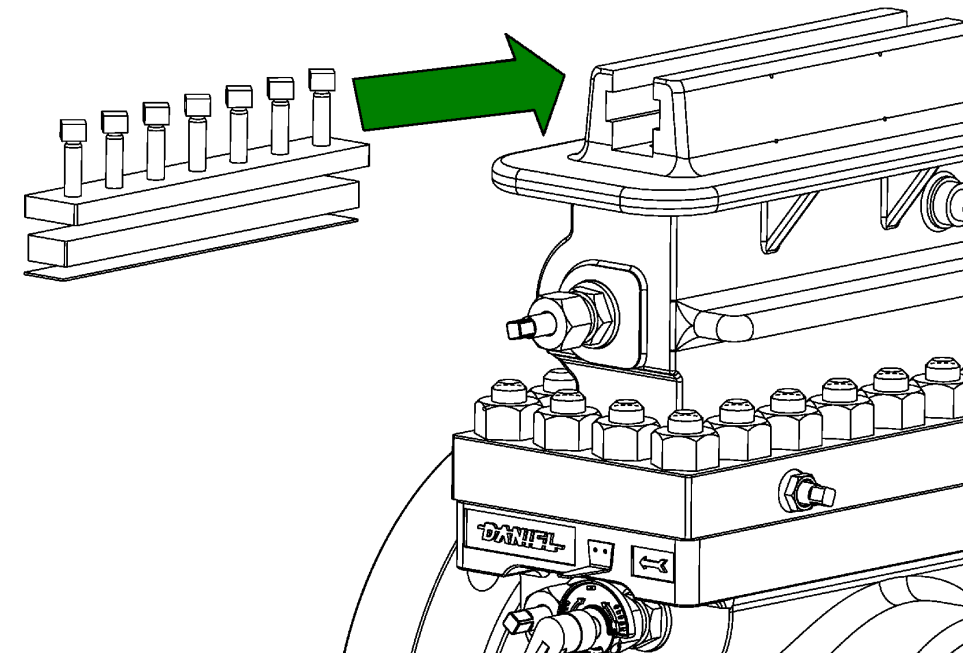

22. Tighten each Clamping Bar Screw (11) located on the Clamping Bar (12 or 12HP)
(Reference: [Torque information.](#))

Figure 4-60: Step 22

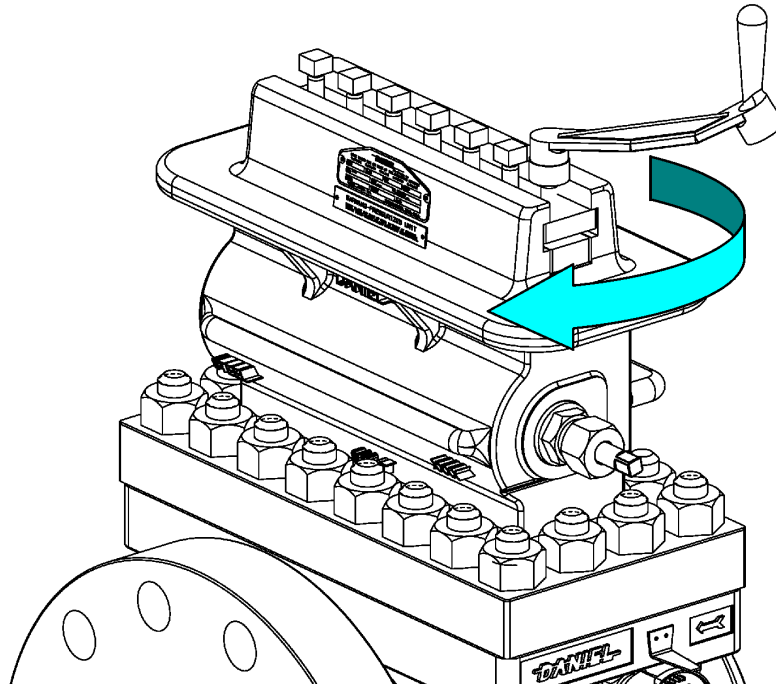

Important

At this stage in the operational procedure, the Senior is at the following conditions:

- The Equalizer Valve (1) is closed.
- The Bleeder Valve (10B) closed.
- The Slide Valve is closed.
- The Sealing Bar (9 or 9HP), the Clamping Bar (12 or 12HP), and a new Sealing Bar Gasket (9A, 9A-HP or 9CF) are installed on the Top (14).

Therefore, the operator may now perform the scheduled work on the Orifice Plate (13) and the Orifice Plate Carrier (8DM or 8DMC) without time restriction.

23. Complete work on the Orifice Plate Carrier (8DM or 8DMC) and prepare the Senior for insertion of the Orifice Plate Carrier (8DM or 8DMC).

24. Open the Bleeder Valve (10B) with the Operating Wrench (2)

Figure 4-61: Step 24

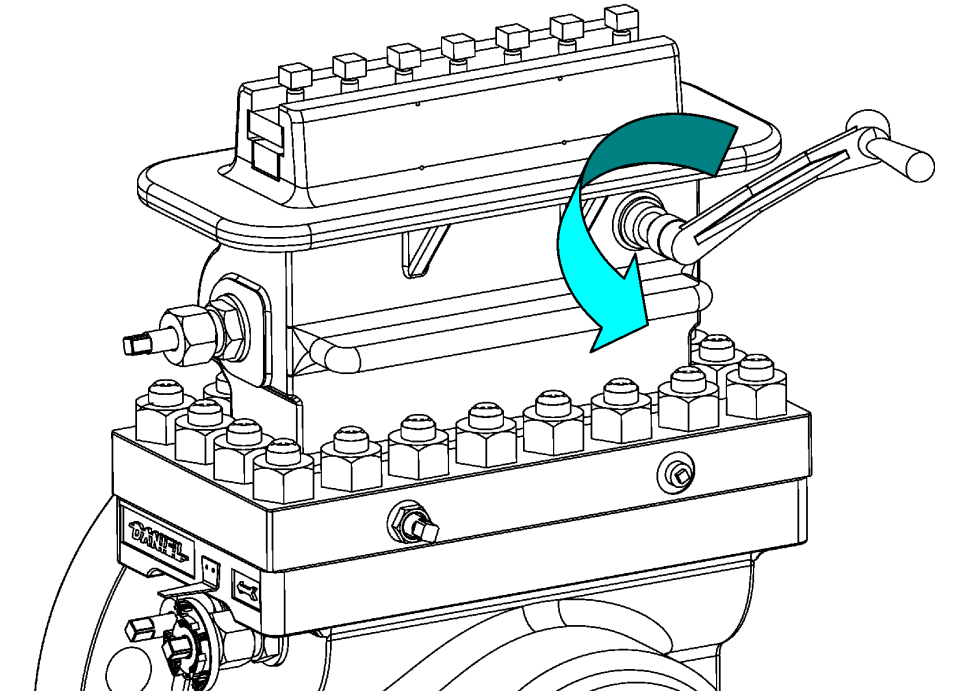

Steps 25 and 26 are ONLY required for the Seniors equipped with grease assisted, metal-to- metal slide valves. Personnel operating Seniors equipped with O-Ring seal "soft seat" design slide valves skip to step 27.

25. Remove the stem from the Grease Gun (23) with the Operating Wrench (2) and insert a lubricant stick into the Grease Gun (23).

Figure 4-62: Step 25

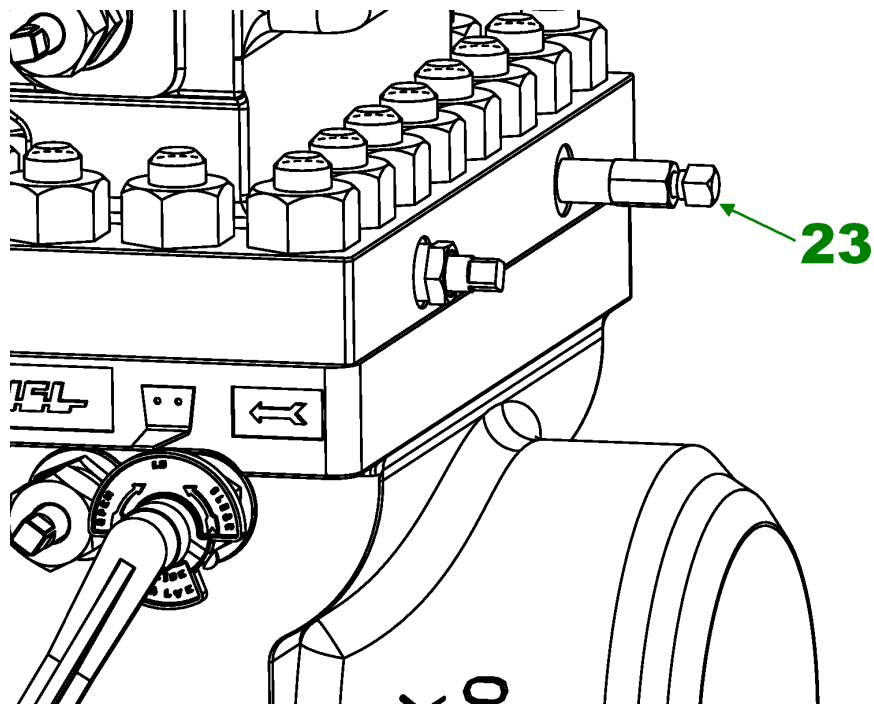
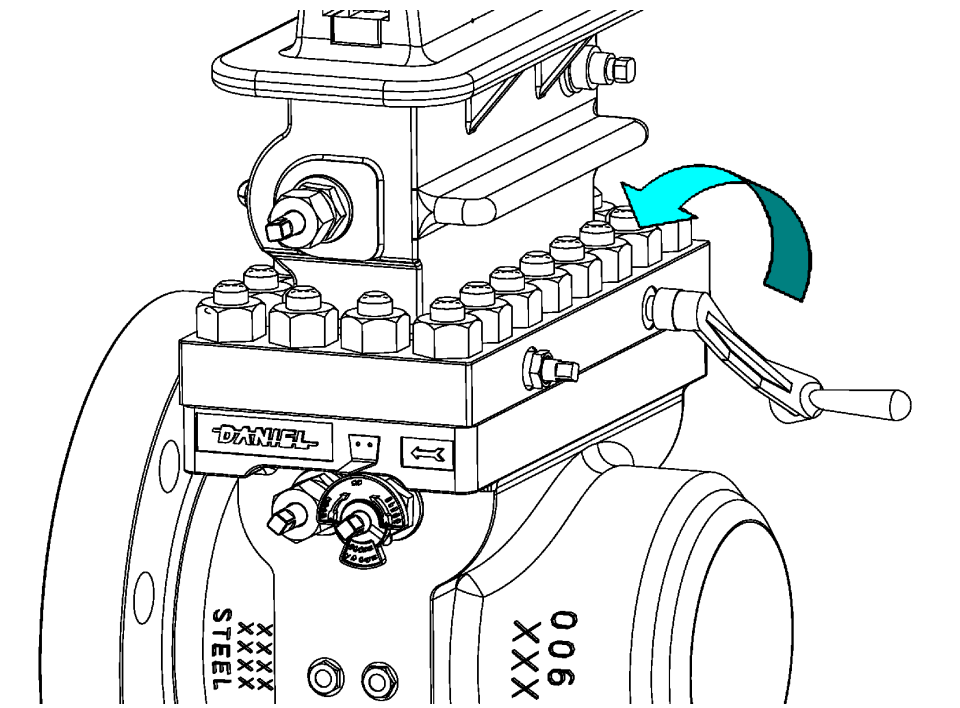

Figure 4-63: Step 25A



26. Return the stem to the Grease Gun (23) and begin turning it clockwise by hand into the Grease Gun (23) until resistance is felt. Once this is done, use the supplied Operating Wrench (2) to continue to turn the stem at a rate of 4 to 6 turns per minute.

! WARNING

PRESSURIZED FLUID HAZARD

Using the Grease Gun (23), inject grease into the slide valve seat channels at a rate of 4 to 6 turns per minute and only under the following conditions:

- Bleeder Valve is open.
- Sealing bar/Clamping bar is in place and tight.

Injection of the grease at a faster rate will lead to the separation of the valve strip from the valve seat, resulting in release of pressurized fluid which may cause death or serious injury.

Figure 4-64: Step 26

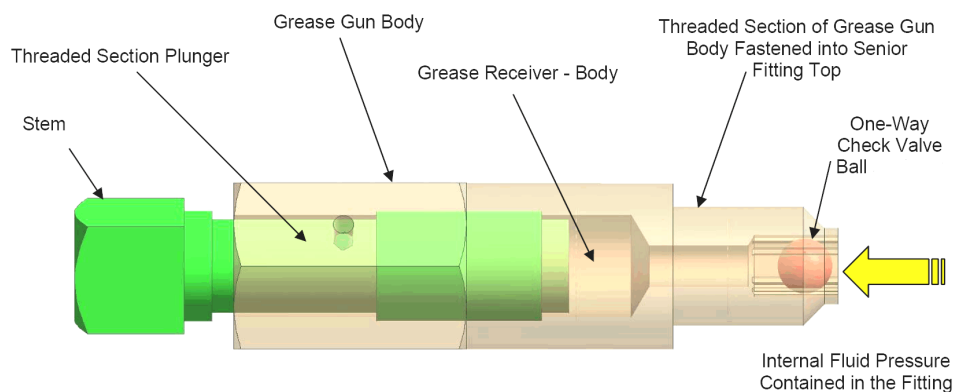

Grease Gun (23)

Important

By turning the stem of the Grease Gun (23) at a rate of 4 to 6 turns per minute, the lubricant is forced through the Slide Valve Seat (18) channels at a rate that allows the lubricant to travel freely, yet not separate the valve strip from the valve seat. This method will keep fresh grease in the lubrication passages.

! WARNING

PRESSURIZED FLUID HAZARD

When opening the bleeder valve (10B) or venting the Top (14) through the bleeder valve (10B), direct the released pressurized fluid away from any individual in accordance with local environment regulations to a safe area.

The bleeder valve (10B) releases pressurized fluid that may cause contamination and/or accumulation of volatile gas mixtures. Failure to comply may cause death or serious injury.

NOTICE

The pressure contained in the Top (14) must be lowered to ambient pressure in order to begin any Orifice Plate (13) procedures. When lowering the pressure in the Top (14), the operator must direct fluid or gas escaping from the Top (14) to a safe area away from the operator, and in accordance with local environmental regulations.

Although the fluid pressure contained in the Top (14) is reduced to ambient conditions in the following operations, remnants of the fluid still remain in that chamber. The operator must employ a system to address the remaining fluid based upon the fluids' chemical composition and toxicity.

27. Monitor the fluid/gas pressure in the Top (14) to ensure that it is equal to ambient conditions.

28. Loosen each Clamping Bar Screw (11) located on the Clamping Bar (12 or 12HP) approximately two turns with the Operating Wrench (2).

Figure 4-65: Step 28

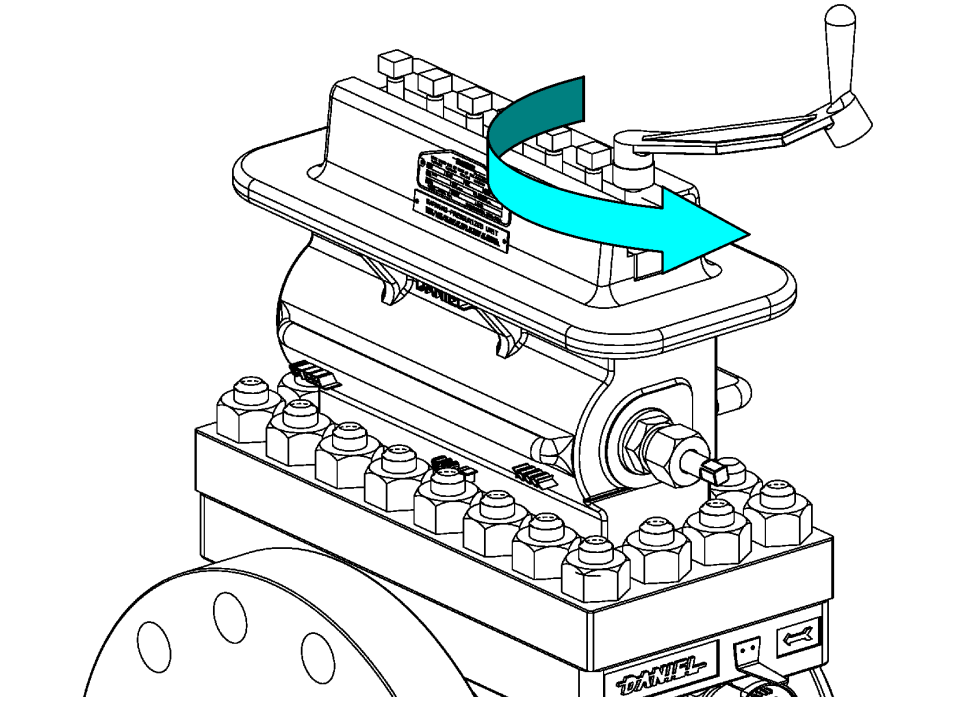

29. Once the Clamping Bar Screws (11) are loose, it may be necessary to use the Operating Wrench (2) to tap against the Sealing Bar (9 or 9HP) freeing it from the Top (14).

Figure 4-66: Step 29

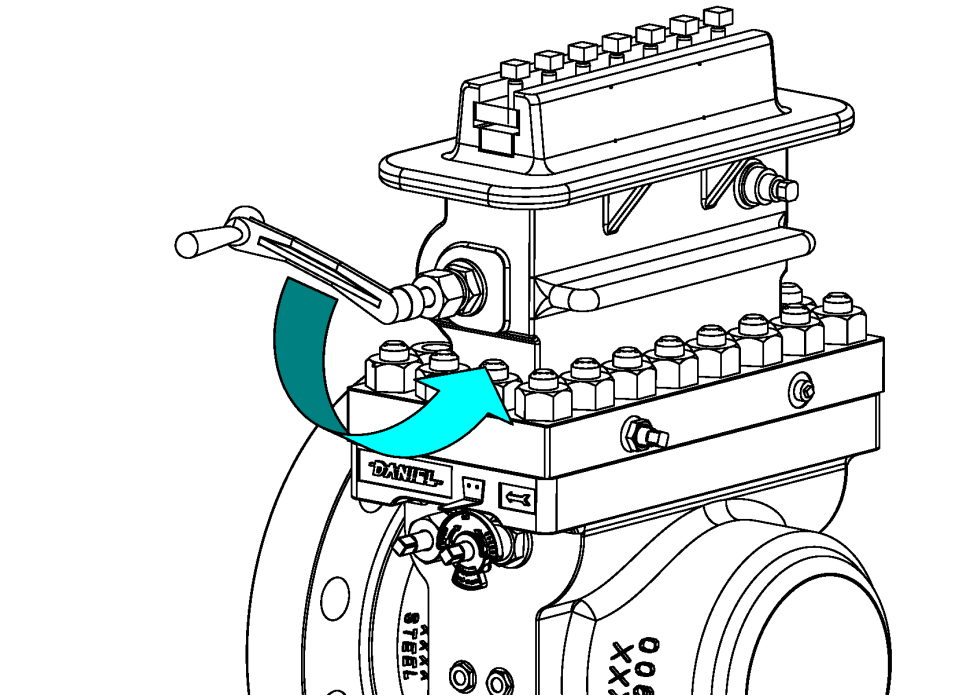

30. Slide the Clamping Bar (12 or 12HP) containing the Clamping Bar Screws (11), the Sealing Bar (9) from the Top (14).

Figure 4-67: Step 30 - 31

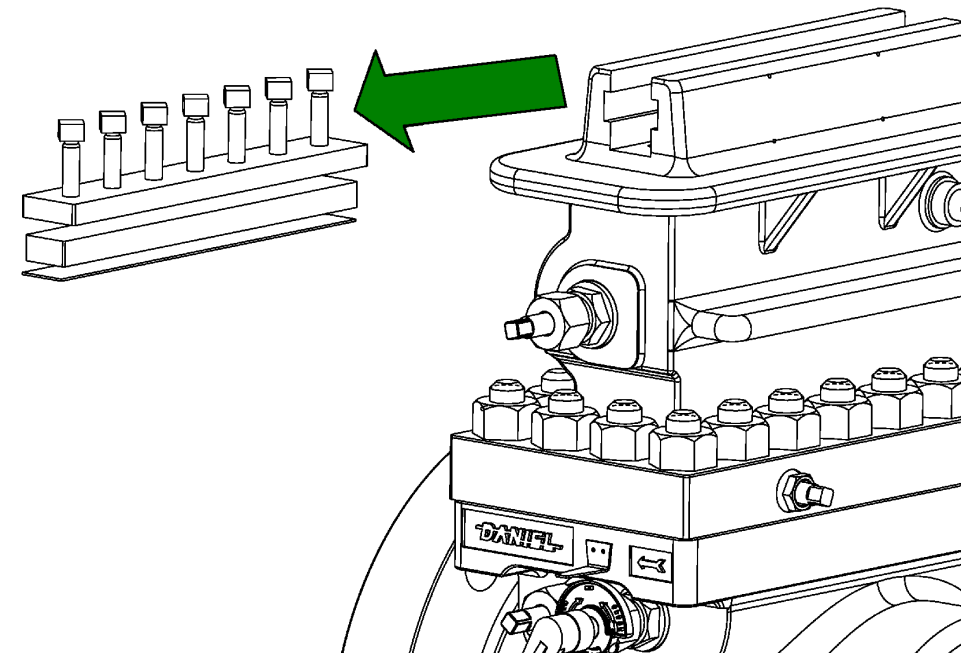

31. Remove the Sealing Bar Gasket (9A, 9A-HP or 9CF) from the Top (14).
32. Insert the Orifice Plate Carrier (8DM or 8DMC) into the Top (14) until the Upper Plate Carrier Shaft (7) gears and plate carrier gear rack mesh.
33. With the Operating Wrench (2), rotate the Upper Plate Carrier Shaft (7), located in the Top (14), a minimum of one quarter turns OPPOSITE of the direction required to lower the Orifice Plate Carrier (8DM or 8DMC) into the Top (14). This action allows the Orifice Plate Carrier (8DM or 8DMC) to properly "align" the Orifice Plate Carrier (8DM or 8DMC) with the plate carrier shaft.

! WARNING

PRESSURIZED FLUID HAZARD

Do not lower the Plate Carrier (8DM or 8DMC) directly onto the slide valve as it may damage the sealing features and release pressurized fluid.

Damaging the sealing features may cause contamination and/or accumulation of volatile gas mixtures, resulting in death or serious injury and equipment damage.

34. Once the Orifice Plate Carrier (8DM or 8DMC) is aligned, rotate the Upper Plate Carrier Shaft (7) with the Operating Wrench (2), in a direction to lower the Orifice Plate Carrier (8DM or 8DMC) into the Top (14) until all of the Orifice Plate Carrier (8DM or 8DMC) is below the Sealing Bar Gasket (9A, 9A-HP or 9CF) surface.

Figure 4-68: Step 34

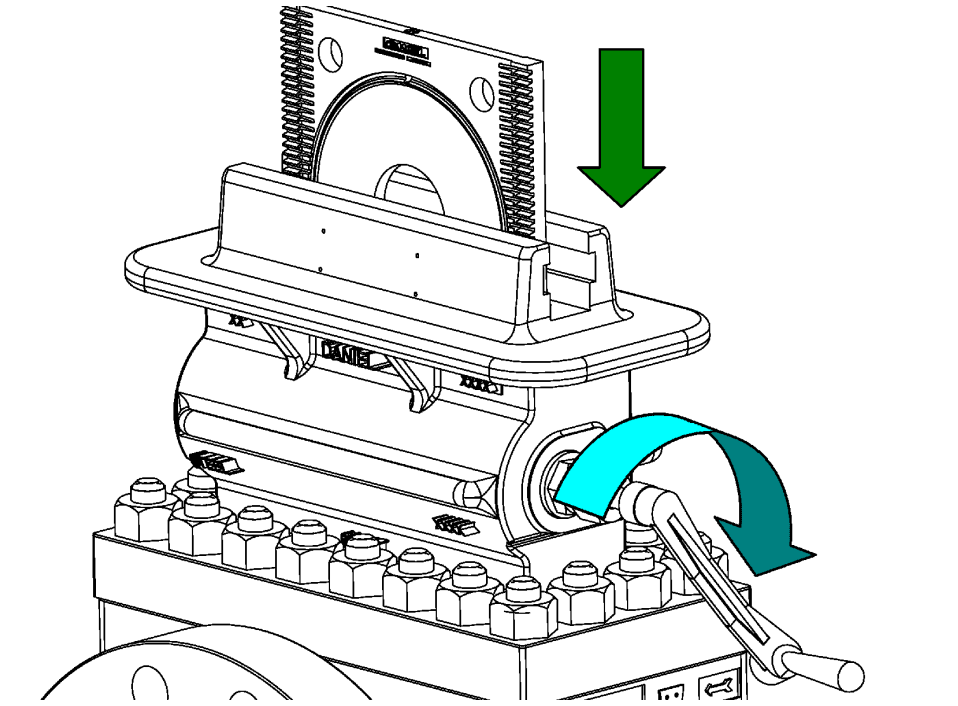

⚠ WARNING

EXPLOSION HAZARD

Ensure that the Sealing Bar Gasket (9A, 9A-HP or 9CF), the Sealing Bar (9 or 9HP) and the Clamping Bar (12 or 12HP) provide a pressure barrier between the line pressure and the atmosphere.

Failure to properly install these parts may result in explosive separation of components resulting in death or serious injury.

35. Install a new Sealing Bar Gasket (9A, 9A-HP or 9CF) on to the Top (14).

Figure 4-69: Step 35 - 36

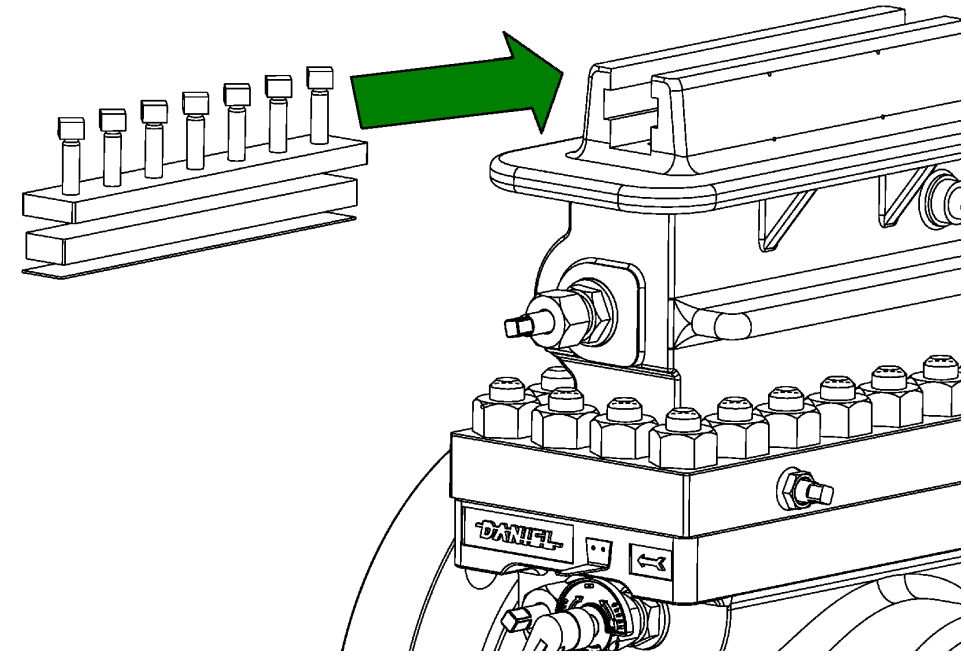

36. Install the Sealing Bar (9 or 9HP) and the Clamping Bar (12 or 12HP) on to the Top (14).

37. Tighten each Clamping Bar Screw (11), located on the Clamping Bar (12 or 12HP) (Reference: [Torque information.](#))

Figure 4-70: Step 37

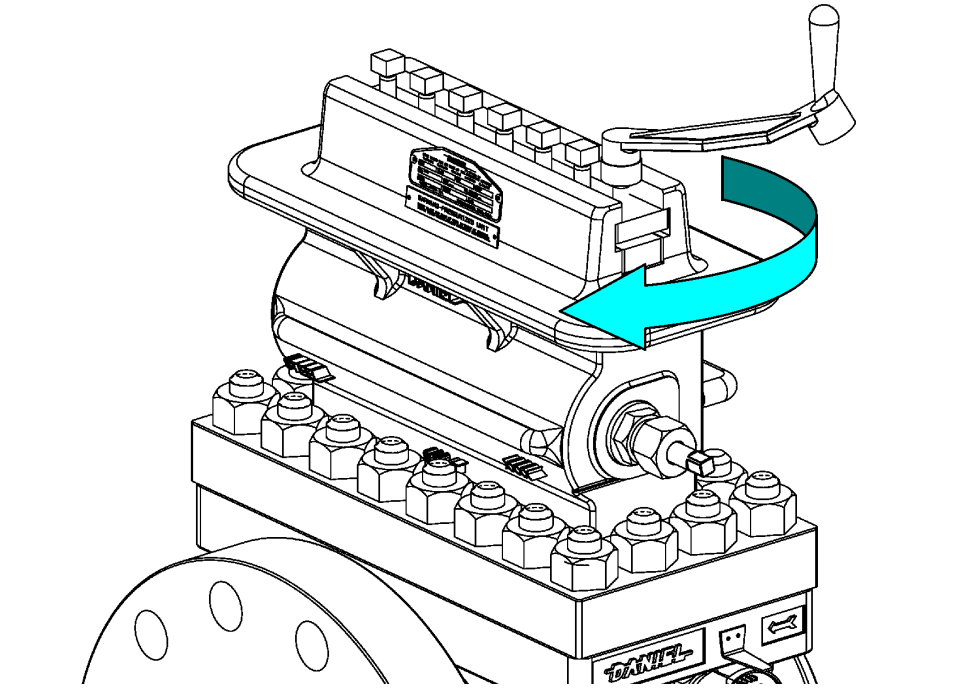

38. Close the Bleeder Valve (10B).

Figure 4-71: Step 38

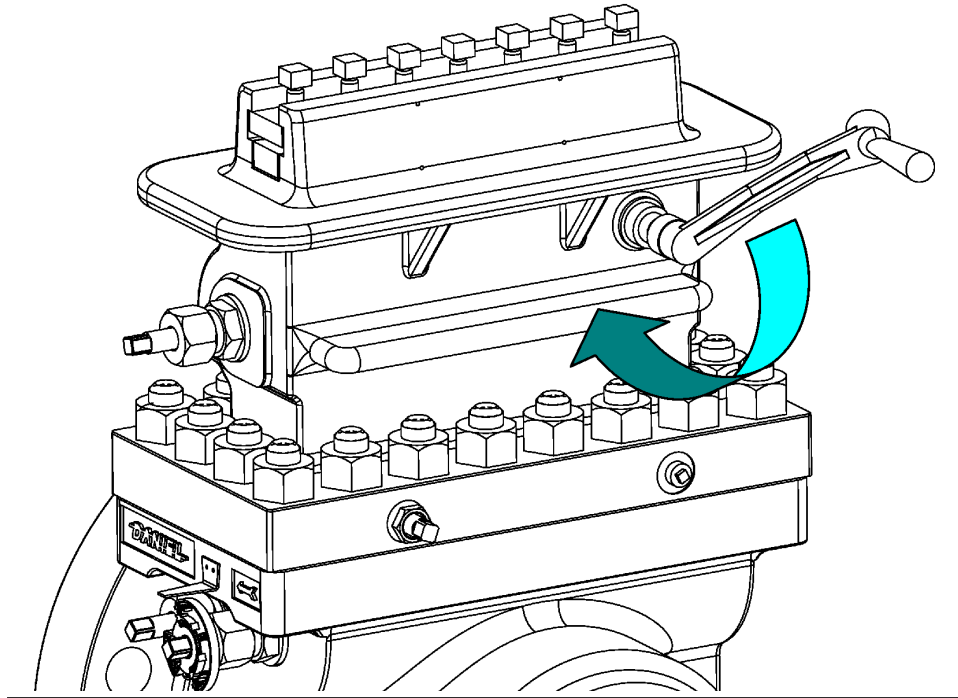

39. Open the Equalizer Valve (1) one-half to two turns with the Operating Wrench (2).

Figure 4-72: Step 39

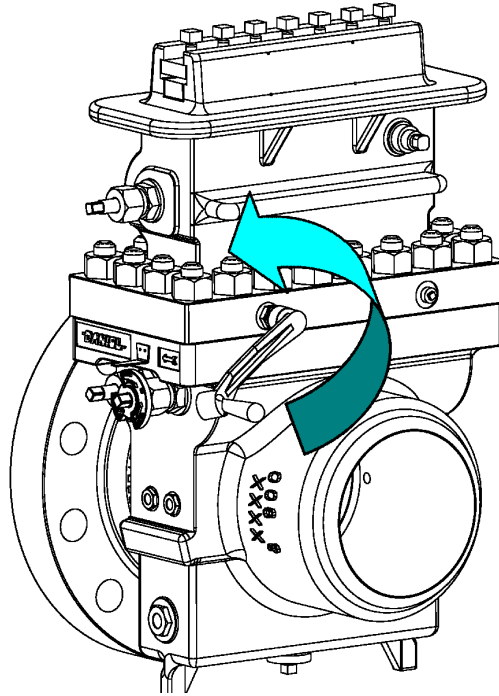

40. Wait several seconds for the Top (14) to reach pressure equilibrium with the line pressure contained in the Body (4).

Figure 4-73: Step 40

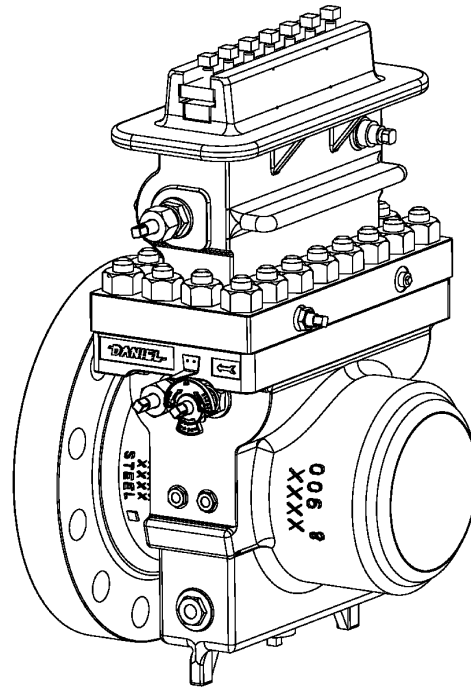

41. Using the Operating Wrench (2), rotate the Slide Valve Shaft (5) to the OPEN position.

Figure 4-74: Step 41

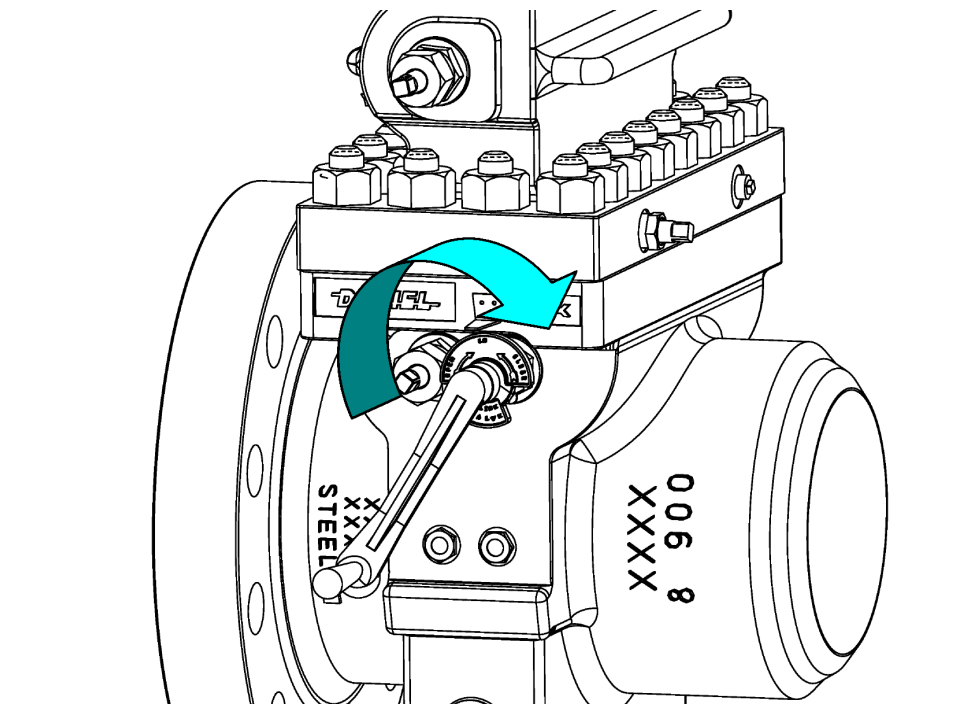

42. Rotate the Upper Plate Carrier Shaft (7) located in the Top (14) with the Operating Wrench (2) in the direction to lower the Orifice Plate Carrier (8DM or 8DMC) into the Body (4).

Figure 4-75: Step 42

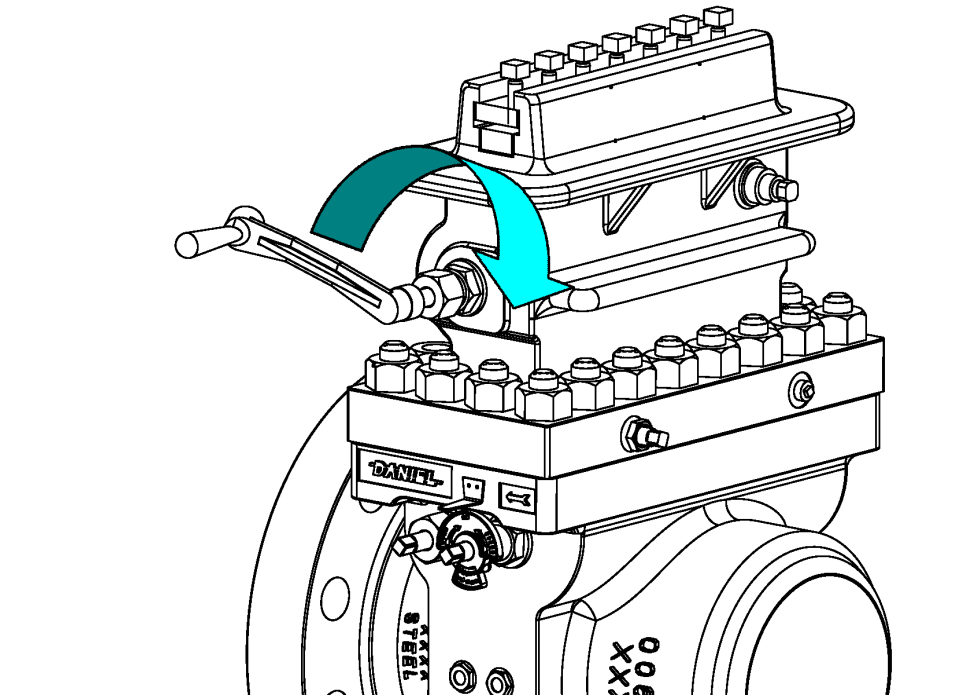

43. Rotate the Lower Plate Carrier Shaft (6) with the Operating Wrench (2) until the Orifice Plate Carrier (8DM or 8DMC) cannot be lowered further.

Figure 4-76: Step 43

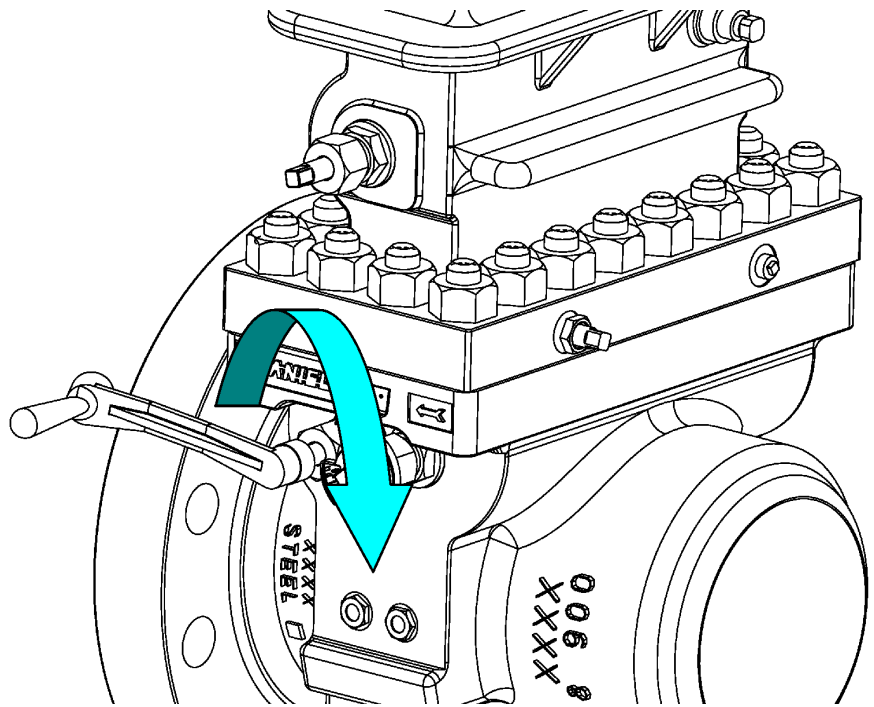

Important

Resistance to turning will be present when the Orifice Plate Carrier (8DM or 8DMC) is approaching its proper measurement position due to friction between the Senior Body (4) and the Orifice plate seal (8E-DSC, etc.).

44. Once the Orifice Plate Carrier (8DM or 8DMC) is positioned in the Body (4), turn the Slide Valve Shaft (5) using the Operating Wrench (2) into the CLOSED position.

Figure 4-77: Step 44

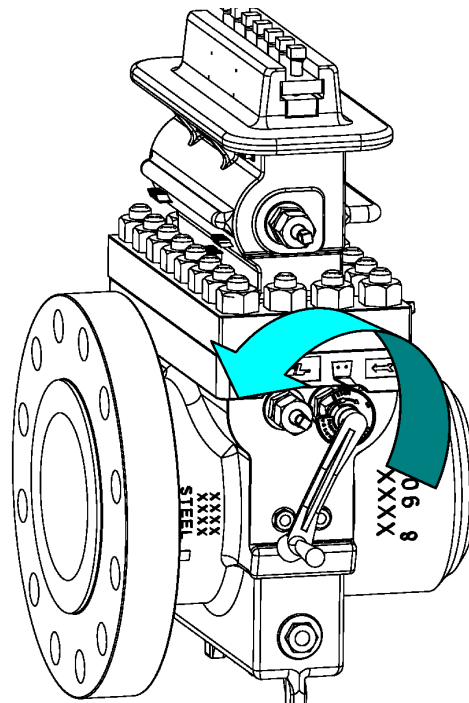

45. Close the Equalizer Valve (1).

Figure 4-78: Step 45

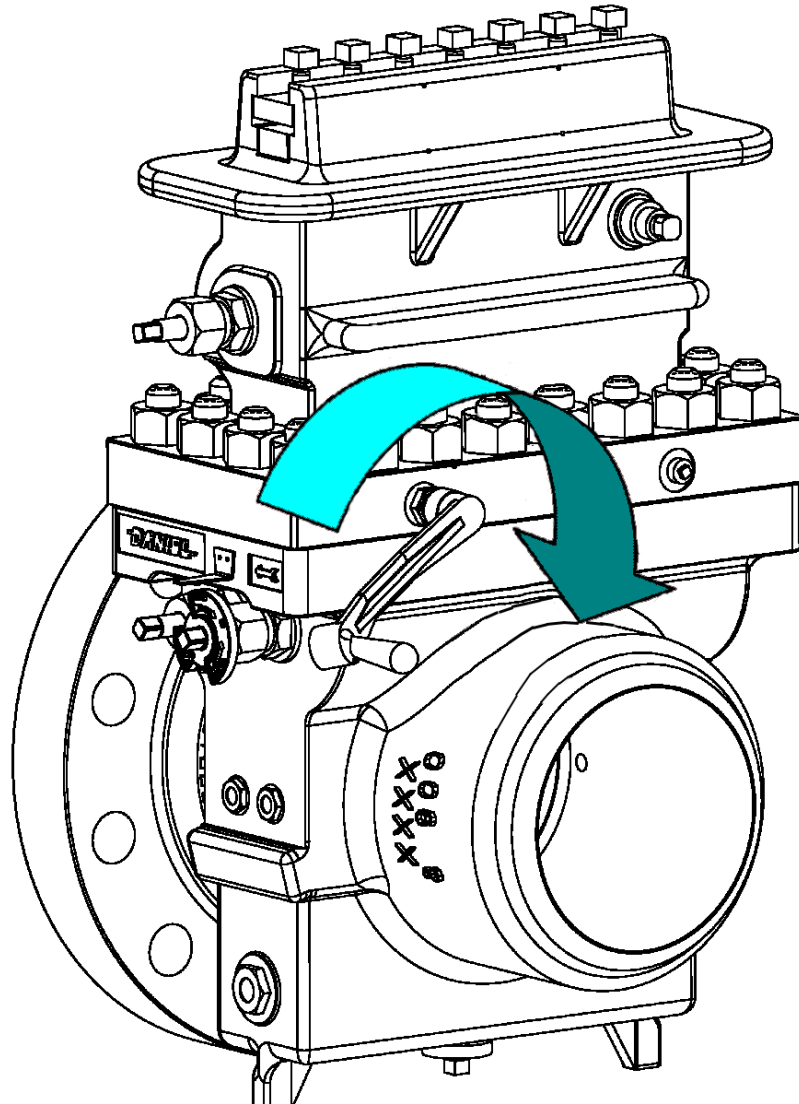

! WARNING

PRESSURIZED FLUID HAZARD

When opening the bleeder valve (10B) or venting the Top (14) through the bleeder valve (10B), direct the released pressurized fluid away from any individual in accordance with local environment regulations to a safe area.

The bleeder valve (10B) releases pressurized fluid that may cause contamination and/or accumulation of volatile gas mixtures. Failure to comply may cause death or serious injury.

46. Open the Bleeder Valve (10B) to vent the Top (14).

Figure 4-79: Step 46

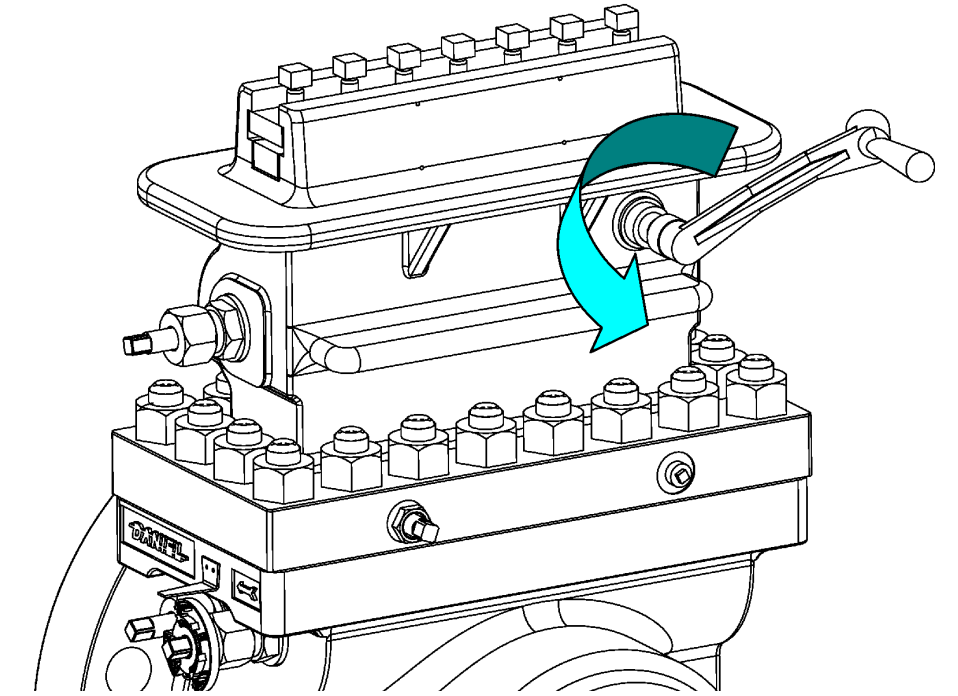

Step 47 and 48 are ONLY required for Seniors equipped with grease assisted, metal-to-metal slide valves. Personnel operating the Daniel Senior Orifice Fitting equipped with O-Ring seal "soft seat" design slide valves skip to step 49.

47. Remove the stem from the Grease Gun (23) with the Operating Wrench (2) and insert a lubricant stick into the Grease Gun (23).

Figure 4-80: Step 47

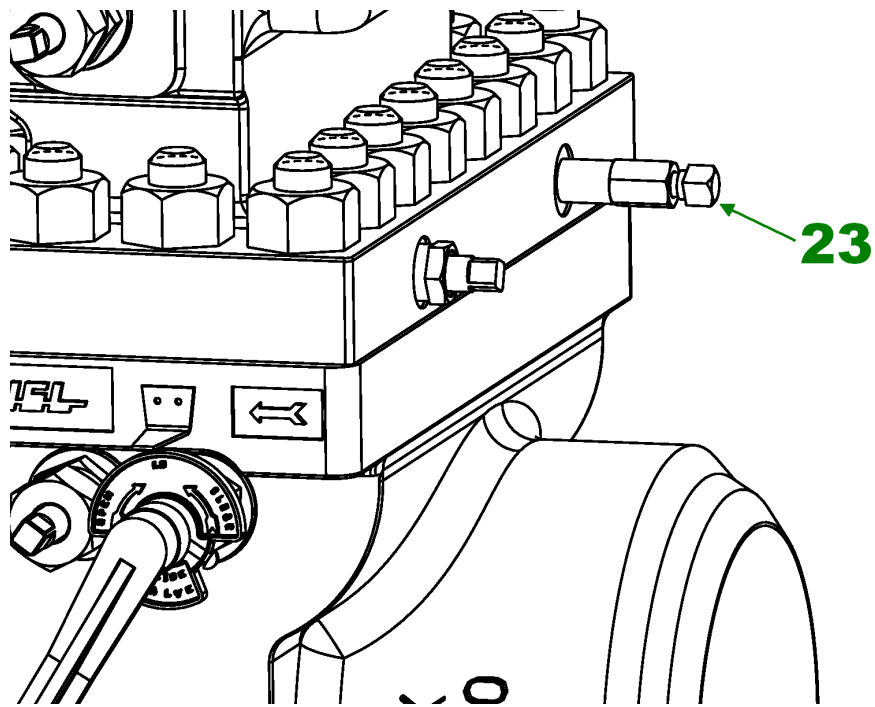
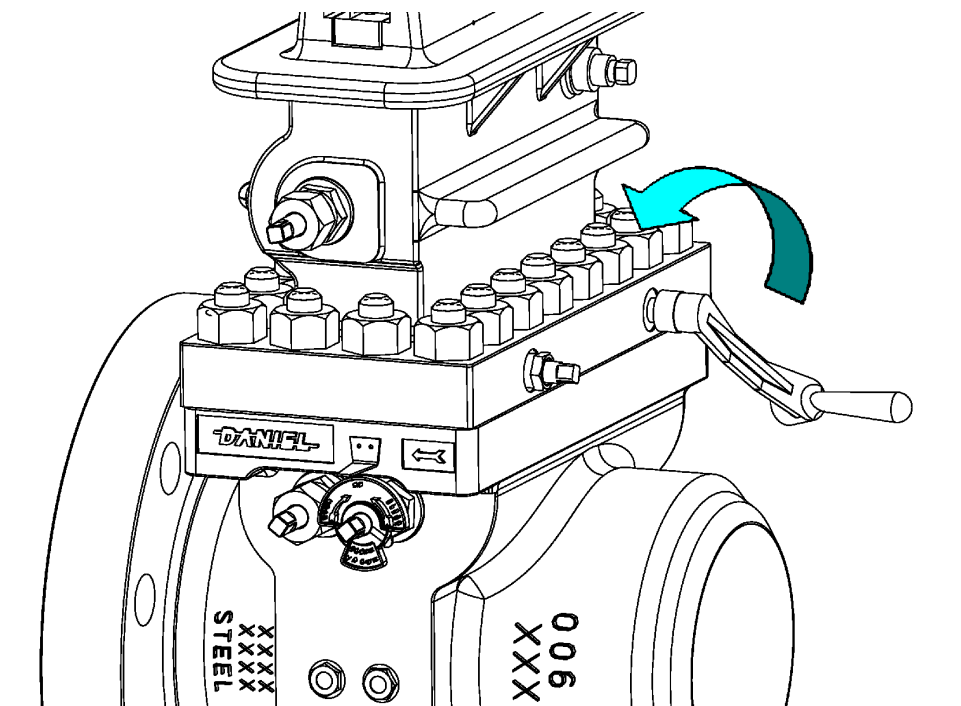

Figure 4-81: Step 47A



 **WARNING**

PRESSURIZED FLUID HAZARD

Using the Grease Gun (23), inject grease into the slide valve seat channels at a rate of 4 to 6 turns per minute and only under the following conditions:

- Bleeder Valve is open.
- Sealing bar/Clamping bar is in place and tight.

Injection of the grease at a faster rate will lead to the separation of the valve strip from the valve seat, resulting in release of pressurized fluid which may cause death or serious injury.

48. Return the stem to the Grease Gun (23) and begin turning it clockwise by hand into the Grease Gun (23) until resistance is felt. Once this is done, use the supplied Operating Wrench (2) to continue to turn the stem at a rate of 4 to 6 turns per minute.

Figure 4-82: Step 48

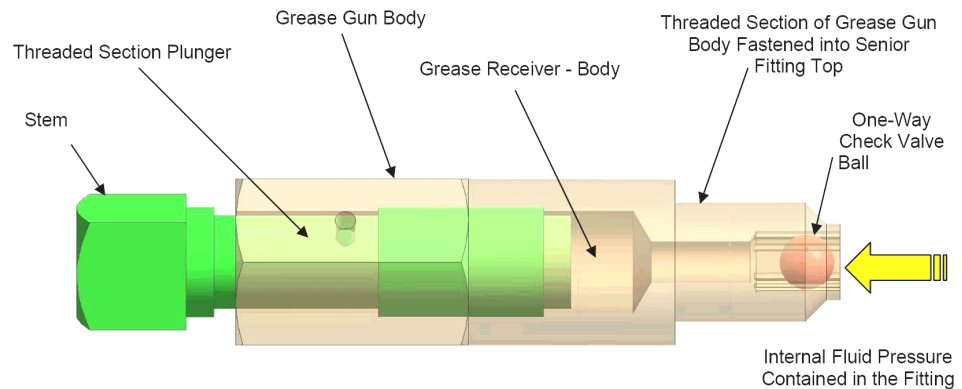

Grease Gun (23)

Important

By turning the stem of the Grease Gun (23) at a rate of 4 to 6 turns per minute, the lubricant is forced through the Slide Valve Seat (18) channels at a rate that allows the lubricant to travel freely, yet not separate the valve strip from the valve seat. This method will keep fresh grease in the lubrication passages.

If the addition of grease does not reduce the flow from the open Bleeder Valve (10B) to zero, follow these steps:

- Close the Bleeder Valve (10B),
- Open the Equalizer Valve (1), and move the Slide Valve Shaft (5) from the CLOSED to the OPEN position, and back to the CLOSED position, repeating this action several times.
- Return the Slide Valve Shaft (5) back to the CLOSED position.
- Close the Equalizer Valve (1) and repeat the lubrication process.
- If leakage is still present, close the Bleeder Valve (10B) and leave the Slide Valve Shaft (5) in the CLOSED position and schedule maintenance on the Senior.
- Open the Bleeder Valve (10B).

49. Close the Bleeder Valve (10B).

Figure 4-83: Step 49

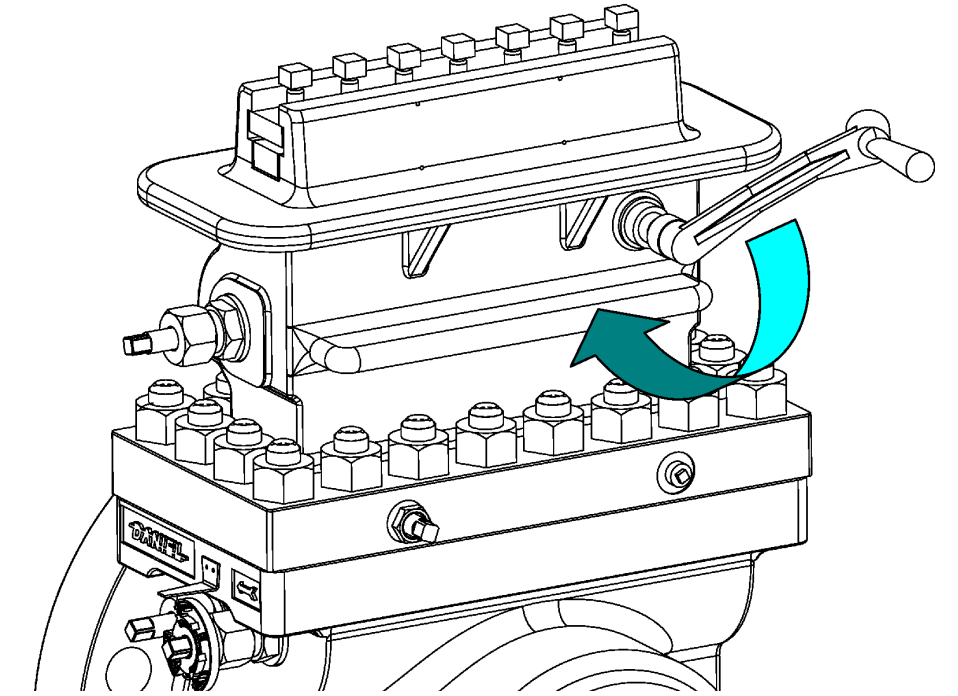

The Daniel Senior Orifice Fitting is now ready for measurement.

5 Supplemental information

5.1 Recommended spare parts for a one-year operation

Table 5-1: Recommended spare parts

Item number	ANSI	Description	Material	Quantity
5	150-2500	Shaft	CS (ZP)	1
8E-DSC/8E-DS	150-600	Orifice plate sealing unit (DSC/2"-8"; DS/10")	NBR	5
8TSC/8TS	900-2500	Orifice plate sealing unit (TSC/2"-8"; TS/10"-16")	TFE/PTFE	3
9A	150-900	Sealing bar gasket	Aramid Fiber/NBR binder non-Asbestos Flat Sheet	5
9CF	1500-2500	Sealing bar gasket	Rubber O-ring	3
11	150-2500	Clamping bar screws	Alloy steel (ZP)	2
18A	150-900	Slide valve seat	Composition	1
18A	1500	Slide valve seat/top gasket	Composition	1
14CF	1500	Body/top gasket (O-ring)	Special compound	1
14CF-A	2500	Body/top gasket (Metal backed O-ring)	CS (ZP)/ NBR	1
22A	150-1500	Stuffing box/bearing plug gasket	316 SS	2
22A	2500	Stuffing box/bearing plug gasket	316 SS	2
22B	2500	Stuffing box/bearing plug o-ring	NBR O-ring	2
25A	150-1500	Packing rings	TFE/PTFE	1-set
25A-HP	2500	Packing rings	TFE/PTFE	1-set
25B	150-1500	Centering rings	TFE/PTFE	1-set
25B-HP	2500	Centering rings	TFE/PTFE	1-set
26C	2500	External gland outer o-ring	NBR O-ring	1
26D	2500	External gland inner o-ring	NBR O-ring	1
26D	2500	Internal gland o-ring	NBR O-ring	1
	150-2500	Slide valve lubricant		3 boxes

Materials listed above are for standard "A" trim assemblies. For other trim options, consult with a Flow Lifecycle Services representative for Daniel products for materials of components which are different.

Important

See ordering information in [When ordering parts, please specify Catalog number, size and serial number can be found on the fitting nameplate. Part item numbers and part materials for "NACE" trim only are found in Daniel Senior Orifice Fitting sizes 2"- 8" 150-900..](#)

5.2 Lubricant information

Product owners and operating personnel select the Daniel Senior Orifice Fitting for use in a wide variety of flow measurement services around the world. Information and experience gathered indicate that measurement service conditions do have a profound effect on the metal-to-metal slide valve sealing performance.

Each application presents its own unique set of service and environmental conditions. Therefore, Emerson offers four lubricant greases for use on the grease assisted, metal-to-metal Senior slide valve. These lubricants are:

Table 5-2: Daniel Senior Valve grease assisted metal-to-metal lubricants

Lubricant types	
Type 1 -	Standard: Daniel part Number: 1- 213-04-001
Type 2 -	Sour Gas: Daniel part Number: 1- 213-04-102
Type 3 -	Carbon Dioxide: Daniel part Number: 1- 213-04-101
Type 4 -	High Temperature: Daniel part Number: 1- 213-04-103

The data contained in the following charts below are the result of sealing tests using a 3" ANSI 600 Senior Orifice Fitting. Emerson performed these tests under various laboratory conditions using nitrogen gas as the fluid. All sealing parts and grease were new. Test technicians also cleaned the grease delivery system prior to every test. Each chart represents one of the Emerson greases listed above.

Every filled grid indicates optimum seal performance at a corresponding temperature and pressure coordinate. The criteria for determining optimum sealing performance under test conditions was that, an electronic pressure transducer mounted on the Top (14) detected no leakage across the slide valve thirty (30) minutes after grease insertion. Every grid NOT filled indicates that some leakage occurred within the 30 minutes.

In order to perform a safe and efficient plate change operation, Emerson emphasizes that the on- site operator evaluate both the service and environmental conditions prior to selecting a lubricant. Additionally, Emerson realizes that some operators do allow leakage during a plate change operation for metal to metal valve seats based upon their experience and the service conditions under which they are operating and have performed successful and safe plate changes.

! WARNING

LEAKAGE OF TOXIC FLUID HAZARD

For Seniors with a soft-seated valve and grease-assisted slide valves, do not use the "QUICK CHANGE" procedure if the time to complete the plate removal and installation process will exceed 15 minutes.

Exceeding this time frame can allow leakage of possible toxic fluid from the seal. Failure to follow these instructions may result in death or serious injury.

One important factor for an owner or an operator to consider when selecting a grease for a particular application is plate change time. This is the period in minutes required for an operator to initiate, and complete, the Orifice Plate (13) change operation.

Refer to [Plate change procedure overview](#).

Figure 5-1: Standard grease - Type 1

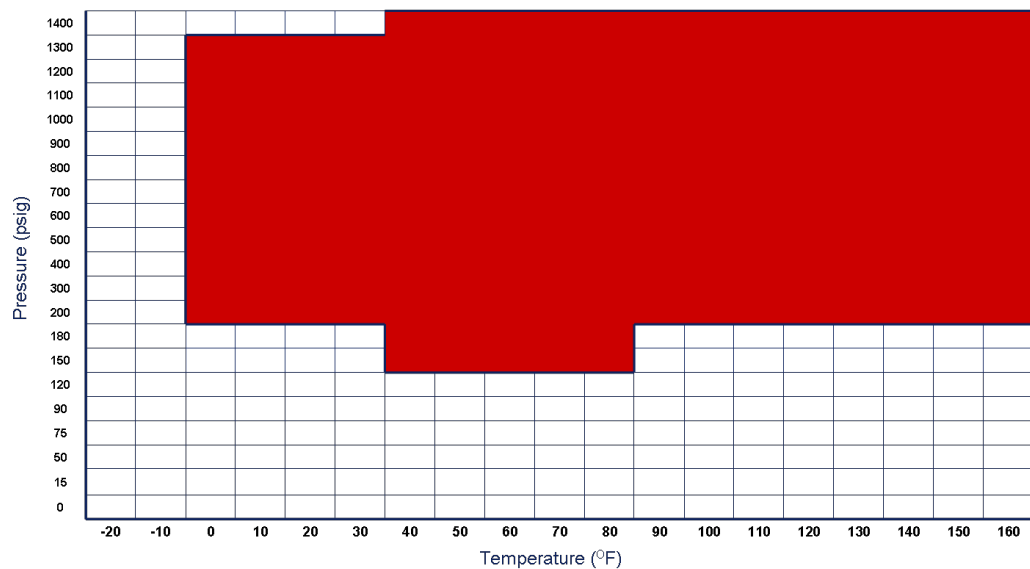

Pressure (psig) v. Temperature (°F) STANDARD GREASE - TYPE 1 - Part Number: 1-213-04-001 OPTIMUM SEALING RANGE WITH NITROGEN FOR A 3" ANSI 600 SENIOR FITTING UNDER LABORATORY CONDITIONS. Colored coordinate boxes indicate no detectable leakage at that Temperature and Pressure for 30 minutes.

This information can be used as a guideline when evaluating measurement applications. However, the pressure and temperature conditions to which a Senior may be exposed in an application may differ significantly from laboratory conditions.

Important

Customers should not rely solely on this information but rather must perform adequate testing on the particular application to confirm that the grease selected is appropriate for that application and will operate as intended.

Figure 5-2: Sour grease - Type 2

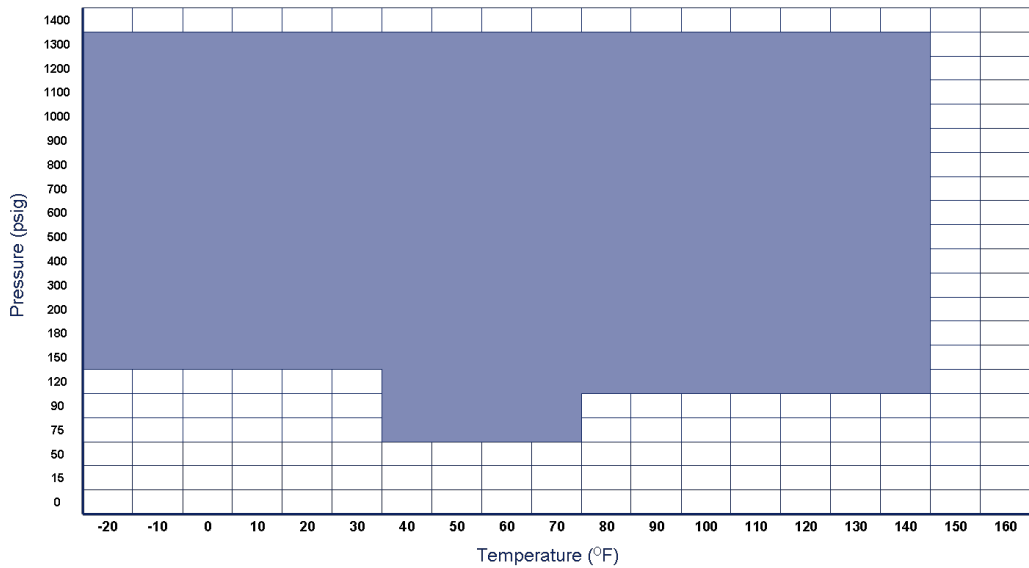

Pressure (psig) v. Temperature (°F) SOUR GAS GREASE - TYPE 2 - Part Number:1-213-04-102 OPTIMUM SEALING RANGE WITH NITROGEN FOR A 3" ANSI 600 SENIOR FITTING UNDER LABORATORY CONDITIONS. Colored coordinate boxes indicate no detectable leakage at that Temperature and Pressure for 30 minutes.

This information can be used as a guideline when evaluating measurement applications. However, the pressure and temperature conditions to which a Senior may be exposed in an application may differ significantly from laboratory conditions.

Important

Customers should not rely solely on this information but rather must perform adequate testing on the particular application to confirm that the grease selected is appropriate for that application and will operate as intended.

Figure 5-3: Carbon Dioxide grease - Type 3

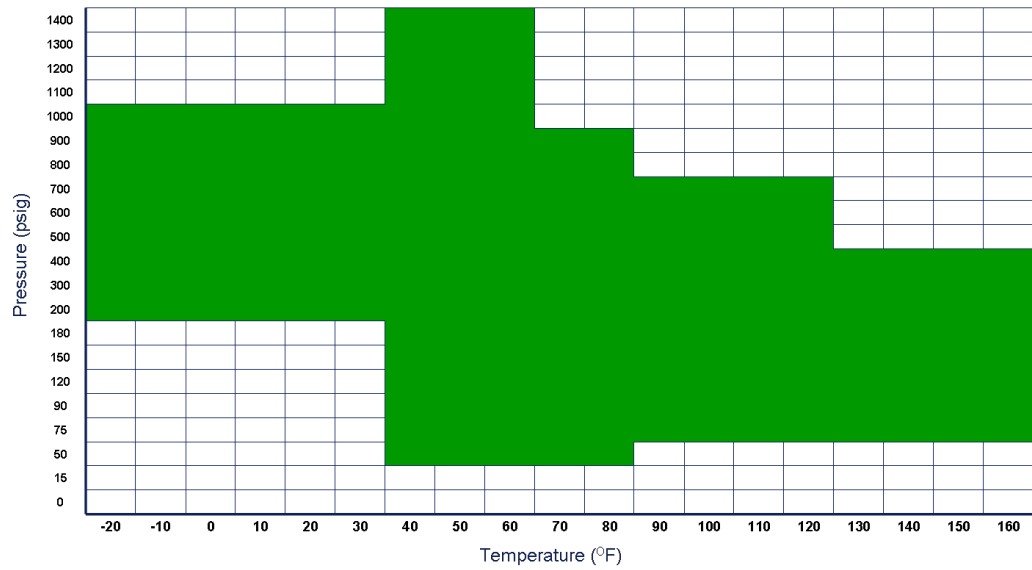

Pressure (psig) v. Temperature (°F) CARBON DIOXIDE GREASE - TYPE 3 - Part Number:1-213-04- 101 OPTIMUM SEALING RANGE WITH NITROGEN FOR A 3" ANSI 600 SENIOR FITTING UNDER LABORATORY CONDITIONS. Colored coordinate boxes indicate no detectable leakage at that Temperature and Pressure for 30 minutes.

This information can be used as a guideline when evaluating measurement applications. However, the pressure and temperature conditions to which a Senior may be exposed in an application may differ significantly from laboratory conditions.

Important

Customers should not rely solely on this information but rather must perform adequate testing on the particular application to confirm that the grease selected is appropriate for that application and will operate as intended.

Figure 5-4: High temperature grease - Type 4

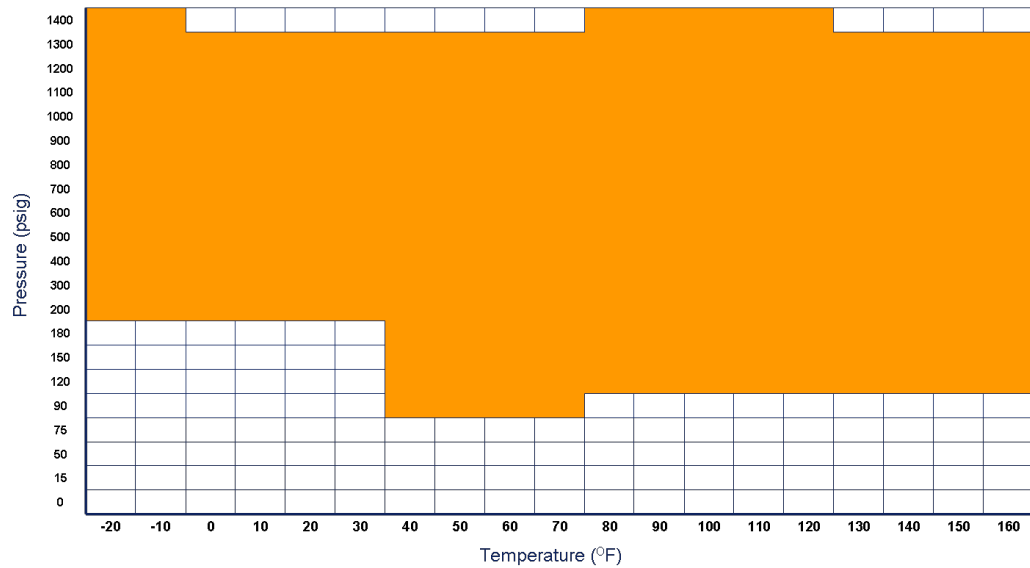

Pressure (psig) v. Temperature (°F) HIGH TEMPERATURE GREASE - TYPE 4 - Part Number:1-213- 04-103 OPTIMUM SEALING RANGE WITH NITROGEN FOR A 3" ANSI 600 SENIOR FITTING UNDER LABORATORY CONDITIONS. Colored coordinate boxes indicate no detectable leakage at that Temperature and Pressure for 30 minutes.

This information can be used as a guideline when evaluating measurement applications. However, the pressure and temperature conditions to which a Senior may be exposed in an application may differ significantly from laboratory conditions.

Important

Customers should not rely solely on this information but rather must perform adequate testing on the particular application to confirm that the grease selected is appropriate for that application and will operate as intended.

5.3 Torque information

Emerson utilizes several joint assemblies to construct a fitting. For a fitting to pass all factory tests, assembly personnel apply a specific torque to each fastener used in the fitting to ensure proper operation and to seal the unit. See [Table 5-3](#) in this section for suggested clamping bar screw torque values.

Product owners and product operators must realize that both time and service conditions impact the tightness and strength of joints originally assembled in the factory. Some, but not all, of these service conditions are:

- Time in service or storage
- Temperature cycles
- Vibration
- Mechanical loads

- Pressure loads
- Fastener thread condition (dirt/corrosion)
- Condition of joint assembly components (fasteners, gaskets, sealing surface conditions)
- Fastener lubrication and coatings

Emerson publishes these suggested torque values to help owners and users establish a starting point for applying torque to fasteners in service. The torque value applied to the clamping bar screws, necessary to achieve a seal, maybe greater or less than the suggested torque range in [Torque information](#).

Again, these values are only a reference. They are reference values because it is impossible for Emerson to know all of the variable conditions (some listed above) that your fitting (under your care) will see in actual service. Only the owner or operator, after careful consideration of a fitting's service conditions, can specify a torque value to achieve an adequate seal. Therefore, owners and operators are ultimately responsible for joint assembly torque specifications. Again, owners and users are to use the torque values given in the following table as reference only.

Apply the torque values that you select using the sequencing patterns provided in this section and in accordance with industry or company bolting procedures.

Table 5-3: Clamping bar screw (11) size and suggested torque values

These values are FOR REFERENCE only.

Screw size	Suggested torque range (lb-ft [N·m])		Maximum torque (lb-ft [N·m])
	Lower	Upper	
1/2"-13	75 [101]	120 [163]	130 [176]
5/8"-11	120 [163]	195 [264]	265 [359]

These torques values are to help users establish a starting point to provide adequate assembly and in-service clamping force in most applications. These values are FOR REFERENCE only.

DO NOT apply torque greater than the Maximum Torque value.

These torque values reflect new, heat treated, alloy steel (AISI 4140) screws.

Owners and operators are ultimately responsible for all joint assemblies within their system, including the clamping bar screws of the Senior fitting.

Figure 5-5: Torque pattern sequences

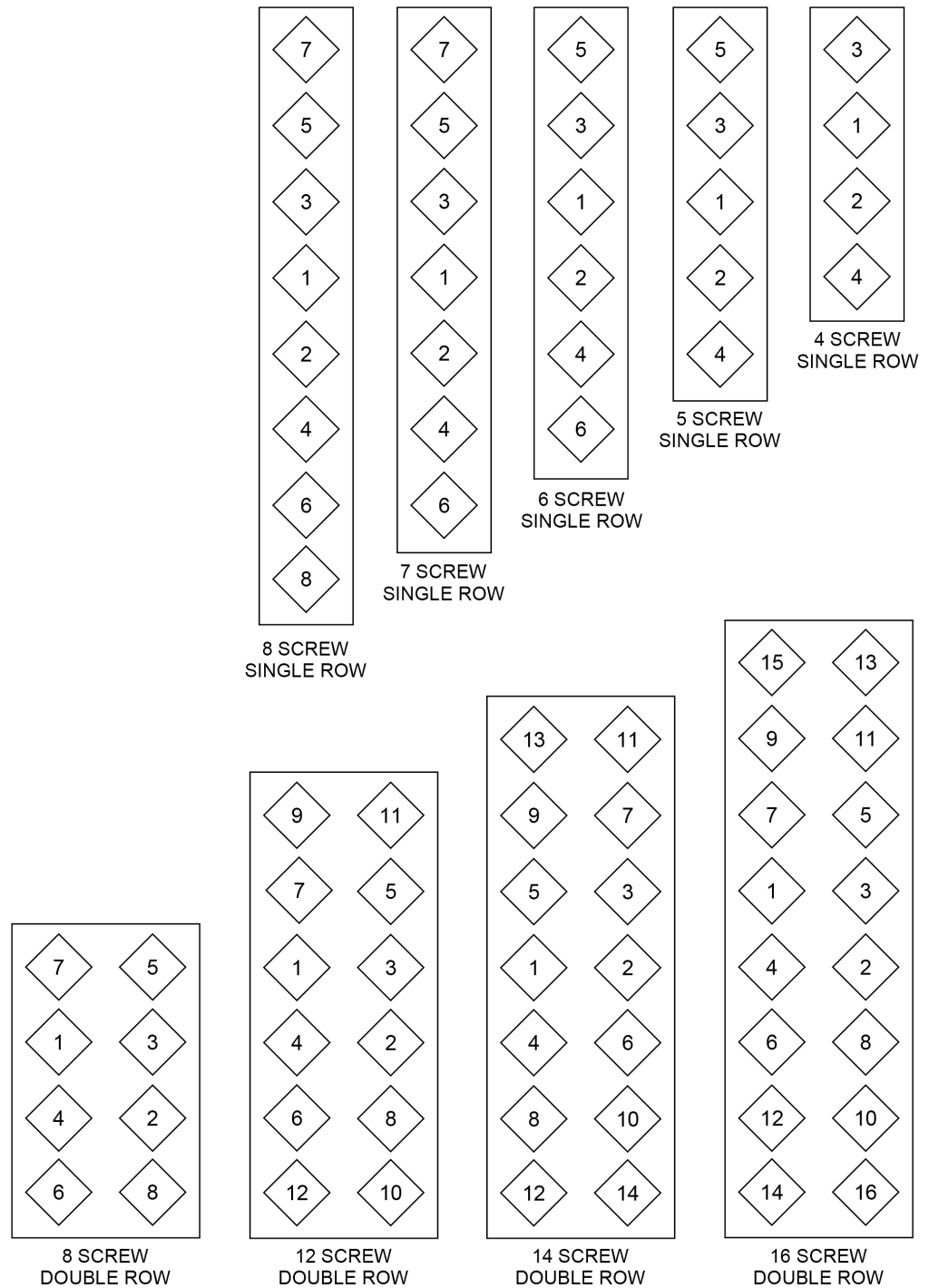
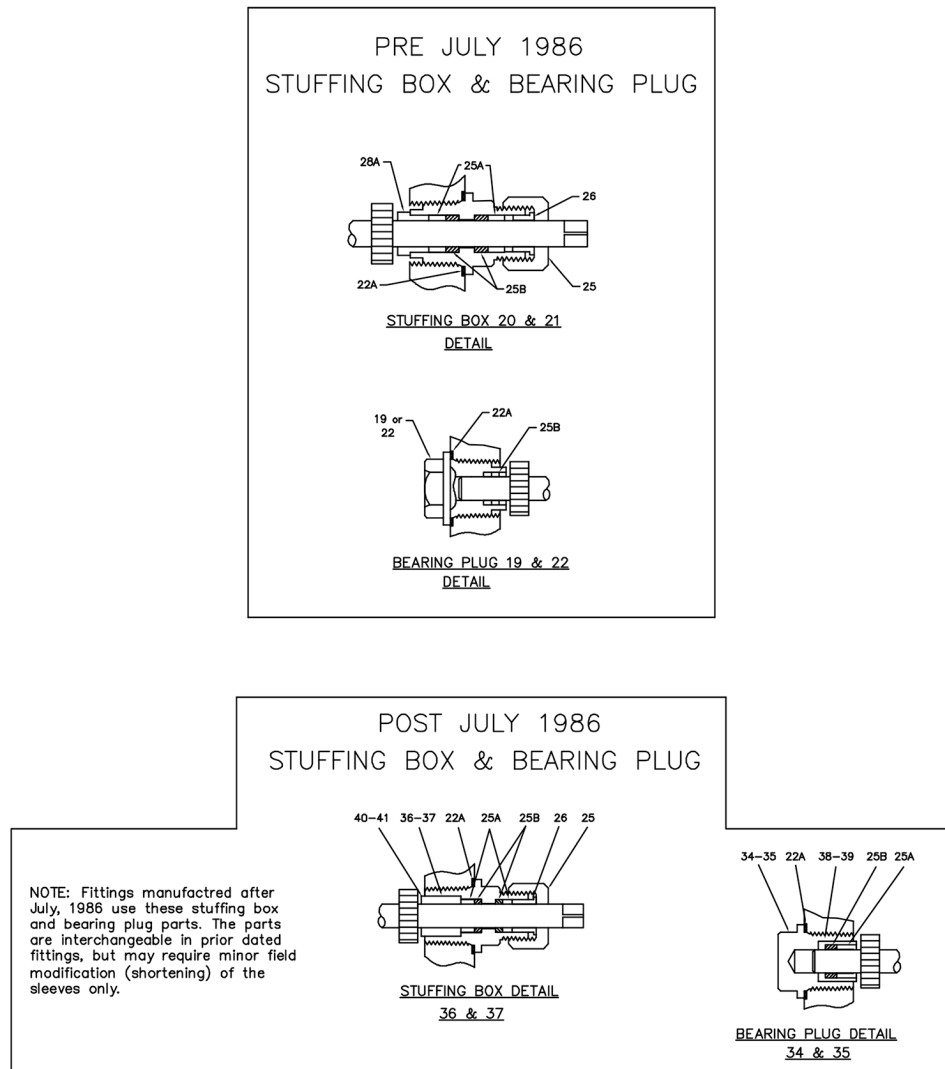

Figure 5-6: Stuffing box and bearing plug



5.4 Plate and Valve Carrier clearances

Table 5-4: Plate carrier to valve carrier clearances (inches)

Line size	Minimum clearance	Maximum clearance
2	.006	.018
3	.006	.018
4	.006	.018
6	.006	.018
8	.006	.018

Table 5-4: Plate carrier to valve carrier clearances (inches) (continued)

Line size	Minimum clearance	Maximum clearance
10	.008	.023
12	.009	.028
14	.010	.030
16	.012	.035

Emerson Automation Solutions

Daniel Measurement and Control, Inc.

North America / Latin America:

Headquarters

USA - Houston, Texas

T +1.713.467.6000

USA Toll Free 1.888.FLOW.001

[www.emerson.com/en-us/automation/
daniell](http://www.emerson.com/en-us/automation/daniell)

Europe: Stirling, Scotland, UK

T +44.1786.433400

Middle East, Africa: Dubai, UAE

T +971.4.811.8100

Asia Pacific: Singapore

T +65.6777.8211

©2019 Daniel Measurement and Control, Inc. All rights reserved. Unauthorized duplication in whole or part is prohibited. Printed in the USA.

Daniel Measurement and Control, Inc. ("Daniel") is an Emerson Automation Solutions business unit. The Daniel name and logo are trademarks of Daniel Industries, Inc. The Emerson logo is a trademark and service mark of Emerson Electric Co. All other trademarks are the property of their respective companies.

DANIEL™

