



780.897.5869
BURKECALIBRATION.COM

Texsteam 5100 Series Pneumatic Chemical Injection Pump

Questions? Call us at 780-897-5869 or email info@burkecalibration.com



series 5100

AIR OR GAS DRIVEN INJECTORS



Series 5100 LP
Wt. 45 pounds



Microswitch Option Available

DESCRIPTION

The 5100 Series Texsteam Chemical Injectors are single acting, positive displacement plunger-type pumps, powered by gas via a diaphragm with a spring return. Speed control is accomplished by regulating the exhaust gas discharge flow. Reversal is accomplished by a direct spring- actuated switching mechanism (rotary three-way valve). Volume is controlled by the speed of the pump and by the stroke length, either 1" or 1/3" lengths.

The 5100 Series is capable of pumping high pressures with gas pressure as low as 8 psi and handling volume output up to 30 gallons per day.

The pump is lightweight, compact and contains a minimum of working parts for easy maintenance. Each fluid pump head is equipped with a stainless steel plunger, ball checks, ball check springs, top seat, top bushing, bottom bushing, adjustable VEE type packing and a priming valve. The packing yoke is equipped with a drain to monitor for possible packing leaks. Because of the sealed bearings, the unit is oil-less.

The 5100 Series performs accurately because (1) the head is designed for high volumetric efficiency, (2) a positive trip mechanism assures fine control of plunger stroke length, and (3) the speed is regulated by controlling the exhaust gas discharge flow which creates a rapid fluid discharge with slow suction.

APPLICATIONS

- The introduction of de-emulsifiers, solvents, corrosion inhibitors, de-salting agents and flocculants in oil country operation
- High pressure bearing lubrication
- Water treatment
- Blending processes in refining and process plants
- Injection of methanol in gas pipelines
- Hydrostatic testing
- Sampling

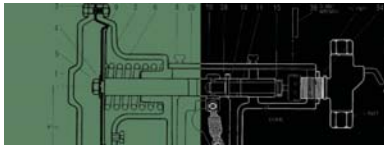

ACCESSORIES, OPTIONS, & VOLUME

Sour Gas Trim - Pump models L and LP are furnished with sour gas trim as standard. Models H and HP are available for sour gas service specification.

TB-40 Regulator - for inlet gas pressure greater than 35 PSI and up to 1500 PSI

Alternate Parts - Teflon, Viton, or Fluorosilicone packing, hastelloy balls.

Plunger Size	Maximum Discharge Pressure	GPD = gallons per day	
		For Operation Off Air or Gas Pressure to 33 PSI Constant Power Unit ¹	
5100 Series (Standard Packaging)		Model Number	Maximum Volume
3/16"	1500 PSI	5104	4.2 GPD
1/4"	1500PSI	5101	7.5 GPD
3/8"	1500PSI	5103	16.8 GPD
1/2"	1500PSI	5105	32.0 GPD
(High Pressure Packing)		Model Number	Maximum Volume
3/16"	6000PSI	5104	2.8 GPD
1/4"	6000PSI	5101	5.0 GPD
3/8"	6000PSI	5103	12.0 GPD
1/2"	3500PSI	5105	22.0 GPD

1. Basic pump no tank, base, regulator, gauge (Shipping Weight: 45 lbs.)
 2. Furnished with 5 gallon stainless steel tank mounted on heavy galvanized steel base and equipped with level gauge and suction line but no regulator or gauge (Shipping Weight: 60 lbs.)
 3. Furnished with regulator and gauge but no tank or base (Shipping Weight: 48 lbs.)
 4. Furnished with 5 gallon stainless steel tank mounted on heavy galvanized steel base and equipped with level gauge, suction line, regulator and gauge (Shipping Weight: 62 lbs.)
- *Volumes shown for low pressure heads with standard packing are at zero PSIG discharge pressure.
 **Volumes For high pressure head with hard packing are shown at 1500 PSIG discharge pressure.

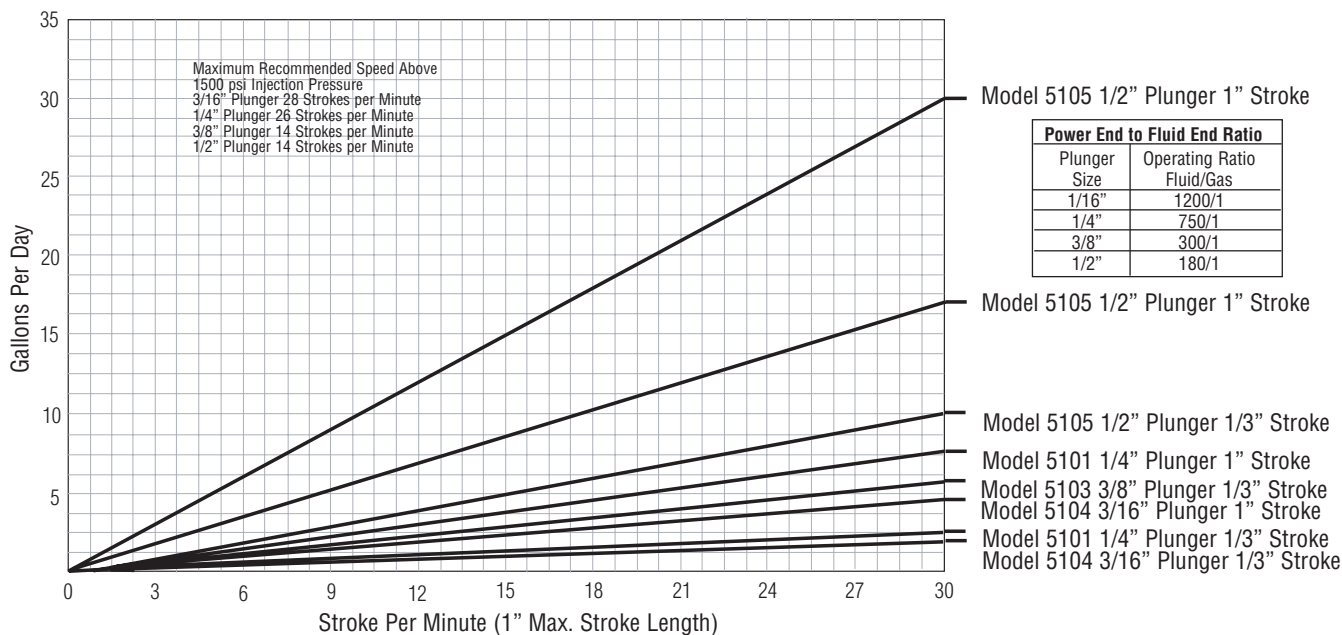

GAS CONSUMPTION CHART

(Standard Cubic Feet of Gas Required to Pump One Gallon) For inlet regulator sizing, double the requirement indicated

Injection Press in PSI		100	200	500	1000	1500	2000	3000	3500	4000	5000	6000
1/2" Plunger 1" Stroke	5105	53	54	57	62	71	76	84	95			
1/2" Plunger 1/3" Stroke		159	162	171	186	213	228	252	285			
3/8" Plunger 1" Stroke	5103	120	126	148	164	177	185	243	278	314	355	374
3/8" Plunger 1/3" Stroke		360	378	444	492	531	555	729	834	942	1065	1122
1/4" Plunger 1" Stroke	5101	244	245	248	270	288	308	340	355	369	405	497
1/4" Plunger 1/3" Stroke		732	735	744	810	864	924	1020	1065	1107	1215	1491
3/16" Plunger 1" Stroke	5104	457	458	462	469	476	530	545	555	560	575	589
3/16" Plunger 1/3" Stroke		1371	1374	1386	1407	1428	1590	1635	1665	1680	1725	1776

AIR OR GAS DRIVEN INJECTORS

series **5100**

INSTALLATION

IMPORTANT:

**Max. Gas Diaphragm Chamber Pressure 35 P.S.I.
Oil thrust rod occasionally.**

1. Remove pump from carton and inspect for possible damage in transit from factory. The cardboard carton was designed especially for this pump and offers ample protection for normal handling. If the pump has been damaged in transit, file claim with the carrier.
 2. Loosen and remove the four thumb screws that hold the cover.
 3. Oil the thrust rod.
 4. Select the stroke length desired, either full or short according to your requirements. See the data chart, full stroke is 1", and short stroke is equal to 1/3".
 5. Check plunger packing gland to make sure packing is 1/4 turn past finger tight.
 6. Install the priming valve TA-1497 in its position on the pump head.
 7. Blow or clean line before hooking up air or gas line to inlet. On models 5100 LP and 5100 L the air or gas line (if it does not exceed 35 psi) is piped directly into the inlet TA-906. The inlet is a 1/4" female connection. Do not hook up the gas supply to the small valve. This is the gas exhaust, Gas supply should be constant pressure to assure even stroke speed.
- If the gas supply pressure exceeds 35 psi or is erratic, some means of reducing the gas pressure to below 35 psi must be used. Model 5100 HP and 5100 H are equipped with a pressure regulator and pressure gauge for reducing the gas pressure. The regulator supplied with the 5100 HP and 5100 H can be used up 400 psi. If the gas supply pressure exceeds 400 psi, the customer should equip the pump with a Texsteam TB-40 regulator which has a maximum inlet pressure of 1500 psi.
8. Close gas exhaust valve. The gas exhaust is a 1/4" female pipe connection.
 9. Hook up the fluid suction piping to the bottom bushing on the pump head. This is a 1/4" female pipe connection. Care should be exercised in that a suitable strainer should be installed in the suction line to trap foreign matter that might injure the plunger, plunger packing or interfere with the check valve operation.
 10. On hooking up the fluid discharge line, the top connection on the pump head is the outlet and it is a 1/4" FNPT. The discharge line should be at least 5/16" tubing and a TA-676 line check should be installed at the point of injection in case the fluid discharge line ruptures or is broken. Careful observation of the flow direction during installation will eliminate the possibility of a ruptured fluid discharge line.
 11. Turn the gas on and slowly open the gas exhaust valve. The pump will start automatically. Make certain the suction line is filled with fluid by opening the priming valve to check for fluid. After the pump discharges clear fluid without bubbles, close the priming valve for normal pumping operations. At this point make a visual check of the plunger drip and using the TA-315 gland wrench, slowly tighten the gland nut until leakage just stops. It may be necessary to readjust the packing the next day. A slight leak during break-in is beneficial. Sufficient time should be allowed to let the packing "seat in". Packing should only be adjusted after pressure has been removed from the pump head. Never adjust packing against pressure.
 12. After the pump is in operation, replace the cover and thumb screws.

START UP AND OPERATION

After the pump has been installed, only a few minor adjustments are necessary for every day operation. Here are a few check points.

1. Check gas supply pressure.
2. Check speed control with the chart which will give you the volume the pump is injecting.
3. Check for excess leakage around the packing gland. If is not possible to stop excess leaking, replace the packing. If the plunger is badly scored, replace the plunger. Do not adjust packing against pressure.
4. Open the priming valve to check pump action.
5. Oil thrust rod occasionally.



MAINTENANCE

Should the pump run but fail to pump chemical, remove TB-736 bottom bushing and TA-1496 top bushing - inspect and clean balls and seats. Inspect for damage and replace if necessary. Should pump still not pump chemical, remove TB-548 cover and check to see if TA-290 Cotter Pin and TA-1828 Stroke Adjusting Pin are in place.

Check to see if chemical is getting to pump, unscrew TA-1497 priming valve stem. When chemical flows from bleed hole, shut TA-1497 priming valve.

If the pump fails to operate after hooking up gas or air to TA-906 (inlet bushing); make sure the inlet pressure does not exceed 35 psi - excessive pressure could tend to lock the pump; make sure the speed control valve (gas exhaust) is open; and make sure the plunger packing is not too tight. Use gland wrench TA-315 to adjust packing gland nut TA-6353, if necessary.

If pump stops and a constant flow of gas comes from TA-1835 air vent, this means that the TC-2128 diaphragm has ruptured.

TO REPLACE DIAPHRAGM

Remove TC-252 diaphragm cover. Remove lock nut and washer on end of TB-444. Do not allow TB-444 thrust rod to turn when removing lock nut and washer. To prevent the rod from turning, remove TB-548 cover and hold the rod in position by inserting punch or drift pin into the "large" hole forward of the TA-6564 Stirrup assembly. Replace burst diaphragm and reassemble.

TO REPLACE RETURN SPRING

Remove TC-252 diaphragm cover - remove lock nut and washer on end of TB-444 thrust rod. It is important that you do not allow TB-444 thrust rod to return when moving lock nut and washer. To prevent the rod from turning remove TB-548 cover and hold the rod in position by inserting punch or drift pin into the "large" hole forward of the TA-6564 stirrup assembly.

Pull TC-2128 diaphragm – TB-438 diaphragm plate - return spring TA-1821 can then be removed. Reassemble in reverse of above.

REPLACING TA-4147 VALVE DISC ASSEMBLY

If the pump has a heavy continuous leaking of gas – TA-4147 valve disc assembly probably needs

replacing. Disconnect power supply into TA-906 disc retainer. Remove TA-906 Disc retainer from TA-441 body - caution: care should be taken not to lose TA-77 valve spring and TA-579 washer located directly under TA-906 disc retainer.

Before removing, note the position of the TA-4056 valve disc, so that the disc is replaced to the same position as it was removed (see page 8). Lap the TA-4056 disc with a good valve grinding compound before replacing.

When replacing TA-4056 valve disc be sure to also replace the TA-4062 drive pin that was supplied when you ordered the disc assembly.

REMOVING TB-446 VALVE ASSEMBLY FROM PUMP HOUSING

Should it be necessary to remove TB-1631 flipper arm assembly from the pump housing, disconnect TB-1193 SS tubing, the power inlet from TA-906 disc retainer and the gas exhaust line. Remove the four P01-031100-3900 machine screws and four P52-031000-3900 lock washers. The TB-446 valve assembly can then be withdrawn from pump body.

The flipper arm bearing is an integral part of the TB-1631 flipper arm assembly and is press fit into the TB-441 body. A punch must be used to remove the flipper arm from the valve body. To do this the procedure under the heading, "Replacing TA-4147 Valve Disc Assembly." must be performed. When these parts are removed the TB-1631 flipper arm assembly may be punched from the body.

Upon reassembling the lower shaft of the TB-1627 flipper arm must fit into the TA-6563 flipper spring adapter.

TO REPLACE THE FLIPPER SPRING

Follow the procedure as outlined under "Removing TB-446 Valve Assembly from Pump Housing."

After removing the valve assembly, remove TB-548 cover. At this point TA-6564 stirrup assembly may be turned upside down on the thrust rod - unscrew TA-1820 flipper spring. To reassemble follow the above procedure in reverse.

AIR OR GAS DRIVEN INJECTORS

series **5100**

LP & HP

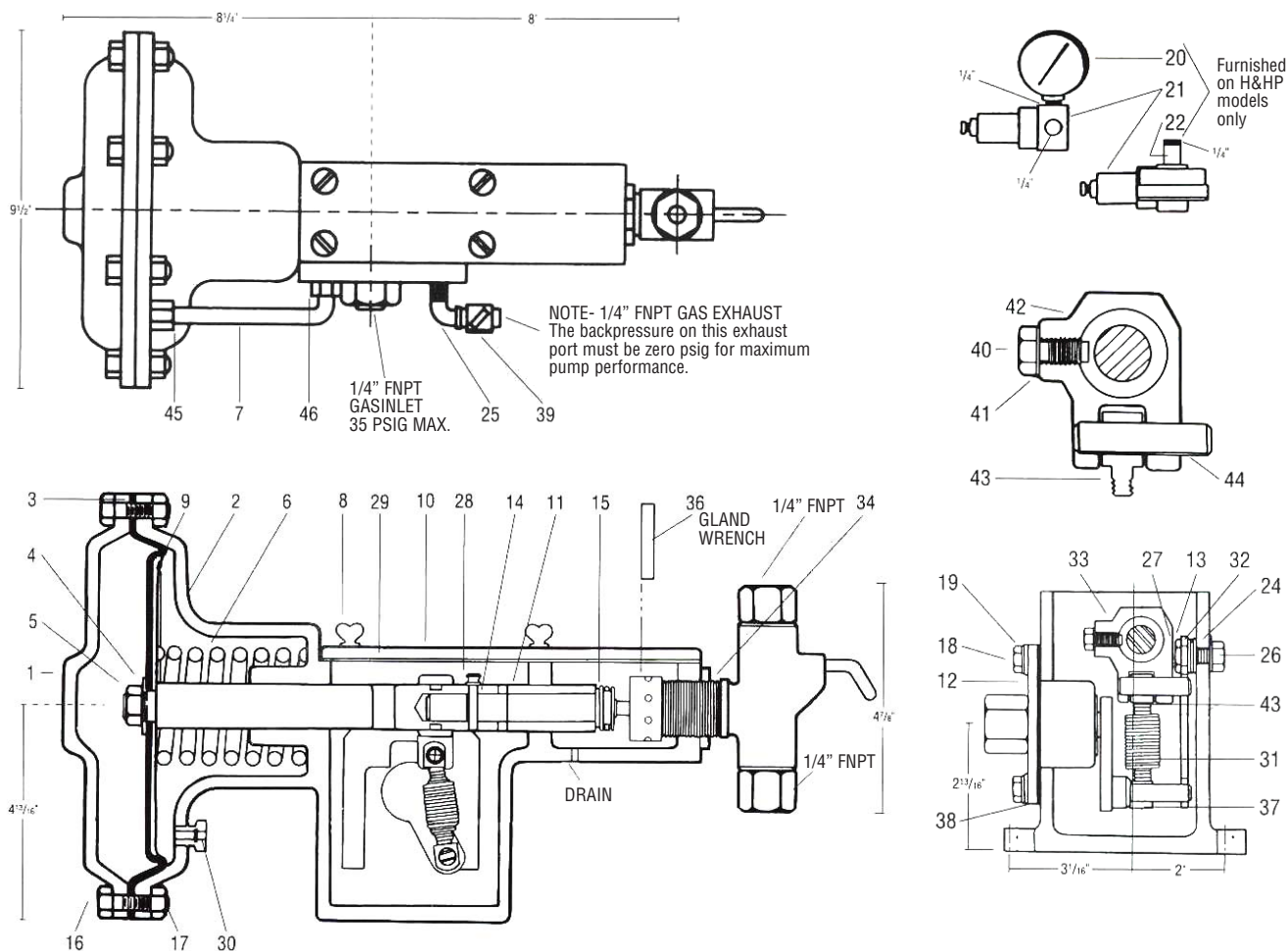

PARTS LIST

Item	Part No.	No. Reqd.	Name	Material
1	TC-0252	1	Diaphragm Cover	Cast Iron
2	TD-0251	1	Housing	Cast Iron
3**	TC-2128	1	Molded Diaphragm	Buna-N, Nylon
4	P54-062000-0200	1	Washer	Stl. Zinc Pl.
5	TA-3320	1	Locknut	Stl. Zinc Pl.
6**	TA-1821	1	Return Spring	C.S. Zinc Pl.
7	TB-1193	1	Pilot Valve Line Assy.	303 S.S. Tubing
8	P86-025075-0200	4	Wing Screws	Stl. Zinc Pl.
9	TB-0438	1	Diaphragm Plate	Steel
10	TB-0548	1	Cover	Cast Iron
11	TB-0444	1	Thrust Rod	Steel
12	TB-0446	1	Pilot Valve	See Page 7
13	TA-1823	1	Bumper Plate	Steel
14	TB-0447	1	Rod Adapter	Steel
15	TA-0290	1	Pin	Steel
16	P01-037125-3900	8	Hex Hd. Cap Screw	SS
17	P25-037000-3900	8	Hex Nut	SS
18	P01-031100-3900	4	Hex Hd. Mach. Screw	SS
19	P52-031000-3900	4	Lockwasher	SS
20*	TA-1854	1	Pressure Gauge Range 0-35 psig	Brass Element
21*	TA-1718	1	Regulator	Aluminum/Brass
22*	TA-3324	1	Nipple	Stl. Zinc Pl.

Item	Part No.	No. Reqd.	Name	Material
24	P52-037000-3900	1	Light Lockwasher	SS
25	TA-0075	1	Street El.	C.S. Galv.
26	P26-037000-0200	1	Hex. Nut	Semifinish Stl. Zinc Pl.
27	TA-1827	1	Bumper Plate Screw	Steel
28*	TA-1828	1	Adjusting Pin	Steel
29*	TA-1546	1	Gasket	Buna-N
30	TA-1835	1	Air Vent	Brass
31**	TA-1820	1	Flipper Spring	Steel
32**	TA-0746	3	Washer	C.S. Zinc Pl.
33	TA-6564	1	Stirrup Assembly	Cast Iron & Steel
34		1	Injector Head	Head Assemblies (See page 8 for part list)
36**	TA-0315	1	Gland Wrench	Steel
37**	TA-6563	1	Spring Adapter (Bottom)	Steel
38**	TA-0058	1	Gasket-Pilot Valve	Fiber
39	TA-2489	1	Gas Exhaust Valve	Ni. Plated Brass
40	TA-1829	1	Hex. Hd. Screw	Steel
41	P51-037000-0200	1	Internal Tooth Lockwasher	Carbon Stl. Zinc Pl.
42	TB-0471	1	Trip Stirrup	Cast Iron
43**	TA-6563	1	Spring Adapter (Top)	Steel
44**	TA-2355	1	Rollpin	Steel
45	TA-4015	1	Male Con. & Comp. Nut	C.S. Cad. Pl.
46	TA-4016	1	Elbow Con. & Comp. Nut	C.S. Cad. Pl.

NOTES:
* Furnished on H & HP models only
** Recommended spare part
*** Parts not mounted - packaged with unit

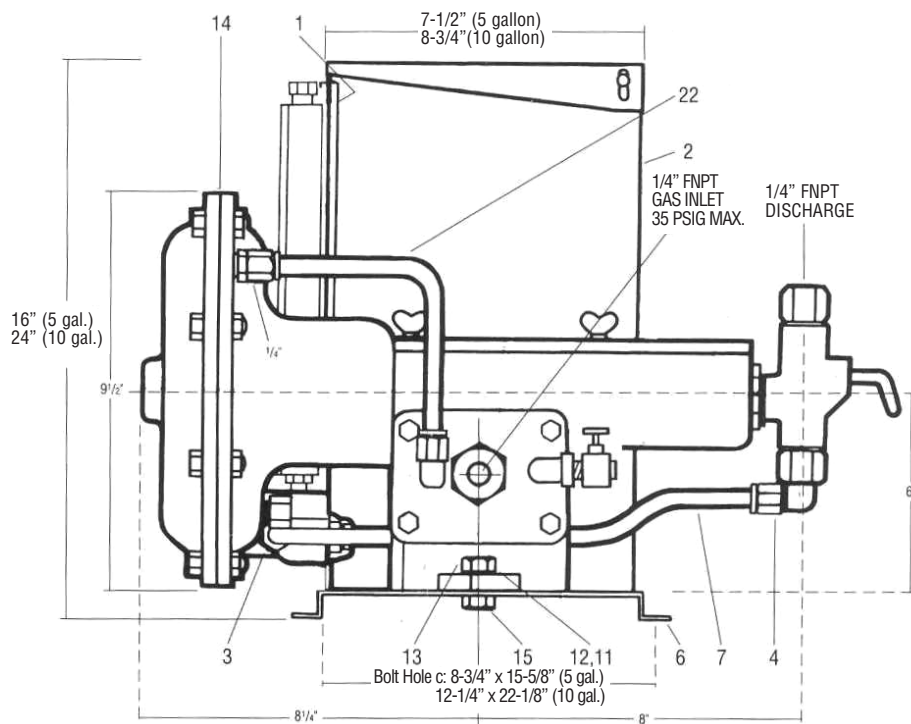
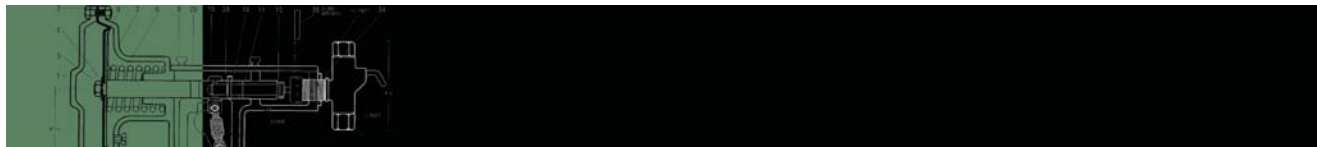

PARTS LIST

Item	Part No.	No. Reqd.	Name	Material
1	TA-0529	1	Gauge Stick 5 Gallon	Stainless Steel
1	TA-1742	1	Gauge Stick 10 Gallon	Stainless Steel
2	TA-0664	1	5 Gallon Tank	430 Stainless Steel
2	TA-1539	1	10 Gallon Tank	304 Stainless Steel
3	TA-3118	1	Connector	Polypropylene
4	TA-3116	1	Elbow Connector & Compression Nut Assy.	Polypropylene
5*	TB-0038	1	Sight Feed Assembly	Optional and in lieu of Item 25
6	TA-0950	1	Base, 5 Gal.	Steel
	TB-0758	1	Base, 10 Gal.	Steel
7	TA-3123	1	Suction Line	5/16"x22" Polypropylene
9**	TA-2459	1	Screen	Stainless Steel
10	TA-0792	1	Bushing	Brass
11	P53-031000-0200	4	Cut Washer	C.S. Zinc Pl.
12	P52-031000-3900	2	Lockwasher	SS
13	P25-037000-3900	2	Hex Nut	SS
15	P01-031100-3900	2	Hex Head Cap Screw	SS
16**	P10-031125-0200	1	Pan Hd. Slotted Machine Screw	Steel Zinc Pl.
17**	TA-0098	1	Bowl	Glass
18	TA-0206	1	Strainer	Monel
19**	TA-0104	1	Bowl Gasket	Fiber
20	TB-0039	1	Sight Feed Body	Aluminum
21	TA-0101	1	Shut off Assembly	Brass
25	TB-0871	1	Tank Gauge, 5 Gal.	Assembly
	TB-1285	1	Tank Gauge, 10 Gal.	Assembly

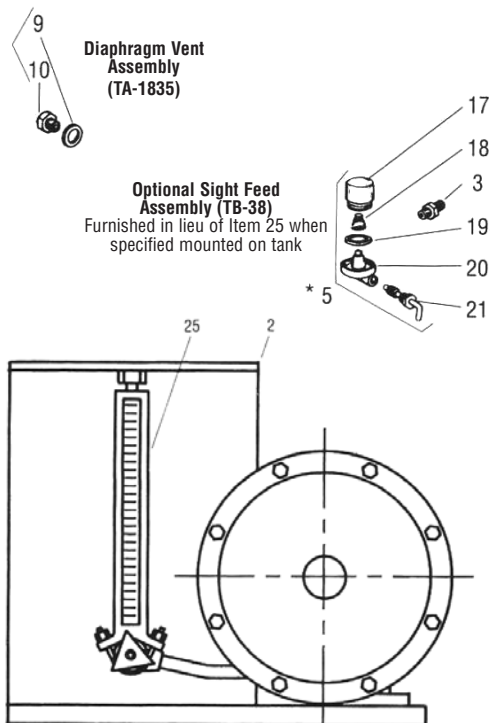

* Optional. Will be supplied in lieu of Item 25, Tank Gauge
 ** Recommended spare part
 *** Between pump and resevoir (same relative position as Item 13)

AIR OR GAS DRIVEN INJECTORS

series **5100**

PILOT VALVE ASSEMBLY

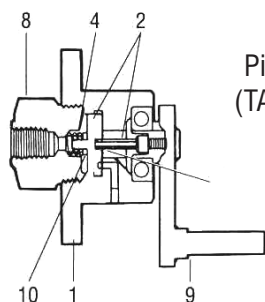

Pin Only
(TA-4062)

***NOTE:** To assemble, move lever arm to left as shown and align hole in pilot valve disc with hole in pilot valve body.

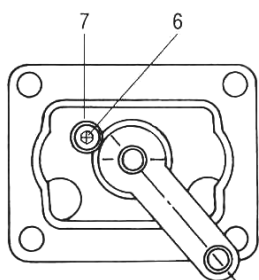

Backside View

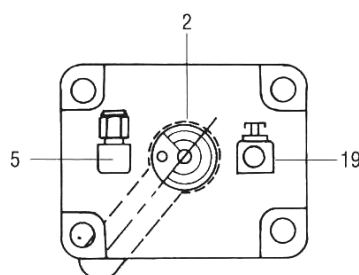

Outside View

PARTS LIST

Item	Part No.	No. Reqd.	Name	Material
1	TB-0441	1	Body	Cast Iron
2	TA-4147 TA-4062	1	Valve Disc and Drive- Pin Assy. Pin Only	17-4 Ph SS Steel Hardened
4*	TA-0077	1	Valve Spring	Stainless Steel
5	TA-4016	1	Elbow Connector & Compression Nut Assy.	C.S. Zinc Plated
6	P03-025037-0200	1	Hex Socket Cap Screw	Steel
7	P53-025000-0200	1	Washer	C.S.
8	TA-0906	1	Disc Retainer	C.S. Zinc Plated
9	TB-1631	1	Flipper Arm & Bearing Assy.	17-4 SS Flipper Arm with C.S. Bearing
10*	TA-0579	1	Washer	Stainless Steel
11	TA-0677	1	Outlet Body	Brass
12*	TA-0391	1	Spring	Stainless Steel
13*	TA-0054	1	Ball	Stainless Steel
14*	TA-2093	1	O-Ring	Viton
	TA-0479	1	O-Ring	Buna-N
15	TA-0678	1	Inlet Body	Brass
16	TA-1296	1	Outlet Body	Stainless Steel
17	TA-1297	1	Inlet Body	Stainless Steel
18*	TA-1574	1	Gasket	Stainless Steel
19	TA-2489	1	Valve	Brass, Ni Plated

** Recommended Spare Part

Parts Required for Sour Gas Applications
Furnished Only When Ordering Pump
Models H and AP for Sour Gas Applications

Page No.	Item	Part No.	No. Reqd.	Name	Material
5	20	TA-2847	1	Pressure Gauge 0-60 psig	S.S. Element
5	21	TA-2845	1	Regulator 250# max. inlet	Aluminum

Brass Line Check
(TA-676)

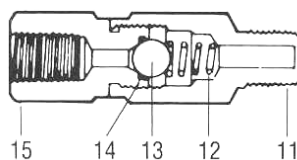

303 SS Line Check
(TA-675)

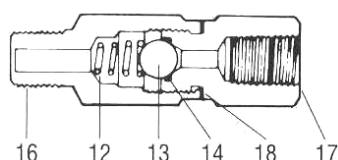

TB-871
Tank Gauge
For 5 Gal. Tank

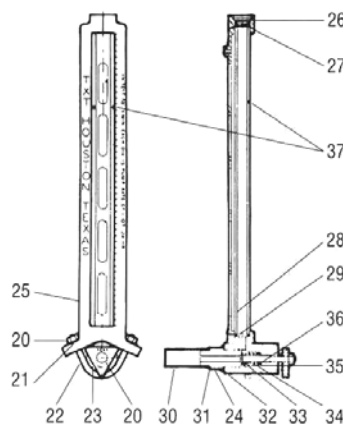

Item	Part No.	Name
1**	TA-0200	Upper Valve Seat
20	P25-025000-0200	Nut
21	P55-025000-3900	Washer
22	TA-3106	U-Bolt
23	TA-3112	Handle Valve
24*	TA-3199	O-Ring, Viton
25	TC-0393	Frame, Alum.
26*	TA-3100	Spring, 303 SS
27*	TA-3101	Flat Washer
28*	TA-3102	Gauge Glass
29*	TA-2184	O-Ring, Viton
30	TA-3103	Strainer, 303 SS
31	TA-3104	Retainer Nut, 303 SS
32	TA-3115	Valve Body, 303 SS
33	TA-3144	Stem Valve, 303 SS
34	TA-3113	Spring, 316 SS
35	TA-3328	Washer, 303 SS
36	TA-3107	O-Ring, Viton
37	TA-2163	O-Ring, Buna-N

*TB-874 Repair Kit parts

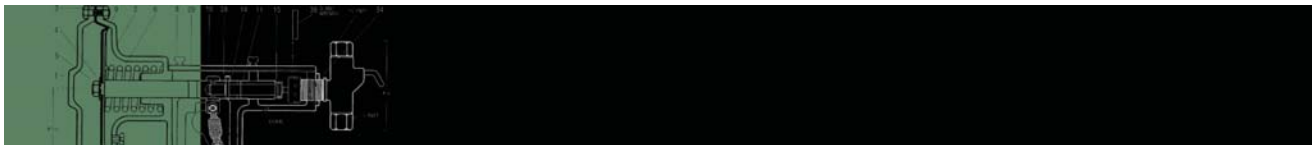

PARTS LIST

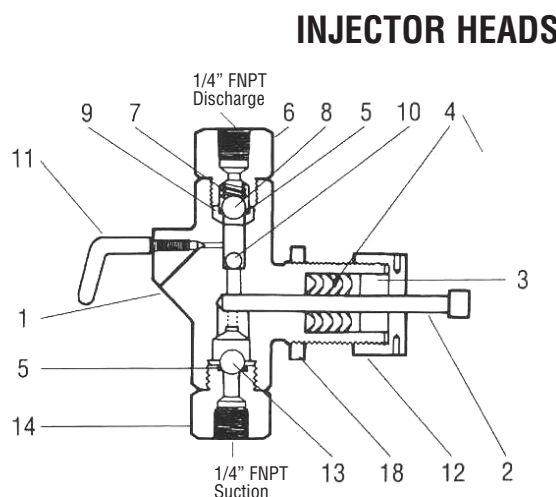
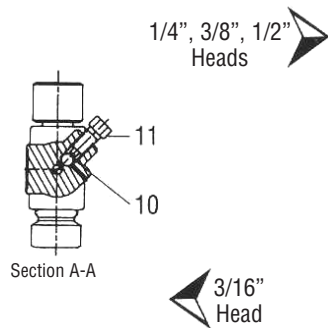
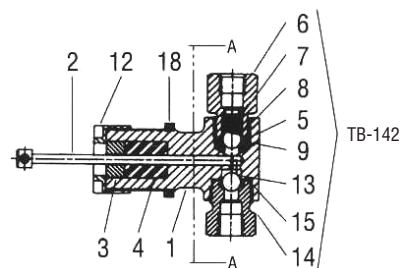

INJECTOR HEADS

Plunger Size/Model #			3/16" 5104		1/4" 5101		3/8" 5103		1/2" 5105	
Item No.	Material Specification	Material Construction	All Stainless Steel**	Ductile w/SS Trim	All Stainless Steel	Ductile w/SS Trim	All Stainless Steel	Ductile w/SS Trim	All Stainless Steel	
	Head Assembly No.		TB-1472	TB-0166	TB-0755	TB-0203	TB-0756	TB-0496	TB-0732	
1	Body		TC-2040	TC-0275	TC-0291	TC-0276	TC-0425	TC-0272	TB-0349	
2*	Plunger	17-4 PH	TA-5643	TA-1312	TA-1312	TA-1745	TA-1745	TA-1876	TA-1876	
3	Plunger Packing Gland	303-SST	TA-5642	TA-1463	TA-1463	TA-0957	TA-0957	TA-1219	TA-1219	
4*	Plunger Packing (see table below for maximum discharge pressures)	Buna-N	TA-3969	TA-1461	TA-1461	TA-1456	TA-1456	TA-0959	TA-0959	
		Buna-N Hard	TA-3948	TA-2295	TA-2295	TA-1875	TA-1875	TA-1874	TA-1874	
		Viton	TA-3967	TA-4102	TA-4102	TA-4101	TA-4101	TA-4103	TA-4103	
		Viton Hard	TA-6253	TA-6555	TA-6555	TA-6556	TA-6556	TA-6557	TA-6557	
		Teflon	TA-3966	TA-1642	TA-1642	TA-1234	TA-1234	TA-1012	TA-1012	
5*	O-Ring, Suction & Discharge (included in items 8 & 14)	Buna-N	TA-0479	TA-0479	TA-0479	TA-0479	TA-0479	TA-0479	TA-0479	
		Viton	TA-2580	TA-2580	TA-2580	TA-2580	TA-2580	TA-2580	TA-2580	
		Teflon	TA-6159	TA-6159	TA-6159	TA-6159	TA-6159	TA-6159	TA-6159	
		Fluorosilicone	TA-4113	TA-4113	TA-4113	TA-4113	TA-4113	TA-4113	TA-4113	
		Kalrez	TA-5037	TA-5037	TA-5037	TA-5037	TA-5037	TA-5037	TA-5037	
6	Top Bushing	302-SST	TA-1496	TA-1496	TA-1496	TA-1496	TA-1496	TA-1496	TA-1496	
		316-SST	TA-0077	TA-0077	TA-0077	TA-0077	TA-0077	TA-0077	TA-0077	
7*	Ball Check Spring	316-SST	TA-0077	TA-0077	TA-0077	TA-0077	TA-0077	TA-0077	TA-0077	
8*	Large Top Ball 3/8"	316-SST	TA-0054	TA-0054	TA-0054	TA-0054	TA-0054	TA-0054	TA-0054	
		Hastelloy	TA-0064	TA-0064	TA-0064	TA-0064	TA-0064	TA-0064	TA-0064	
9*	Top Seat-Assembly Buna-N "O" Ring	303-SST	TB-0737	TB-0737	TB-0737	TB-0737	TB-0737	TB-0737	TB-0737	
	Top Seat-Assembly (Metal-to-Metal)	303-SST	N/A	TA-0806	TA-0806	TA-0806	TA-0806	TA-0806	TA-0806	
10*	Small Top Ball 1/4"	316-SST	N/A	TA-0126	TA-0126	TA-0126	TA-0126	TA-0126	TA-0126	
11	Priming Valve	303-SST	TA-5462	TA-1497	TA-1497	TA-1497	TA-1497	TA-1497	TA-1497	
12	Nut, Plunger Packing Gland	303-SST	TA-6353	TA-6353	TA-6353	TA-6353	TA-6353	TA-6353	TA-6353	
		316-SST	TA-0054	TA-0054	TA-0054	TA-0054	TA-0054	TA-0054	TA-0054	
13	Suction Ball 3/8"	316-SST	TA-0054	TA-0054	TA-0054	TA-0054	TA-0054	TA-0054	TA-0054	
		Hastelloy	TA-0064	TA-0064	TA-0064	TA-0064	TA-0064	TA-0064	TA-0064	
14*	Bottom Seat Bushing Metal-to Metal (Use w/TA-0053 1/2" Ball Only)	316-SST	N/A	TB-0053	TB-0053	TB-0053	TB-0053	TB-0053	TB-0053	
		303-SST	TB-1216	TB-0736	TB-0736	TB-0736	TB-0736	TB-0736	TB-0736	
15	Gasket	304-SST	TA-4394	N/A	N/A	N/A	N/A	N/A	N/A	
18	Locknut	Brass	TA-0225	TA-0225	TA-0225	TA-0225	TA-0225	TA-0225	TA-0225	

*Recommended Spare Parts
 ** Ductile not Available

Plunger Packing - Max Discharge Pressure

Material	Pressure psig			
	3/16"	1/4"	3/8"	1/2"
Buna-N	3000	3000	3000	3000
Buna Head	6000	6000	6000	3500
Viton Hard	6000	6000	6000	3500
Viton	3000	3000	3000	3000
Teflon	3000	3000	3000	3000

AIR OR GAS DRIVEN INJECTORS

series **5100**

5100 MICROSWITCH VALVE INSTALLATION

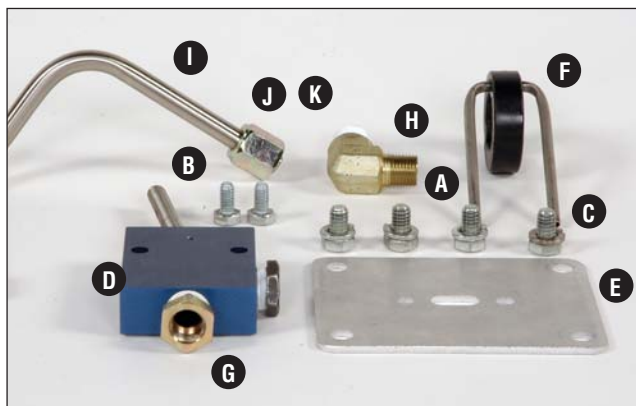

TA 7093 Microswitch Valve Kit

Item	Part No.	Name	Material
A.	P01-031050-0200	HHCS	C.S. Zinc Pl.
B.	P01-025050-0200	HHCS	C.S. Zinc Pl.
C.	P52-031000-0200	Lockwasher	C.S. Zinc Pl.
D.	TA 7091	Microswitch	Aluminum
E.	TA 7088	Microswitch Mounting Plate	Aluminum
F.	TA 7090-1	Thrust Collar Assembly	
G.	TA 7095	Bushing	C.S. Zinc Pl.
H.	TA 7096	Elbow	C.S. Zinc Pl.
I.	TA 7092	Tubing	S.S.
J.	TA 7097	Ferrule	C.S. Zinc Pl.
K.	TA 7098	Flareless Nut	C.S. Zinc Pl.

INSTALLATION

1. If pump is installed in the field, shutoff gas flow to the pump.
2. Disconnect the gas supply pipe from the TA-0906 disc retainer gas inlet to the pump. Disconnect and remove the TB 1193 pilot valve line assembly as shown below.
3. Remove the four P01-031-3900 machine screws and four P52-031000-3900 lock washers and remove the switching valve assembly, TB 0446, from the pump housing.

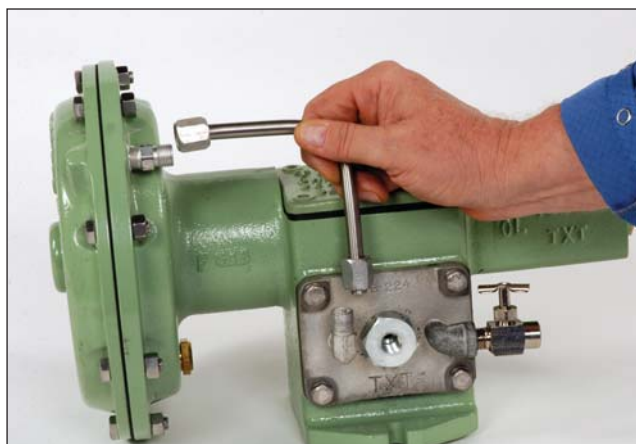

TB 1193 Removal

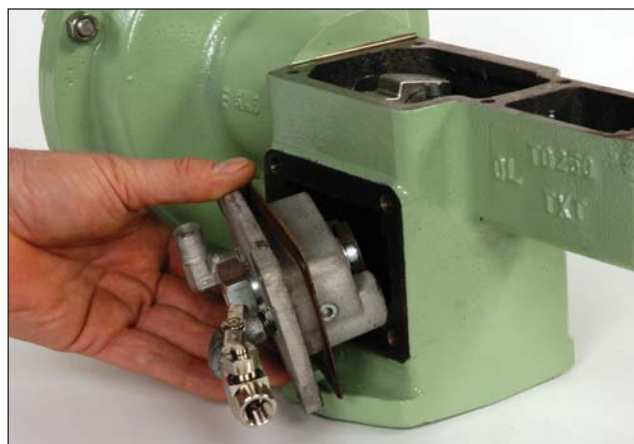

Switching Valve Assembly Removal

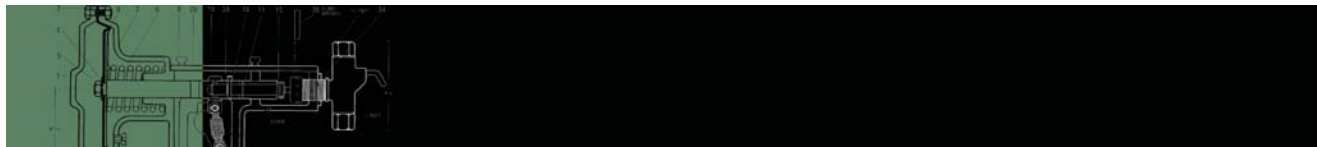

4. Remove the TB 0548 cover.
5. Remove adjusting pin, TA 1828.
6. Remove TC 0252 diaphragm cover.
7. Pull diaphragm TC 2128 and thrust rod TB 0444 out.
8. Remove stirrup assembly TA 6564.

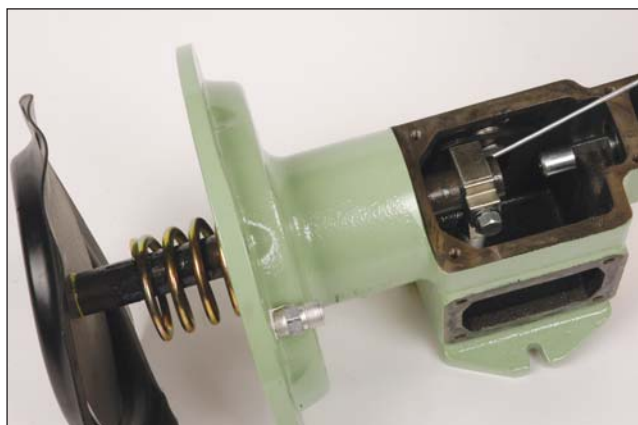

Steps 4 through 8

9. Remove Bumper Plate Assembly, TA 1823, TA 0459, TA 3323, and TA 1827.



Bumper Plate

10. Install microswitch thrust rod collar assembly TA 7090-1. Ensure that the clamping bolt is on the opposite side of the thrust rod from where the microswitch will be installed. Place TA 7090-1 over the area where the stirrup assembly TA 6564 would normally attach to the thrust rod. Do not tighten the clamping bolt at this time.

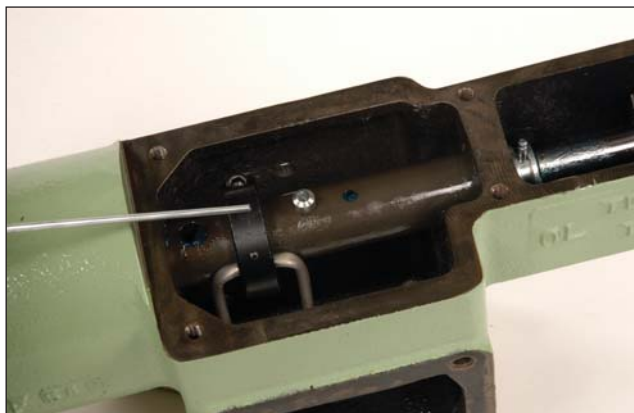

Steps 10 through 12

11. Push the diaphragm TC 2128 back into position and reinstall the TC 0252 diaphragm cover.
12. Reinsert TA 1828 adjusting pin.

13. Install TA 7092 microswitch valve onto the TA 7088 mounting plate with the two P01-025050-0200 HHCS. Ensure the "TXT" tag is facing up.
14. With the microswitch installed in the mounting plate, ensure the lever arm is switched to the left position. Place the gasket, TA 0058 between the mounting plate and the housing, then attach the mounting plate to the pump housing, TD 0531 using the four HHCS, P01-031050-0200, with the four lock washers, P52-031000-0200. Ensure the microswitch valve extended shaft is between the forks on the TA 7090-1 assembly.

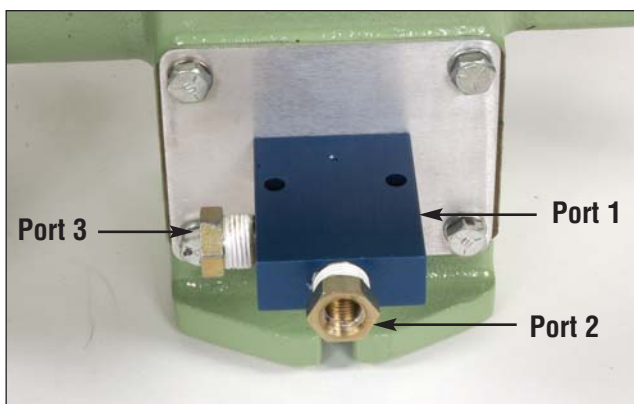

Microswitch Assembly Installed

AIR OR GAS DRIVEN INJECTORSseries **5100**

15. Attach the speed control valve, TA-2489 to the exhaust, Port 3 (left port).

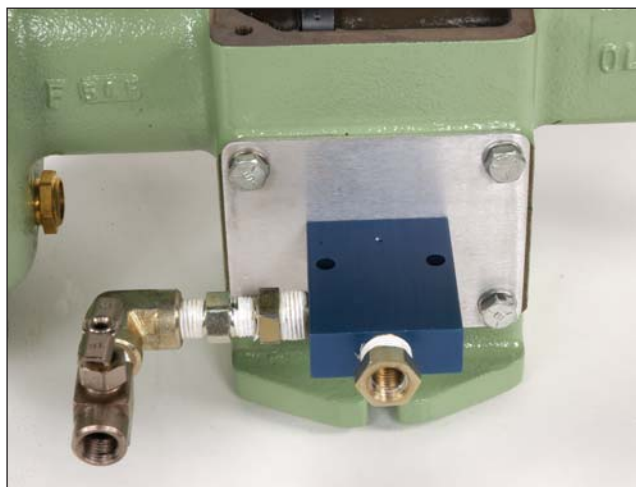
**Speed Control Valve Installation**

16. Attach the 1/4 MNPT X 3/8 tubing 90° elbow, TA 7096, to Port 2 (center port).
17. Assemble the tubing using the ferrule, TA 7097, and flareless nut, TA 7098, then attach the tubing assembly, TA7092, to the elbow and to the pump head.

**Steps 16 through 19**

18. Tighten the clamping bolt on the thrust rod collar assembly.
19. Connect supply gas to Port 1 on the microswitch valve. Stroke the pump several times. You may need to adjust the location of the thrust rod collar to optimize operation of the pump.

20. Control the speed of the pump using the gas supply pressure and the speed control valve to achieve the desired stroke rate.

Min. gas pressure: 18 psi

Max. gas pressure: 35 psi

Microswitch Valve Replacement

- Shutoff gas flow to the pump.
- Disconnect the gas supply pipe from Port 1 on the microswitch valve.
- Disconnect and remove TA 7092 tubing assembly.
- Remove two bushings, TA 7095, from Ports 2 and 3 on the microswitch valve.
- Remove the TB 0548 cover.
- Remove the four P01-031-3900 machine screws and four P52-031000-3900 lock washers. Remove the microswitch valve assembly from the pump housing.
- Remove the old microswitch from the mounting plate and replace with the new microswitch.
- Reinstall the mounting plate with microswitch valve and gasket using the four machine screws and lock washers. Ensure the microswitch valve extended shaft is between the forks of the TA 7090-1 assembly.
- Reinstall the TB 0548 cover.
- Replace the TA 7095 bushings back into ports 2 and 3 as shown.

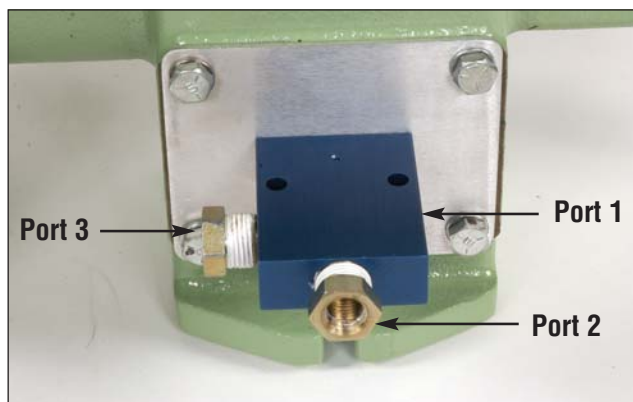

- Reconnect the TA 7092 tubing assembly.
- Reconnect the gas supply line to the microswitch valve.



Dresser Industrial Products Group

16240 Port Northwest Drive
Houston, Texas 77041-2645

Phone: 832-590-2306

Fax: 713.849.2879
www.dresser.com



Dresser, Inc.