



780.897.5869
BURKECALIBRATION.COM

Sur-Flo SVN2000 Compact Insertion Flow Meter

Questions? Call us at 780-897-5869 or email info@burkecalibration.com



SUR-FLO
METERS & CONTROLS LTD.

SVN2000 Flow Meters

Compact Insertion Meter

DESCRIPTION

The SVN2000 Compact Insertion Vortex Flow Meter measures the volumetric or mass flow rate or BTU/energy of steam, gas or liquids over a large flow range. The meter includes a mounting assembly alignment pin to simplify the installation. The meter is designed for specific pipe sizes and includes parts for installation.

The vortex sensing element is CNC machined out of one piece of solid stainless steel and engineered to stand up to abusive environments inside and outside the pipe. The dual ceramic piezoelectric sensors are bonded inside the vortex element, which is press-fit to the stainless steel insertion bar and completely welded together. There are no internal o-rings or seals of any kind and absolutely no leak paths into the sensors or electronics. Our sensors do not touch the process fluid, which gives them an almost unlimited life span.

BENEFITS

- Measure volumetric, mass flow rate or BTU/energy of steam, gas or liquids
- Lower profile insertion meter for pipes 2...24 in.
- Simplify installation with an insertion meter and pipe mounting assembly designed for the specific pipe size
- Reduced noise interference with dual piezoelectric sensors and filtering
- Standard model handles process temperatures up to 400° F (204° C)
- Reduced maintenance due to:
 - ◊ Heavy duty welded stainless steel construction
 - ◊ O-ring-free element
 - ◊ No moving parts
 - ◊ Piezoelectric and temperature sensors never touch process fluid

OPERATION

An everyday example of a vortex shedding phenomenon is a flag waving in the breeze: the flag waves due to the vortices shed by air moving across the flagpole. Within the flow meter, as flowing fluid moves across the tiny strut or "shedder bar", vortices are shed on a smaller scale. The frequency of the vortices shedding is proportional to the fluid velocity.

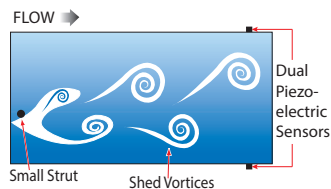

Through the use of an internal RTD, the flow meter software compensates for changes in temperature to achieve an accurate mass flow measurement.

With the addition of a second external RTD, the meter can measure the energy transfer across a heat exchanger.



APPLICATIONS

The unique design of the SVN2000 meter can be used in steam, gas or liquid lines. The same design can measure water as low as 1.32 feet per second and saturated steam in excess of 250 feet per second.

INSTALLATION

The SVN2000 Compact meter includes a mounting assembly with alignment pin and an arrow machined into the mounting assembly that shows the direction of flow.

After depressurizing the pipe and welding the mounting assembly onto a welded outlet, insert the SVN2000 Compact meter into the mounting assembly and align the meter so the pin can be inserted into the mounting assembly. When the pin is inserted, you are ensured that the meter is inserted to the proper depth and is aligned with the flow. The pin also acts as a secondary method to prevent the meter from coming out of the pipe once the pipe is pressurized.

SIZING SOFTWARE

The Vortex Sizing Application software determines the precise scaling factor for your application based on:

- Fluid type
- Min. and max. operating flow rate
- Operating temperature
- Operating pressure

SPECIFICATIONS

	Uncertainty	
	Volumetric Flow	Repeatability
Liquids	±1.0% of reading	±0.25% of reading
Steam	±1.0% of reading	±0.25% of reading
Gas	±1.0% of reading	±0.25% of reading
	Mass or Heat Flow	
	Repeatability	
Liquids	±1.0% of reading	
Steam	±1.0% of reading	
Gas	±1.0% of reading	
Velocity – Liquid	1.32...32 ft/s (0.402...9 m/s)	
Velocity – Gas	cube root (140/p) ft/s... 300 ft/sec (91 m/sec)	
Reynolds Range	10,000...7,000,000 depending on fluid density	
Straight Run Pipe	Upstream 10 diameters; downstream 5 diameters with one 90° elbow before the meter	
Pipe sizes	2...24 in. (50...1200 mm)	
Fluid temperature	-250...400° F (-120...204°C)	
Maximum Pressure	1000 psi (68.9 bar)	
Wetted Materials	Stainless steel 304L	
Connections	1-1/2 in. carbon steel mounting assembly Sealing assembly: Two ethylene propylene O-rings	

Measurement Options	Sensors				
Volumetric flow rate	Dual piezo vortex sensors				
Mass flow rate based on velocity and temperature	Dual piezo vortex sensors RTD embedded in sensor: 100 Ohm, 3 wire				
BTU/Energy	Dual piezo vortex sensors RTD embedded in sensor: 100 Ohm, 3 wire External 100 Ohm RTD input				
Units of measure	Steam	Gases	Liquids	Energy (Any Fluid)	
	Pounds	Pounds	Pounds	BTU	
	Kilograms	Kilograms	Kilograms		
	Tons	Tons	Tons		
	Metric Tons	Metric Tons	Metric Tons		
	Cubic Feet	Cubic Feet	Cubic Feet		
	Cubic Meters	Actual Cubic Feet	Cubic Meters		
	Gallons	Natural Cubic Meters	Gallons		
	Liters	Actual Cubic Meters	Liters		
		U.S. Gallons			
	Natural Liters				
	Actual Liters				
	Units of measure are used for flow rate, mass flow rate, heat/energy flow rate; volume total, mass total, heat/energy total				
Measurement interval	Second, minute, hour, day				

Transmitter

Display	2x16 characters reflective display Rotatable display Flow rate: 6 digits with decimal Totalizer
Keypad	4 membrane buttons
Power	14...36 V DC; loop powered with 4...20 mA option
Operating Temperature	32...140° F (0... 60° C) 5...95% relative humidity non-condensing
Output	One 4...20 mA, 10...36V max load, 24-bit resolution Adjust the 4 mA and 20 mA signal from the keypad and zero out any anomalies found between the meter and the monitoring device
Digital Output	One min. input resistance 1000 Ohm Max output frequency = 12.5 Hz Opto isolator 5...24V DC
Communication	EIA-485 with Modbus RTU (9600, 14400, 19200 baud) or BACnet MS/TP (9600, 19200, 38400, 76800 baud)
Enclosure	General purpose
Mounting	Integral meter or remote mount; Up to 30 ft (10 m) from pipe
Cable	Cable jacket material: polyurethane (gray) Operating temperature -13...185° F (-25...85° C)

FLOW RATE TABLES

Saturated Steam Minimum...Maximum Flow Rates in lb/hr

Pipe Line Size in.	Pressure (psig); Density (lb/ft ³)						
	5 psig 0.0486 lb/ft ³	50 psig 0.1503 lb/ft ³	100 psig 0.2577 lb/ft ³	150 psig 0.3614 lb/ft ³	200 psig 0.4688 lb/ft ³	300 psig 0.6481 lb/ft ³	400 psig 0.8613 lb/ft ³
2	58.38...1019	124.0...3152	177.7...5404	222.7...7580	264.9...9832	328.7...13592	397.4...18064
3	128.6...2244	273.2...6945	391.4...11905	490.5...16698	583.5...21662	724.2...29944	875.5...39797
4	221.5...3865	470.5...11959	674.0...20501	844.7...28755	1005...37302	1247...51565	1508...68531
6	502.6...8771	1068...27140	1530...46525	1917...65256	2280...74653	2830...117021	3421...155525
8	870.4...15188	1849...46997	2649...80564	3319...112999	3949...146586	4900...202637	5924...269310
10	1372...23939	2914...74078	4175...126988	5232...178113	6224...231055	7724...319403	9338...424496
12	1947...33981	4137...105152	5927...180256	7427...252827	8835...327976	10964...453385	13255...602561
14	2354...41075	5000...127102	7164...217884	8977...305604	10679...396440	13253...548028	16022...728344
16	3075...53649	6531...166010	9357...284583	11725...399157	13948...517799	17310...715791	20927...951306
18	3892...67907	8267...210132	11843...360218	14842...505242	17655...655418	21911...906031	26489...1204139
20	4836...84381	10273...261109	14717...447606	18442...627814	21938...814421	27227...1125833	32915...1496262
22	6170...107670	13108...333173	18778...571142	23532...801085	27993...1039195	34741...1436554	41999...1909218
24	6994...122044	14858...377651	21285...647389	26674...908029	31730...1177925	39379...1628331	47606...2164096

Saturated Steam Minimum...Maximum Flow Rates in kg/hr

Pipe Line Size mm	Pressure (bar); Density (kg/m ³)						
	0.4 bar 0.7779 kg/m ³	3.4 bar 2.372 kg/m ³	6.9 bar 4.127 kg/m ³	11 bar 6.125 kg/m ³	13.8 bar 7.508 kg/m ³	20.7 bar 10.38 kg/m ³	27 bar 13.79 kg/m ³
50	26.48...462.0	55.70...1409	80.58...2451	104.9...3637	120.1...4459	149.1...6164	180...8192
75	58.33...1018	122.7...3104	177.5...5399	231.0...8013	264.6...9824	328.4...13580	397.0...18048
100	100.4...1753	211.3...5345	305.7...9297	397.8...13799	455.7...16917	565.5...23385	683.7...31080
150	228.0...3978	479.5...12130	693.7...21100	902.7...31315	1034...38391	1283...53071	1552...70533
200	394.7...6888	830.4...21004	1201...36537	1563...54226	1791...66479	2222...91899	2687...122136
250	622.2...10857	1309...33108	1894...57591	2464...85472	2823...104787	3503...144854	4235...192515
300	883.2...15411	1858...46996	2688...81749	3498...121326	4007...148742	4973...205617	6011...273270
350	1068...18628	2246...56806	3249...98813	4228...146652	4843...179791	6011...248539	7266...330315
400	1394...24330	2933...74195	4243...129063	5522...191546	6326...234830	7851...324622	9491...431431
450	1765...30797	3713...93914	5371...163364	6989...242454	8007...297242	9937...410898	12013...546095
500	2193...38268	4614...116698	6674...202996	8685...301273	9949...369352	12348...510582	14927...678577
550	2798...48830	5887...148906	8516...259021	11082...384421	12695...471290	15756...651498	19047...865859
600	3172...55349	6673...168784	9653...293600	12561...435741	14390...534207	17859...738472	21590...981449

Air Minimum...Maximum Flow Rates in ft³/min (SCFM *)

Pipe Line Size in.	Pressure (psig); Density (lb/ft ³)								
	0 psig 0.075 lb/ft ³	50 psig 0.3312 lb/ft ³	100 psig 0.5871 lb/ft ³	150 psig 0.843 lb/ft ³	200 psig 1.0998 lb/ft ³	300 psig 1.611 lb/ft ³	400 psig 2.123 lb/ft ³	500 psig 2.635 lb/ft ³	1000 psig 5.194 lb/ft ³
2	17.05...344.2	45.82...1515	67.13...2686	85.45...3857	102.0...5028	131.6...7370	158.2...9711	182.7...12053	287.4...23762
3	37.57...758.4	100.9...3338	147.9...5918	188.3...8497	224.7...11077	290.0...16236	348.5...21395	402.6...26554	633.1...52350
4	64.69...1306	173.8...5748	254.7...10190	324.2...14632	386.9...19074	499.3...27959	600.2...36843	693.3...45727	1090...90148
6	146.8...2964	394.5...13045	578.0...23126	735.7...33207	878.0...43288	1133...63450	1362...83612	1573...103774	2474...204583
8	254.2...5132	683.1...22589	1001...40045	1274...57501	1520...74958	1962...109871	2359...144784	2724...179696	4284...354261
10	400.7...8090	1077...35605	1578...63120	2008...90636	2397...118151	3093...173182	3718...228213	4294...283244	6753...558398
12	568.8...11483	1528...50540	2239...89598	2850...128655	3402...167713	4390...245828	5277...323942	6095...402057	9585...792632
14	687.6...13880	1848...61090	2707...108301	3446...155512	4112...202722	5307...297143	6379...391565	7368...485986	11586...958092
16	898.1...18129	2413...79792	3535...141454	4500...203117	5371...264780	6931...388106	8332...511431	9623...634757	15133...1251385
18	1137...22947	3054...100998	4475...179050	5696...257101	6798...335152	8773...491254	10546...647357	12181...803459	19155...1583972
20	1413...25814	395...125500	5561...222487	7078...319473	8447...416459	10902...610432	13104...804405	15135...998378	23802...1968241
22	1802...36384	4843...160137	7095...283891	9032...407645	10779...531399	13910...778907	16721...1026414	19313...1273922	30371...2511460
24	2043...41241	5489...181516	8042...321790	10237...462065	12218...602340	15767...882889	18953...1163439	21891...1443988	34426...2846736

* Standard conditions of 68° F (20° C) in schedule 40 pipe

Air Minimum...Maximum Flow Rates in m³/min (SCMM *)

Pipe Line Size mm	Pressure (bar); Density (kg/m ³)								
	0 bar 1.205 kg/m ³	3.4 bar 5.248 kg/m ³	6.9 bar 9.409 kg/m ³	11 bar 14.28 kg/m ³	13.8 bar 17.61 kg/m ³	20.7 bar 25.82 kg/m ³	27.6 bar 34.02 kg/m ³	34.5 bar 42.22 kg/m ³	69 bar 83.24 kg/m ³
50	0.4829...9.748	1.288...4245	1.902...76.11	2.512...115.5	2.889...142.5	3.927...208.8	4.482...275.2	5.177...341.6	8.141...673.4
75	1.064...21.48	2.838...93.52	4.190...167.7	5.535...254.6	6.365...313.9	8.215...460.1	9.875...606.3	11.41...752.5	17.94...1484
100	1.832...36.98	4.888...161.0	7.215...288.7	9.531...438.3	10.96...540.5	14.15...792.3	17.00...1044	19.64...1296	30.89...2555
150	4.157...83.93	11.09...365.5	16.37...655.3	21.63...994.8	24.88...1227	32.10...1798	38.59...2369	44.57...2941	70.09...5798
200	7.199...145.3	19.21...632.8	28.35...1135	37.46...1723	43.07...2124	55.59...3113	66.82...4103	77.18...5092	121.4...10039
250	11.35...229.1	30.27...997.5	44.69...1789	59.04...2715	67.90...3348	87.62...4908	105.3...6467	121.7...8027	191.3...15824
300	16.11...325.2	42.97...1416	63.44...2539	83.81...3854	96.38...4752	124.4...6966	149.5...9180	172.7...11393	271.6...22462
350	19.47...393.0	51.95...1712	76.68...3069	101.3...4659	116.5...5745	150.3...8420	180.7...11096	208.7...13772	328.3...27151
400	25.43...513.4	67.85...2235	100.2...4008	132.3...6085	152.2...7503	196.4...10998	236.0...14493	272.6...17988	428.7...35462
450	32.19...649.8	85.88...2830	126.8...5073	167.5...7702	192.6...9497	248.5...13921	298.8...18345	345.1...22768	542.7...44887
500	40.00...807.4	106.7...3516	157.5...6304	208.1...9571	239.3...11801	308.8...17298	371.3...22795	428.8...28292	674.3...55776
550	51.04...1030	136.2...4486	201.0...8044	265.5...12212	305.4...15058	394.1...22072	473.7...29086	547.1...36100	860.5...71170
600	57.85...1168	154.3...5085	227.8...9118	301.0...13842	346.1...17068	446.7...25019	537.0...32969	620.2...40919	975.3...80671

* Standard conditions of 68° F (20° C) in schedule 40 pipe

Liquid Minimum...Maximum Flow Rates in US Gal/min *

Pipe Line Size in.	Density 62.3 lb/ft ³
2	13.80...313.7 gpm
3	30.41...691.2 gpm
4	52.37...1190 gpm
6	118.9...2701 gpm
8	205.8...4678 gpm
10	324.4...7373 gpm
12	460.5...10466 gpm
14	556.6...12650 gpm
16	727.0...16523 gpm
18	920.2...20914 gpm
20	1143...25988 gpm
22	1459...33160 gpm
24	1654...37587 gpm

* Standard conditions of 70° F (21.11° C)

Liquid Minimum...Maximum Flow Rates in Liter/min *

Pipe Line Size in.	Density 997.77 kg/m ³
50	52.26...1188 lpm
75	115.1...2616 lpm
100	198.2...4506 lpm
150	449.9...10225 lpm
200	779.1...17706 lpm
250	1228...27909 lpm
300	1743...39616 lpm
350	2107...47885 lpm
400	2752...62544 lpm
450	3483...79167 lpm
500	4328...98373 lpm
550	5523...125523 lpm
600	6260...142280 lpm

* Standard conditions of 70° F (21.11° C)

DIMENSIONS

EVN2000 Compact Insertion Meter with 1-1/2 in. NPT Connection

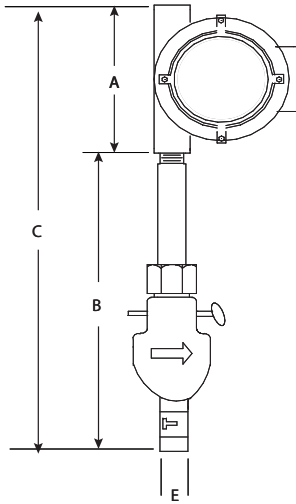

Figure 1: Compact meter

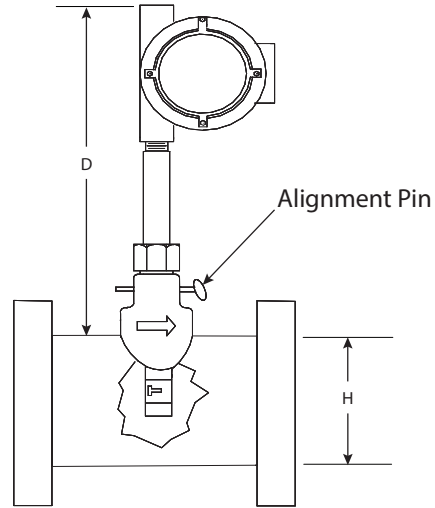

Figure 2: Compact meter inserted into pipe

H		A		B		C		D		E	
in.	mm	in.	mm	in.	mm	in.	mm	in.	mm	in.	mm
2, 3	51, 76	5	127	11	279	16	406	15, 14.5	381, 368	1.25	32
4, 5	102, 127	5	127	12	305	17	432	15, 14.5	381, 368	1.25	32
6	152	5	127	13	330	18	457	15	381	1.25	32
8	203	5	127	14	356	19	483	15	381	1.25	32
10	254	5	127	15	381	20	508	15	381	1.25	32
12	305	5	127	16	406	21	533	15	381	1.25	32
14	356	5	127	17	432	22	559	15	381	1.25	32
16	406	5	127	18	457	23	584	15	381	1.25	32
18	457	5	127	19	483	24	610	15	381	1.25	32
20	508	5	127	20	508	25	635	15	381	1.25	32
22	559	5	127	21	533	26	660	15	381	1.25	32
24	610	5	127	22	559	27	686	15	381	1.25	32

Power Plug

The multi-pole connector virtually eliminates wiring errors in the field. Simply plug the connector into the top of the enclosure and screw it down. This design saves time and money because the electronics package never comes out of the enclosure. No internal wiring is required and no connecting of hard-to-reach terminal blocks. This design also allows for a conduit connection to be attached over the power plug.

Simply plug and play!



Optional External RTD for BTU/Energy Measurement

An insertion RTD (part number SVNA-RTD) is used in conjunction with an RTD internal to the probe to measure the temperature difference across a heat exchanger. The energy transfer can be calculated by multiplying the temperature difference with the mass flow rate.

